

Turing Machines

Part One

What problems can we solve with a computer?

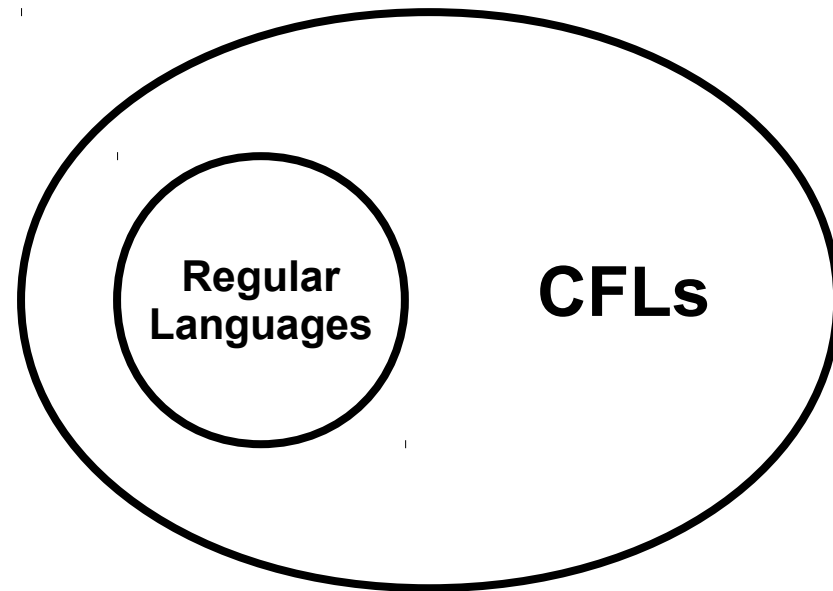

**Today:
What's out
here?**

What Turing Discovered

The Problem

- Finite automata accept precisely the regular languages.
- We may need unbounded memory to recognize context-free languages.
 - e.g. $\{ a^n b^n \mid n \in \mathbb{N} \}$ requires unbounded counting.
- How do we model a computing device that has unbounded memory?

Key Idea: Even if you need huge (unlimited) amounts of scratch space to perform a calculation, at each point in the calculation you only need access to a small amount of that scratch space.

$$\begin{array}{r} 27182818284590 \\ + 31415926535897 \\ \hline \end{array}$$

$$\begin{array}{r} 27182818284590 \\ + 31415926535897 \\ \hline 7 \end{array}$$

$$\begin{array}{r} 271828182845^190 \\ + 31415926535897 \\ \hline 271828182845^187 \end{array}$$

$$\begin{array}{r} 27182818284^1590 \\ + 31415926535^1897 \\ \hline 27182818284590 \\ 31415926535897 \\ \hline 58598745140897 \end{array}$$

$$\begin{array}{r} 2718281828 \\ + 3141592653 \\ \hline 2718281828 \\ + 3141592653 \\ \hline 5859874587 \end{array}$$

$$\begin{array}{r} 271828182 \mathbf{8} 4590 \\ + 314159265 \mathbf{3} 5897 \\ \hline 271828182 \mathbf{8} 4597 \\ \mathbf{8} 4597 \end{array}$$

$$\begin{array}{r} 27182818 \mathbf{2} 84590 \\ + 31415926 \mathbf{5} 35897 \\ \hline 8 \mathbf{2} 0487 \end{array}$$

$$\begin{array}{r} 27182818284590 \\ + 31415926535897 \\ \hline 27182818284590 \\ + 31415926535897 \\ \hline 58598744825487 \end{array}$$

$$\begin{array}{r} 271828\mathbf{1}8284590 \\ + 314159\mathbf{2}6535897 \\ \hline 271828\mathbf{4}4820487 \end{array}$$

$$\begin{array}{r} 27182\mathbf{8}18284590 \\ + 31415\mathbf{9}26535897 \\ \hline 74482\mathbf{0}487 \end{array}$$

$$\begin{array}{r} 2718 \mathbf{2}818284590 \\ + 3141 \mathbf{5}926535897 \\ \hline \mathbf{8}744820487 \end{array}$$

$$\begin{array}{r} 2718 \\ + 3141 \\ \hline 98744820487 \end{array}$$

Carry digits: 1 1 1 1 1 1

$$\begin{array}{r} 27\mathbf{1}828\mathbf{1}8284590 \\ + 31\mathbf{4}15926535897 \\ \hline \mathbf{5}98744820487 \end{array}$$

$$\begin{array}{r} 27182818284590 \\ + 31415926535897 \\ \hline 8598744820487 \end{array}$$

Carry digits: 1 1 1 1 1 1

$$\begin{array}{r} 27182818284590 \\ + 31415926535897 \\ \hline 58598744820487 \end{array}$$

Carry digits: 1 1 1 1 1 1

$$\begin{array}{r} 27182818284590 \\ + 31415926535897 \\ \hline 58598744820487 \end{array}$$

Turing Machines

- To provide his machines extra memory, Turing gave his machines access to an *infinite tape* subdivided into a number of *tape cells*.
- A Turing machine can only see one tape cell at a time, the one pointed at by the *tape head*.
- The Turing machine can
 - read the cell under the tape head,
 - (possibly) change which symbol was written under the tape head, and
 - move its tape head to the left or to the right.

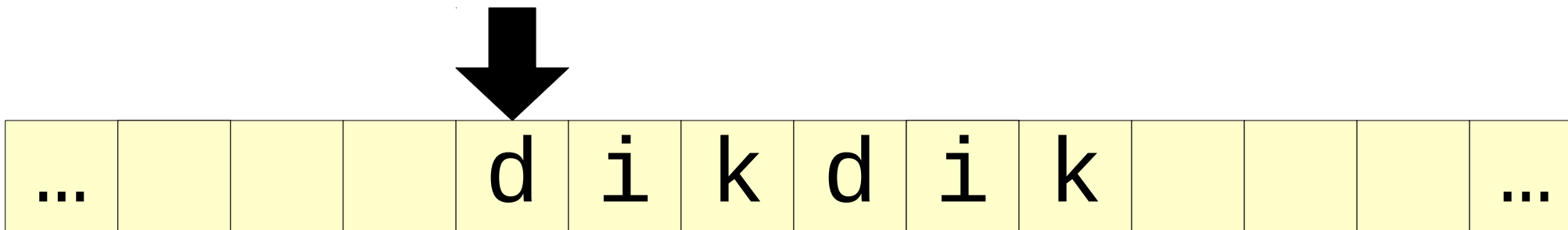

Turing Machines

- To provide his machines extra memory, Turing gave his machines access to an *infinite tape* subdivided into a number of *tape cells*.
- A Turing machine can only see one tape cell at a time, the one pointed at by the *tape head*.
- The Turing machine can
 - read the cell under the tape head,
 - (possibly) change which symbol was written under the tape head, and
 - move its tape head to the left or to the right.

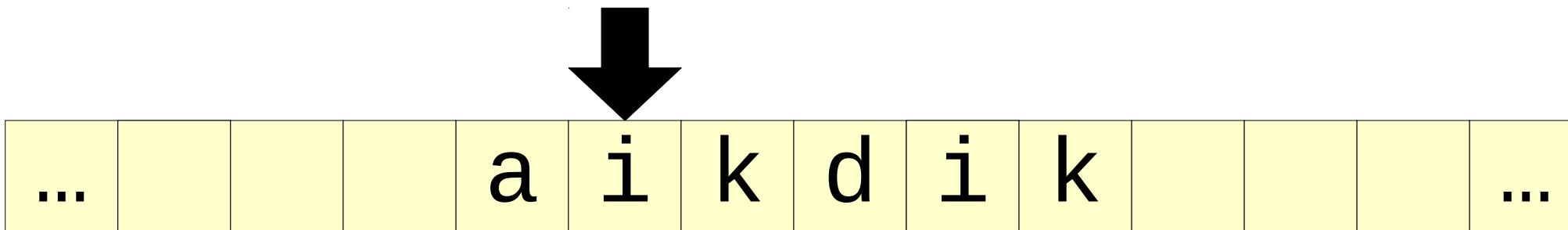

Turing Machines

- To provide his machines extra memory, Turing gave his machines access to an *infinite tape* subdivided into a number of *tape cells*.
- A Turing machine can only see one tape cell at a time, the one pointed at by the *tape head*.
- The Turing machine can
 - read the cell under the tape head,
 - (possibly) change which symbol was written under the tape head, and
 - move its tape head to the left or to the right.

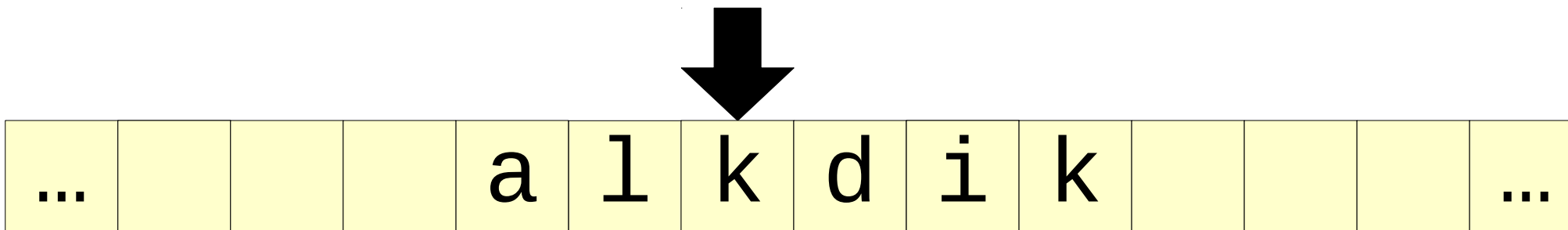

Turing Machines

- To provide his machines extra memory, Turing gave his machines access to an *infinite tape* subdivided into a number of *tape cells*.
- A Turing machine can only see one tape cell at a time, the one pointed at by the *tape head*.
- The Turing machine can
 - read the cell under the tape head,
 - (possibly) change which symbol was written under the tape head, and
 - move its tape head to the left or to the right.

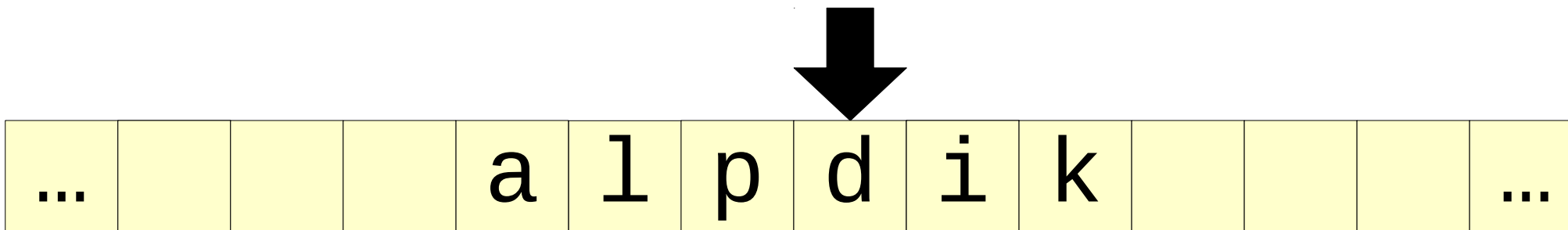

Turing Machines

- To provide his machines extra memory, Turing gave his machines access to an *infinite tape* subdivided into a number of *tape cells*.
- A Turing machine can only see one tape cell at a time, the one pointed at by the *tape head*.
- The Turing machine can
 - read the cell under the tape head,
 - (possibly) change which symbol was written under the tape head, and
 - move its tape head to the left or to the right.

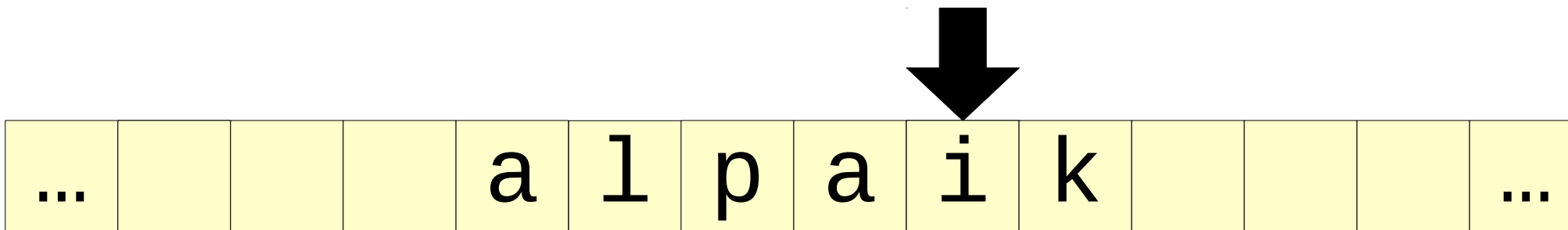

Turing Machines

- To provide his machines extra memory, Turing gave his machines access to an *infinite tape* subdivided into a number of *tape cells*.
- A Turing machine can only see one tape cell at a time, the one pointed at by the *tape head*.
- The Turing machine can
 - read the cell under the tape head,
 - (possibly) change which symbol was written under the tape head, and
 - move its tape head to the left or to the right.

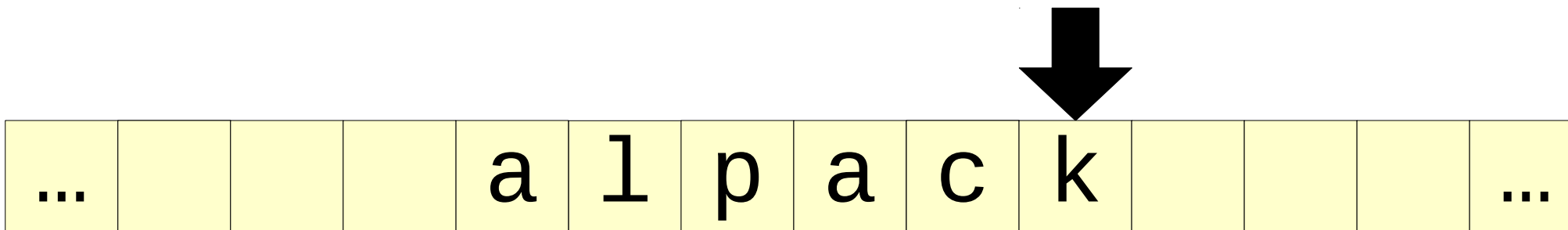

Turing Machines

- To provide his machines extra memory, Turing gave his machines access to an *infinite tape* subdivided into a number of *tape cells*.
- A Turing machine can only see one tape cell at a time, the one pointed at by the *tape head*.
- The Turing machine can
 - read the cell under the tape head,
 - (possibly) change which symbol was written under the tape head, and
 - move its tape head to the left or to the right.

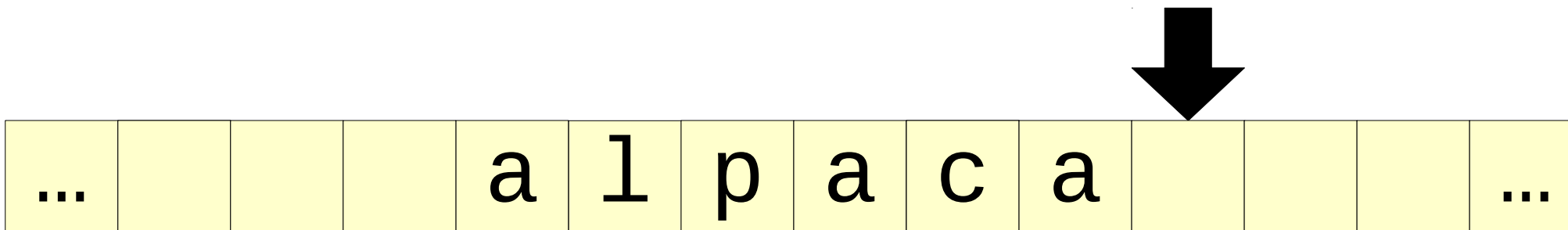

Turing Machines

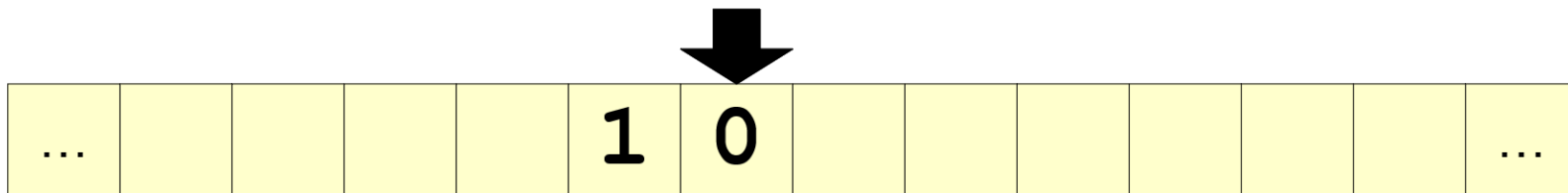
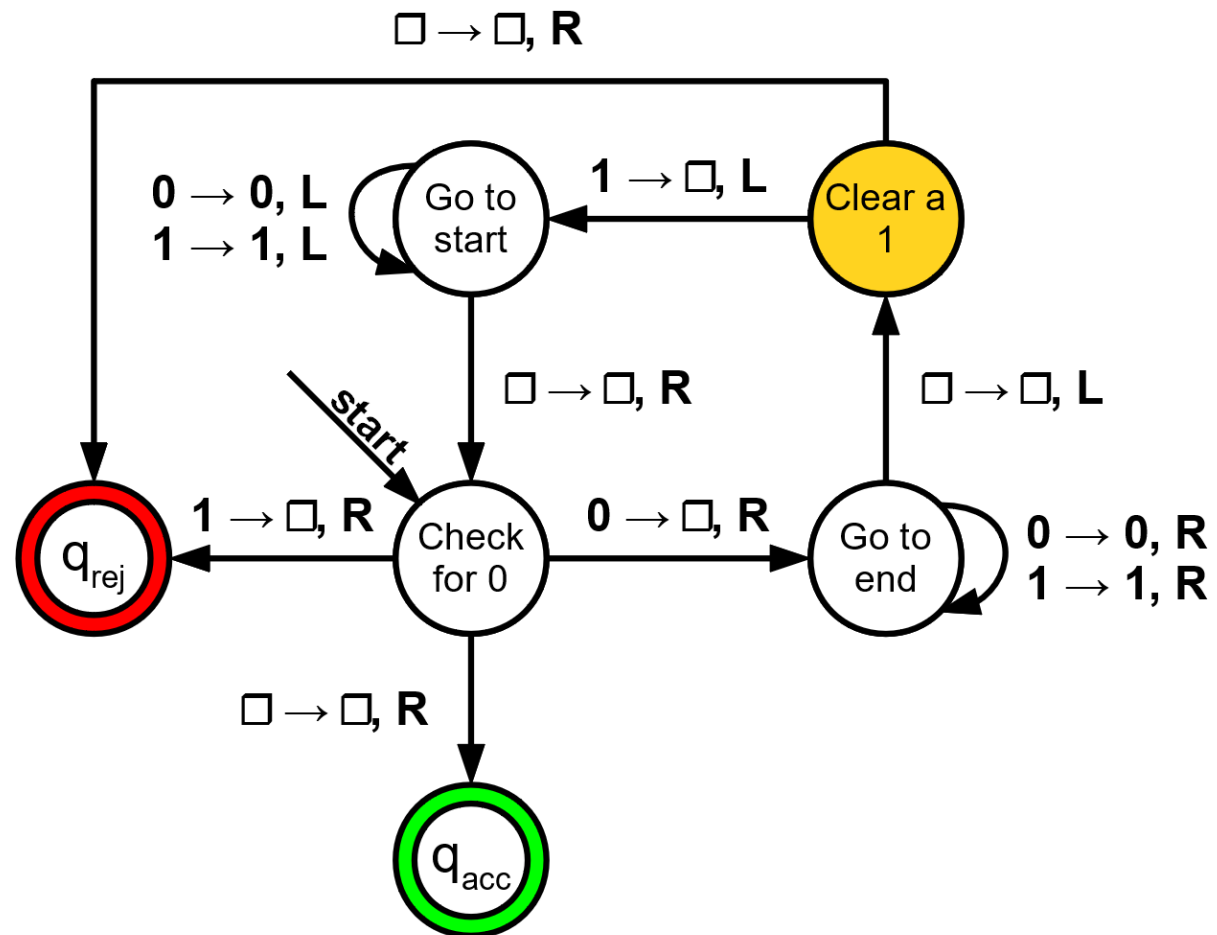

(The Fine Print)

- Over the years, there have been many simplifications and edits to Turing's original automata.
 - In practice, electronic computers are written in terms of individual instructions rather than states and transitions.
 - Turing's original paper deals with computing individual real numbers; we typically want to compute functions of inputs.
- What we're going to present as "Turing machines" in this class differ significantly from Turing's original description, while retaining the core essential ideas.
 - (Our model is closer to Emil Post's *Formulation 1* and Hao Wang's *Basic Machine B*, for those of you who are curious.)
- If you'd like to learn more about Turing's original version of the Turing machine, come chat with me after class!

Turing Machines

- A TM is a series of instructions that control a tape head as it moves across an infinite tape.
- The tape begins with the input string written somewhere, surrounded by infinitely many blank cells.
 - Rule: The input string cannot contain blank cells.
- The tape head begins above the first character of the input. (If the input is ϵ , the tape head points somewhere on a blank tape.)

Start:

If Blank Return True

If 'b' Return False

Write 'x'

Move Right

If Not 'b' Return False

Write 'x'

Move Right

Goto Start

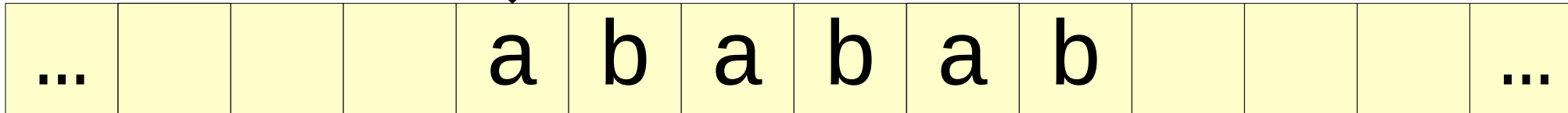
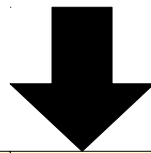

Turing Machines

- We begin at the Start label.
- Labels indicate different sections of code. The name Start is special and means “begin here.”
- Labels have no effect when executed. We just move to the next line.

```
Start:  
  If Blank Return True  
  If 'b' Return False  
  Write 'x'  
  Move Right  
  If Not 'b' Return False  
  Write 'x'  
  Move Right  
  Goto Start
```

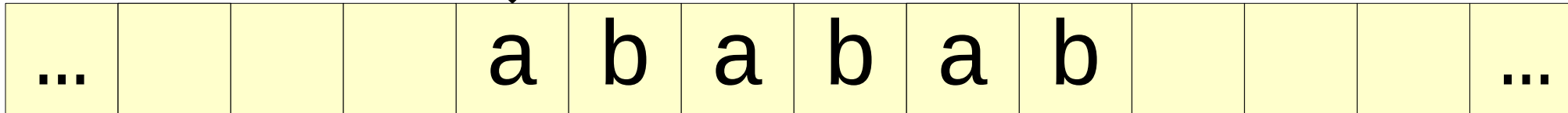
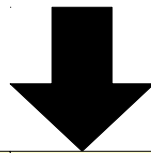

Turing Machines

- We begin at the Start label.
- Labels indicate different sections of code. The name Start is special and means “begin here.”
- Labels have no effect when executed. We just move to the next line.

Start:

```
If Blank Return True  
If 'b' Return False  
Write 'x'  
Move Right  
If Not 'b' Return False  
Write 'x'  
Move Right  
Goto Start
```

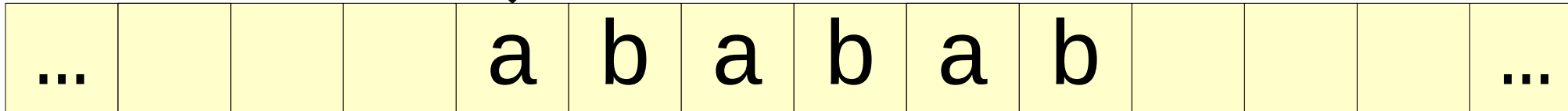
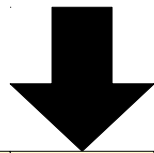

Turing Machines

- We begin at the Start label.
- Labels indicate different sections of code. The name Start is special and means “begin here.”
- Labels have no effect when executed. We just move to the next line.

```
Start:  
If Blank Return True  
If 'b' Return False  
Write 'x'  
Move Right  
If Not 'b' Return False  
Write 'x'  
Move Right  
Goto Start
```

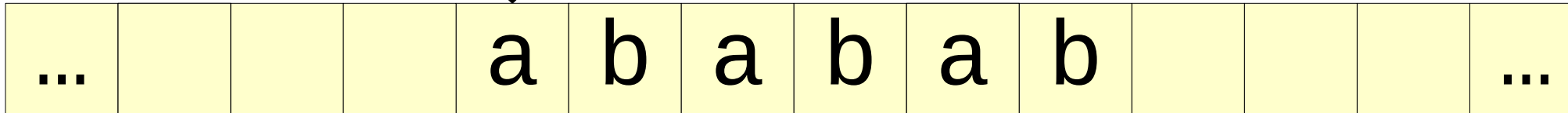
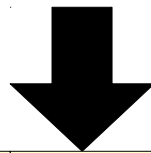

Turing Machines

- A statement of the form
If *symbol* *command*
checks if the character under the tape head is *symbol*.
- If so, it executes *command*.
- If not, nothing happens.

Start:

If Blank Return True

If 'b' Return False

Write 'x'

Move Right

If Not 'b' Return False

Write 'x'

Move Right

Goto Start

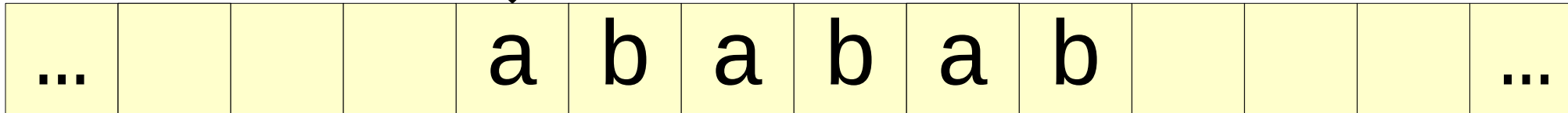
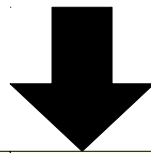

Turing Machines

- A statement of the form
If *symbol* *command*
checks if the character under the tape head is *symbol*.
- If so, it executes *command*.
- If not, nothing happens.

Start:

If Blank Return True

If 'b' Return False

Write 'x'

Move Right

If Not 'b' Return False

Write 'x'

Move Right

Goto Start

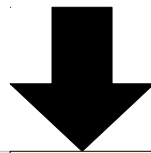

Turing Machines

- A statement of the form
If *symbol* *command*
checks if the character under the tape head is *symbol*.
- If so, it executes *command*.
- If not, nothing happens.

Start:

If Blank Return True

If 'b' Return False

Write 'x'

Move Right

If Not 'b' Return False

Write 'x'

Move Right

Goto Start

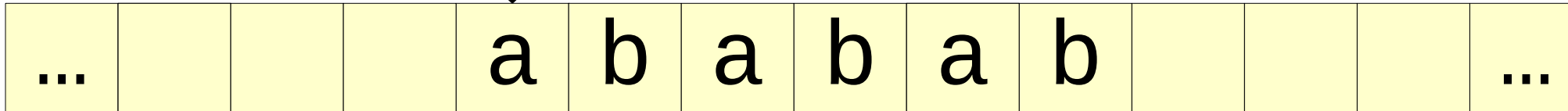
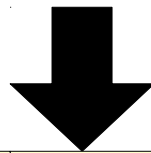

Turing Machines

- A statement of the form
If *symbol* *command*
checks if the character under the tape head is *symbol*.
- If so, it executes *command*.
- If not, nothing happens.

```
Start:  
  If Blank Return True  
  If 'b' Return False  
  Write 'x'  
  Move Right  
  If Not 'b' Return False  
  Write 'x'  
  Move Right  
  Goto Start
```

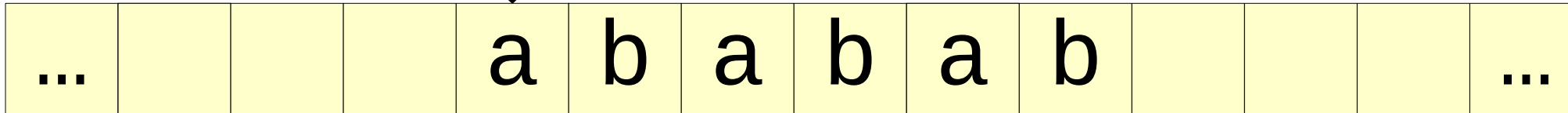
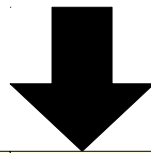

Turing Machines

- A statement of the form
If *symbol* *command*
checks if the character under the tape head is *symbol*.
- If so, it executes *command*.
- If not, nothing happens.

```
Start:  
If Blank Return True  
If 'b' Return False  
Write 'x'  
Move Right  
If Not 'b' Return False  
Write 'x'  
Move Right  
Goto Start
```

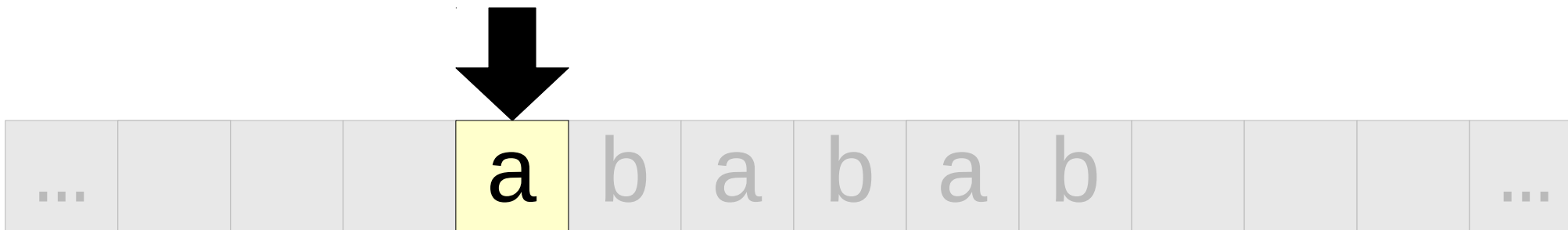

Turing Machines

- A statement of the form
If *symbol* *command*
checks if the character under the tape head is *symbol*.
- If so, it executes *command*.
- If not, nothing happens.

```
Start:  
  If Blank Return True  
  If 'b' Return False  
  Write 'x'  
  Move Right  
  If Not 'b' Return False  
  Write 'x'  
  Move Right  
  Goto Start
```

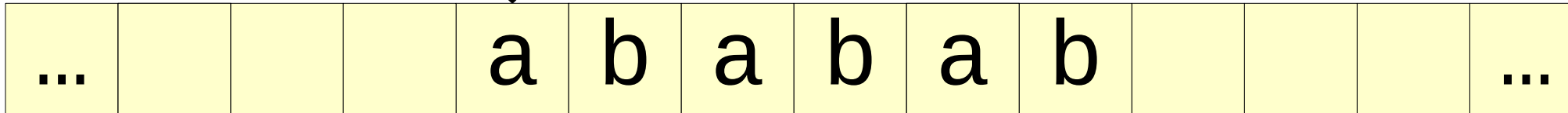
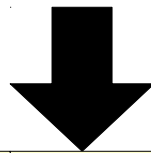

Turing Machines

- A statement of the form
If *symbol* *command*
checks if the character under the tape head is *symbol*.
- If so, it executes *command*.
- If not, nothing happens.

```
Start:  
If Blank Return True  
If 'b' Return False  
Write 'x'  
Move Right  
If Not 'b' Return False  
Write 'x'  
Move Right  
Goto Start
```

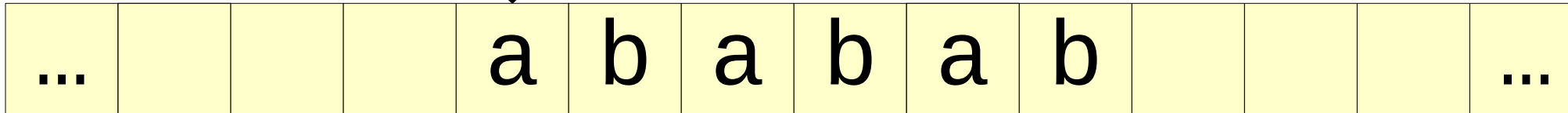
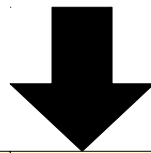

Turing Machines

- The statement

Write *symbol*

writes *symbol* to the cell under the tape head.

- The *symbol* can either be Blank or a character in quotes.

Start:

If Blank Return True

If 'b' Return False

Write 'x'

Move Right

If Not 'b' Return False

Write 'x'

Move Right

Goto Start

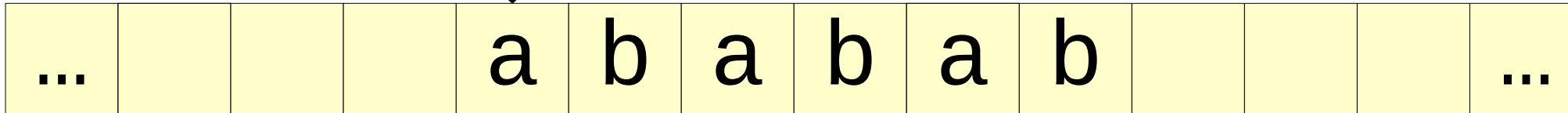
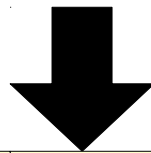

Turing Machines

- The statement

Write *symbol*

writes *symbol* to the cell under the tape head.

- The *symbol* can either be Blank or a character in quotes.

Start:

If Blank Return True

If 'b' Return False

Write 'x'

Move Right

If Not 'b' Return False

Write 'x'

Move Right

Goto Start

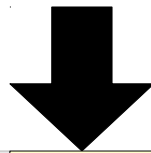

Turing Machines

- The statement

Write *symbol*

writes *symbol* to the cell under the tape head.

- The *symbol* can either be Blank or a character in quotes.

Start:

If Blank Return True

If 'b' Return False

Write 'x'

Move Right

If Not 'b' Return False

Write 'x'

Move Right

Goto Start

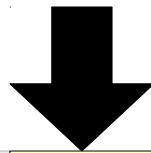

Turing Machines

- The statement **Write *symbol*** writes *symbol* to the cell under the tape head.
- The *symbol* can either be Blank or a character in quotes.

```
Start:  
  If Blank Return True  
  If 'b' Return False  
  Write 'x'  
  Move Right  
  If Not 'b' Return False  
  Write 'x'  
  Move Right  
  Goto Start
```

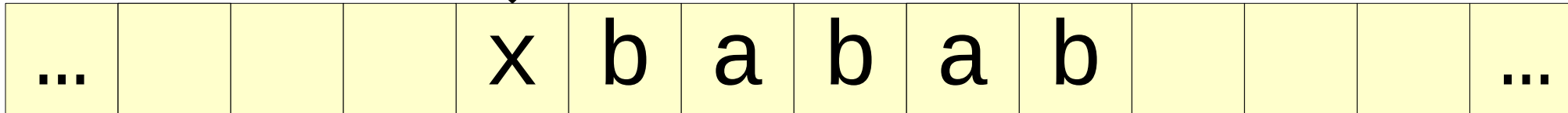
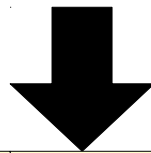

Turing Machines

- The statement **Write *symbol*** writes *symbol* to the cell under the tape head.
- The *symbol* can either be Blank or a character in quotes.

```
Start:  
  If Blank Return True  
  If 'b' Return False  
  Write 'x'  
  Move Right  
  If Not 'b' Return False  
  Write 'x'  
  Move Right  
  Goto Start
```

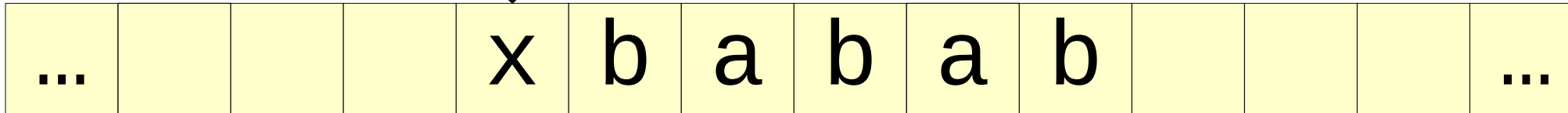
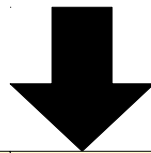

Turing Machines

- The command **Move direction** moves the tape head one step in the indicated direction (either Left or Right).

```
Start:  
  If Blank Return True  
  If 'b' Return False  
  Write 'x'  
  Move Right  
  If Not 'b' Return False  
  Write 'x'  
  Move Right  
  Goto Start
```

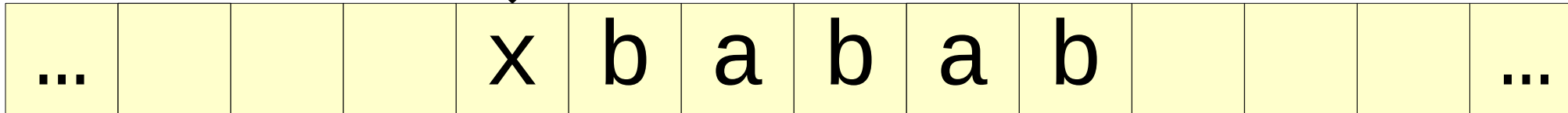
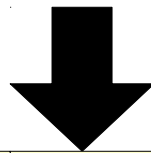

Turing Machines

- The command **Move direction** moves the tape head one step in the indicated direction (either Left or Right).

```
Start:  
  If Blank Return True  
  If 'b' Return False  
  Write 'x'  
  Move Right  
  If Not 'b' Return False  
  Write 'x'  
  Move Right  
  Goto Start
```

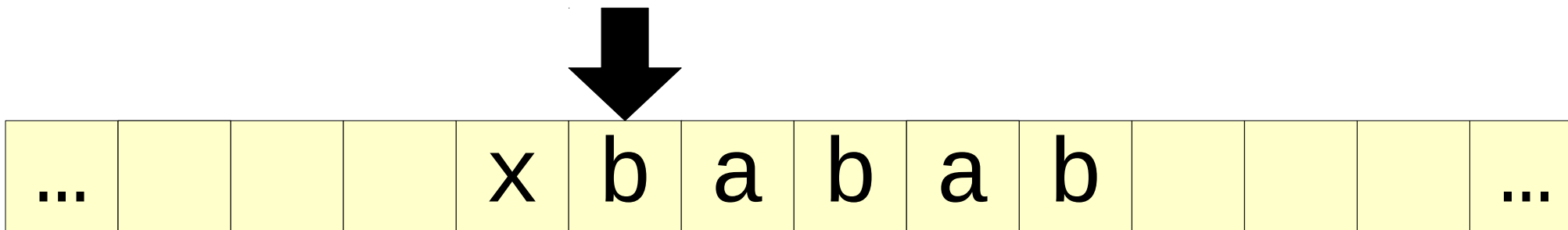

Turing Machines

- The command **Move direction** moves the tape head one step in the indicated direction (either Left or Right).

```
Start:  
If Blank Return True  
If 'b' Return False  
Write 'x'  
Move Right  
If Not 'b' Return False  
Write 'x'  
Move Right  
Goto Start
```

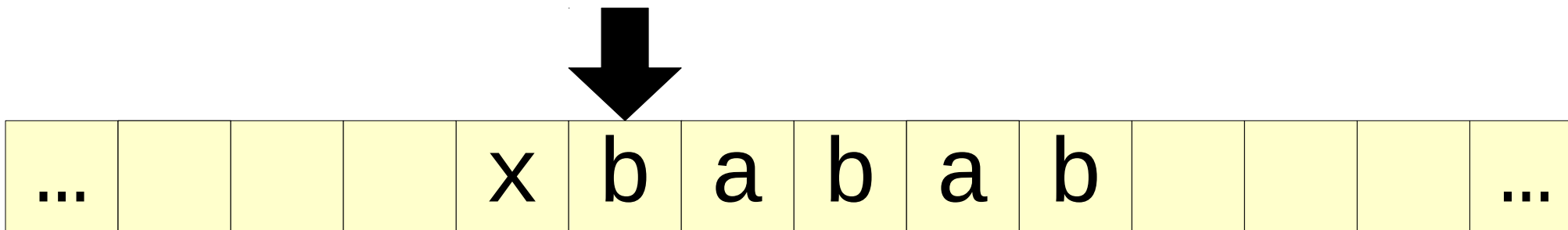

Turing Machines

- A statement of the form

If Not *symbol*
command

sees if the cell under the
tape head holds *symbol*.

- If so, nothing happens.
- If not, it executes
command.

Start:

If Blank Return True

If 'b' Return False

Write 'x'

Move Right

If Not 'b' Return False

Write 'x'

Move Right

Goto Start

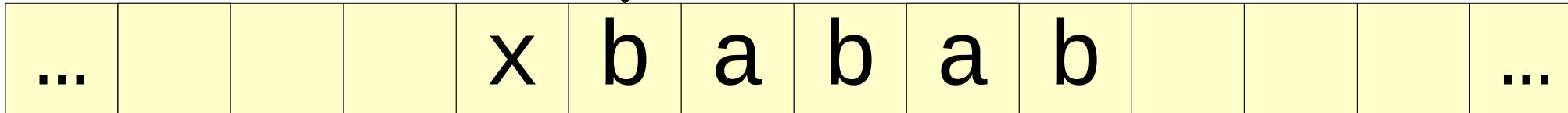
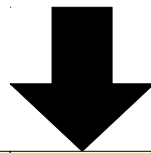

Turing Machines

- A statement of the form

If Not *symbol*
command

sees if the cell under the
tape head holds *symbol*.

- If so, nothing happens.
- If not, it executes
command.

Start:

If Blank Return True

If 'b' Return False

Write 'x'

Move Right

If Not 'b' Return False

Write 'x'

Move Right

Goto Start

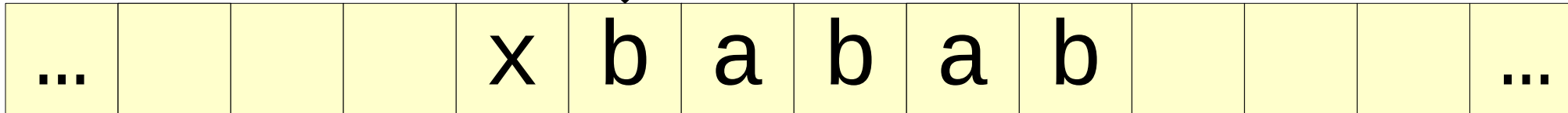
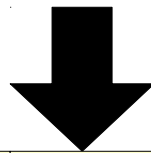

Turing Machines

- A statement of the form

If Not *symbol*
command

sees if the cell under the
tape head holds *symbol*.

- If so, nothing happens.
- If not, it executes
command.

Start:

If Blank Return True

If 'b' Return False

Write 'x'

Move Right

If Not 'b' Return False

Write 'x'

Move Right

Goto Start

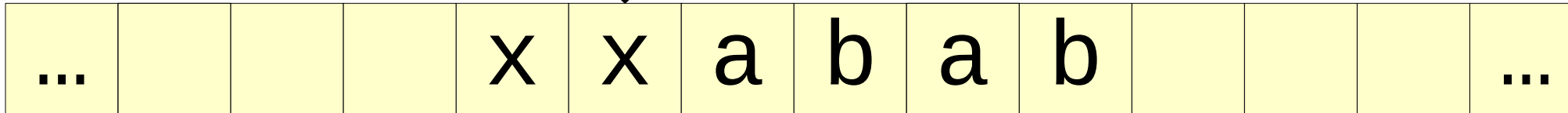
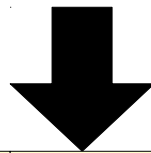

Turing Machines

- A statement of the form

If Not *symbol*
command

sees if the cell under the
tape head holds *symbol*.

- If so, nothing happens.
- If not, it executes
command.

Start:

If Blank Return True

If 'b' Return False

Write 'x'

Move Right

If Not 'b' Return False

Write 'x'

Move Right

Goto Start

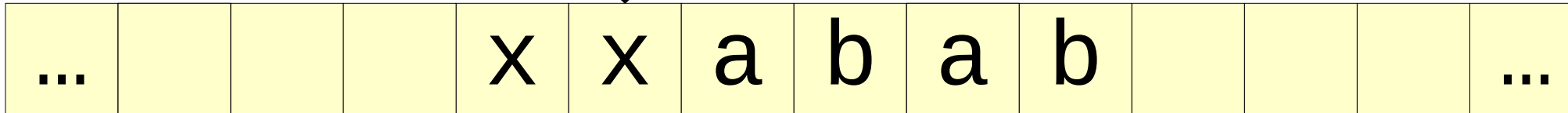
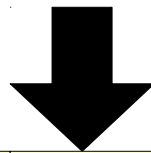

Turing Machines

- A statement of the form

If Not *symbol*
command

sees if the cell under the
tape head holds *symbol*.

- If so, nothing happens.
- If not, it executes
command.

Start:

If Blank Return True

If 'b' Return False

Write 'x'

Move Right

If Not 'b' Return False

Write 'x'

Move Right

Goto Start

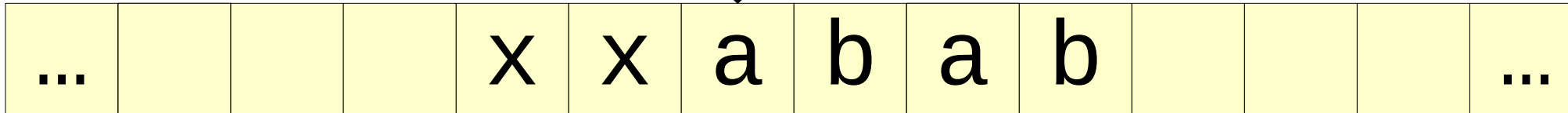
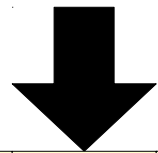

Turing Machines

- A statement of the form

If Not *symbol*
command

sees if the cell under the
tape head holds *symbol*.

- If so, nothing happens.
- If not, it executes
command.

Start:

If Blank Return True

If 'b' Return False

Write 'x'

Move Right

If Not 'b' Return False

Write 'x'

Move Right

Goto Start

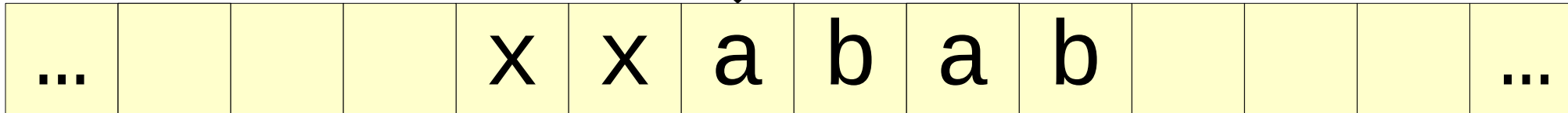
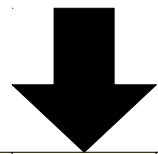

Turing Machines

- The command

Goto *label*

jumps to the indicated label.

- This program just has a Start label, but most interesting programs have other labels beyond this.

Start:

If Blank Return True

If 'b' Return False

Write 'x'

Move Right

If Not 'b' Return False

Write 'x'

Move Right

Goto Start

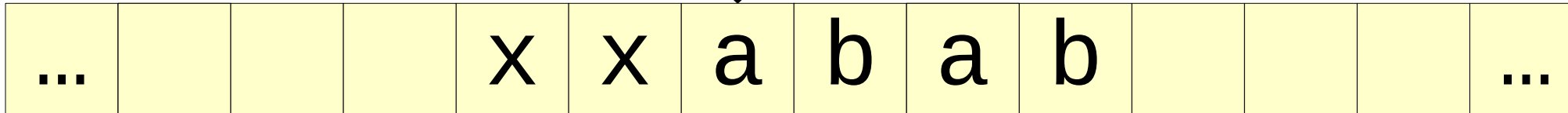
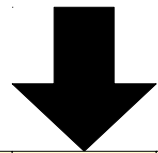

Turing Machines

- The command

Goto *label*

jumps to the indicated label.

- This program just has a Start label, but most interesting programs have other labels beyond this.

Start:

If Blank Return True

If 'b' Return False

Write 'x'

Move Right

If Not 'b' Return False

Write 'x'

Move Right

Goto Start

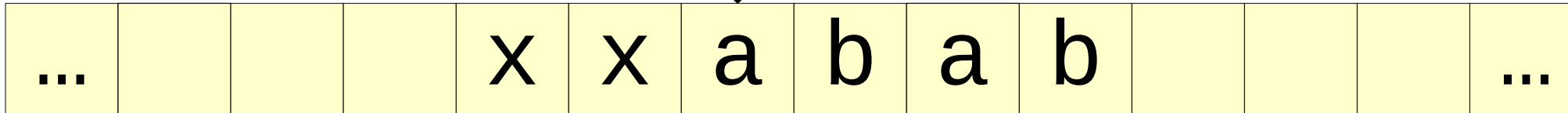
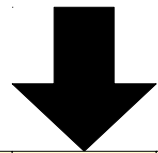

Turing Machines

- A TM stops when executing the

Return *result*

command.

- Here, *result* can be either True or False.
- (If we “fall off” the bottom of the program, the TM acts as though it executes the Return False command.)

Start:

If Blank Return True

If 'b' Return False

Write 'x'

Move Right

If Not 'b' Return False

Write 'x'

Move Right

Goto Start

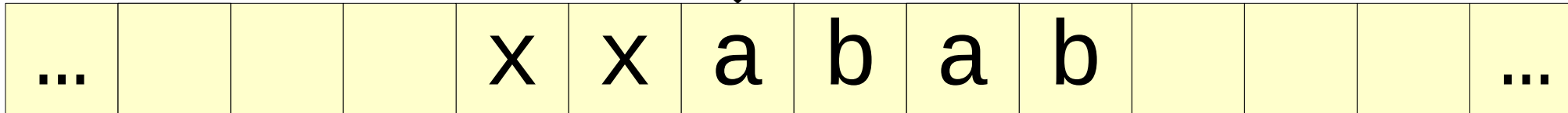
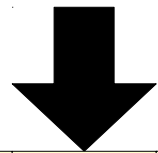

Turing Machines

- A TM stops when executing the

Return *result*

command.

- Here, *result* can be either True or False.
- (If we “fall off” the bottom of the program, the TM acts as though it executes the Return False command.)

Start:

If Blank Return True

If 'b' Return False

Write 'x'

Move Right

If Not 'b' Return False

Write 'x'

Move Right

Goto Start

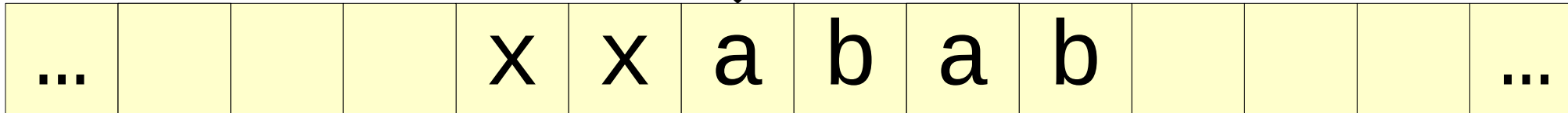
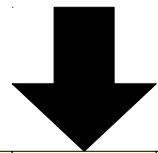

Turing Machines

- A TM stops when executing the

Return *result*

command.

- Here, *result* can be either True or False.
- (If we “fall off” the bottom of the program, the TM acts as though it executes the Return False command.)

Start:

If Blank Return True

If 'b' Return False

Write 'x'

Move Right

If Not 'b' Return False

Write 'x'

Move Right

Goto Start

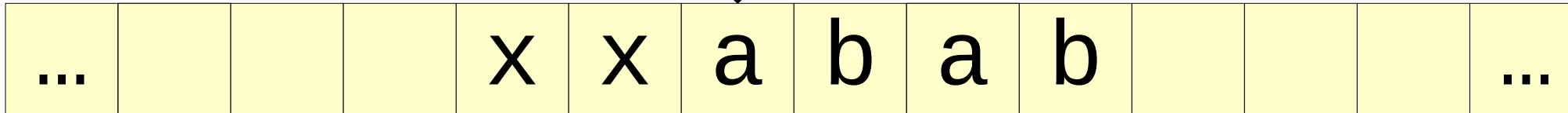
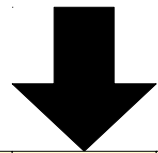

Turing Machines

- A TM stops when executing the

Return *result*

command.

- Here, *result* can be either True or False.
- (If we “fall off” the bottom of the program, the TM acts as though it executes the Return False command.)

Start:

If Blank Return True

If 'b' Return False

Write 'x'

Move Right

If Not 'b' Return False

Write 'x'

Move Right

Goto Start

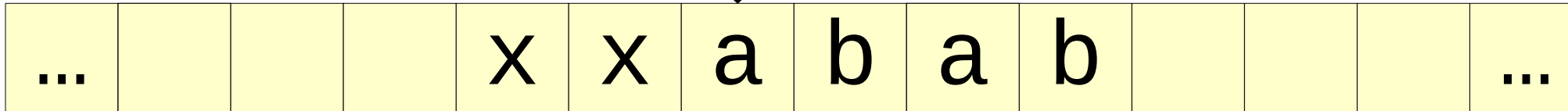
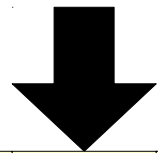

Turing Machines

- A TM stops when executing the

Return *result*

command.

- Here, *result* can be either True or False.
- (If we “fall off” the bottom of the program, the TM acts as though it executes the Return False command.)

Start:

If Blank Return True

If 'b' Return False

Write 'x'

Move Right

If Not 'b' Return False

Write 'x'

Move Right

Goto Start

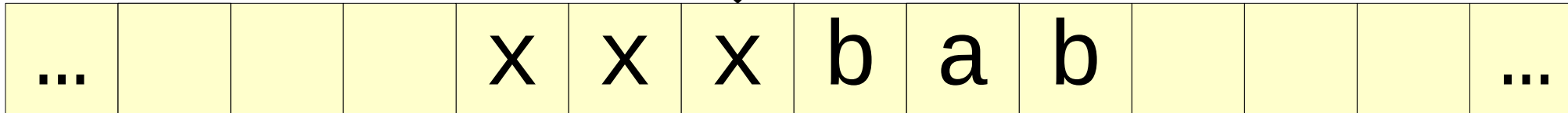
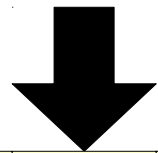

Turing Machines

- A TM stops when executing the

Return *result*

command.

- Here, *result* can be either True or False.
- (If we “fall off” the bottom of the program, the TM acts as though it executes the Return False command.)

Start:

If Blank Return True

If 'b' Return False

Write 'x'

Move Right

If Not 'b' Return False

Write 'x'

Move Right

Goto Start

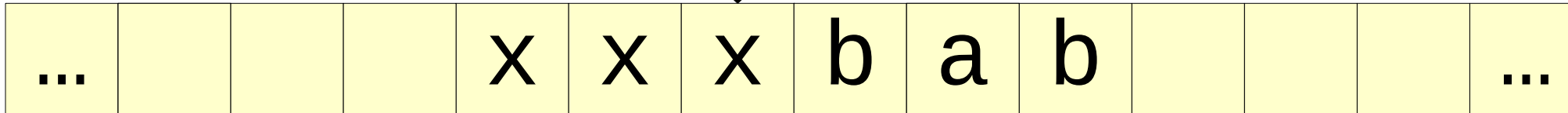
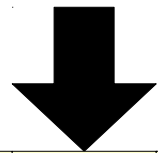

Turing Machines

- A TM stops when executing the **Return *result*** command.
- Here, *result* can be either True or False.
- (If we “fall off” the bottom of the program, the TM acts as though it executes the Return False command.)

```
Start:  
  If Blank Return True  
  If 'b' Return False  
  Write 'x'  
  Move Right  
  If Not 'b' Return False  
  Write 'x'  
  Move Right  
  Goto Start
```

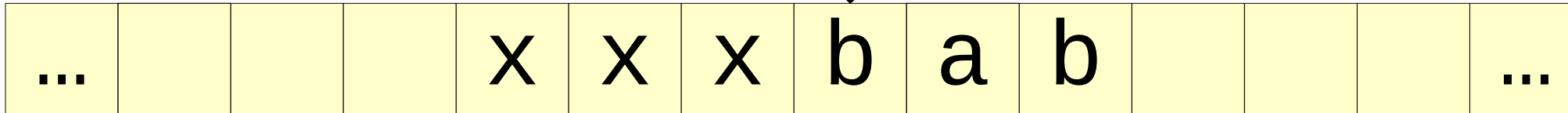

Turing Machines

- A TM stops when executing the **Return *result*** command.
- Here, *result* can be either True or False.
- (If we “fall off” the bottom of the program, the TM acts as though it executes the Return False command.)

```
Start:  
  If Blank Return True  
  If 'b' Return False  
  Write 'x'  
  Move Right  
  If Not 'b' Return False  
  Write 'x'  
  Move Right  
  Goto Start
```

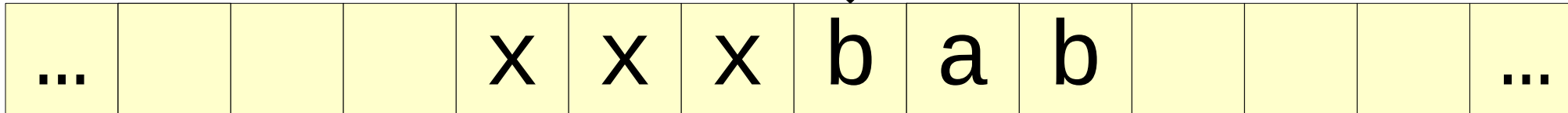

Turing Machines

- A TM stops when executing the **Return *result*** command.
- Here, *result* can be either True or False.
- (If we “fall off” the bottom of the program, the TM acts as though it executes the Return False command.)

```
Start:  
  If Blank Return True  
  If 'b' Return False  
  Write 'x'  
  Move Right  
  If Not 'b' Return False  
  Write 'x'  
  Move Right  
  Goto Start
```

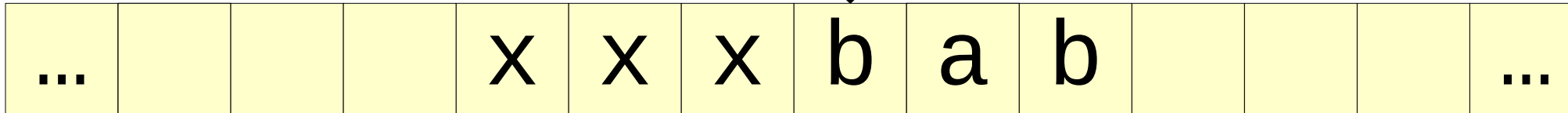

Turing Machines

- A TM stops when executing the **Return *result*** command.
- Here, *result* can be either True or False.
- (If we “fall off” the bottom of the program, the TM acts as though it executes the Return False command.)

```
Start:  
  If Blank Return True  
  If 'b' Return False  
  Write 'x'  
  Move Right  
  If Not 'b' Return False  
  Write 'x'  
  Move Right  
  Goto Start
```

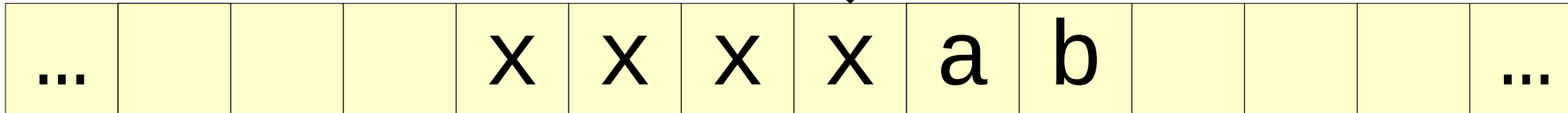

Turing Machines

- A TM stops when executing the **Return *result*** command.
- Here, *result* can be either True or False.
- (If we “fall off” the bottom of the program, the TM acts as though it executes the Return False command.)

```
Start:  
  If Blank Return True  
  If 'b' Return False  
  Write 'x'  
  Move Right  
  If Not 'b' Return False  
  Write 'x'  
  Move Right  
  Goto Start
```

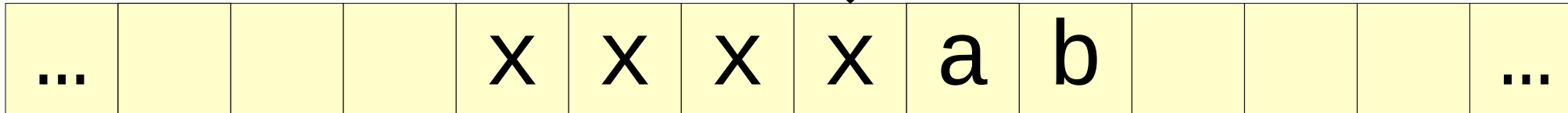

Turing Machines

- A TM stops when executing the **Return *result*** command.
- Here, *result* can be either True or False.
- (If we “fall off” the bottom of the program, the TM acts as though it executes the Return False command.)

```
Start:  
  If Blank Return True  
  If 'b' Return False  
  Write 'x'  
  Move Right  
  If Not 'b' Return False  
  Write 'x'  
  Move Right  
  Goto Start
```

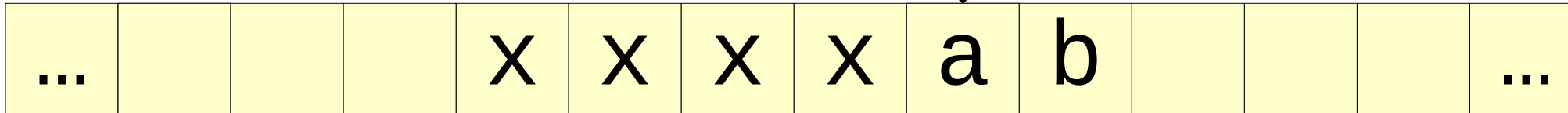

Turing Machines

- A TM stops when executing the **Return *result*** command.
- Here, *result* can be either True or False.
- (If we “fall off” the bottom of the program, the TM acts as though it executes the Return False command.)

```
Start:  
  If Blank Return True  
  If 'b' Return False  
  Write 'x'  
  Move Right  
  If Not 'b' Return False  
  Write 'x'  
  Move Right  
  Goto Start
```

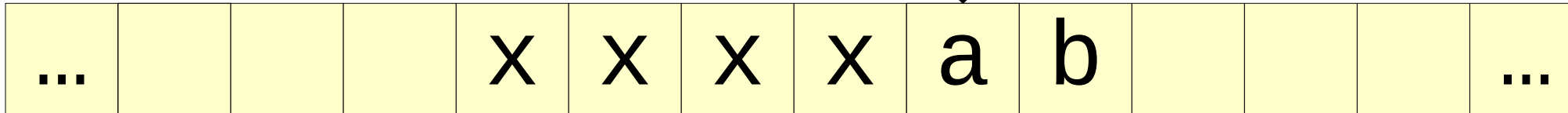

Turing Machines

- A TM stops when executing the **Return *result*** command.
- Here, *result* can be either True or False.
- (If we “fall off” the bottom of the program, the TM acts as though it executes the Return False command.)

Start:

```
If Blank Return True
If 'b' Return False
Write 'x'
Move Right
If Not 'b' Return False
Write 'x'
Move Right
Goto Start
```

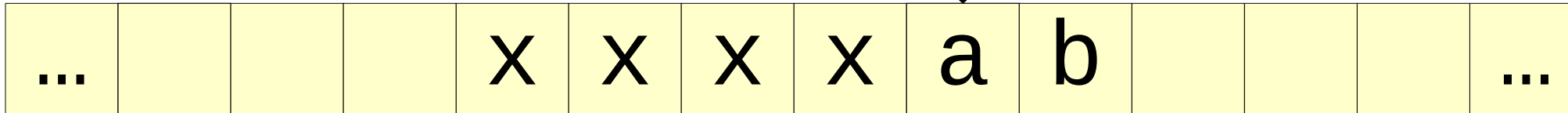

Turing Machines

- A TM stops when executing the **Return *result*** command.
- Here, *result* can be either True or False.
- (If we “fall off” the bottom of the program, the TM acts as though it executes the Return False command.)

```
Start:  
If Blank Return True  
If 'b' Return False  
Write 'x'  
Move Right  
If Not 'b' Return False  
Write 'x'  
Move Right  
Goto Start
```

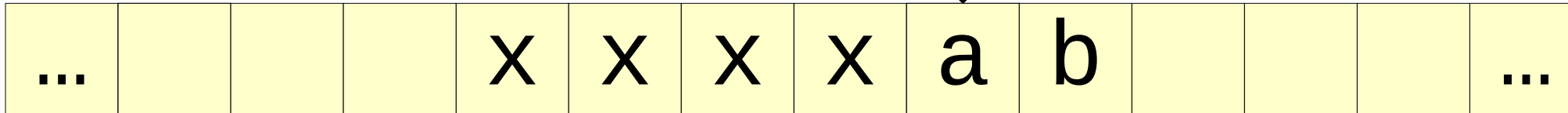

Turing Machines

- A TM stops when executing the **Return *result*** command.
- Here, *result* can be either True or False.
- (If we “fall off” the bottom of the program, the TM acts as though it executes the Return False command.)

```
Start:  
  If Blank Return True  
  If 'b' Return False  
  Write 'x'  
  Move Right  
  If Not 'b' Return False  
  Write 'x'  
  Move Right  
  Goto Start
```

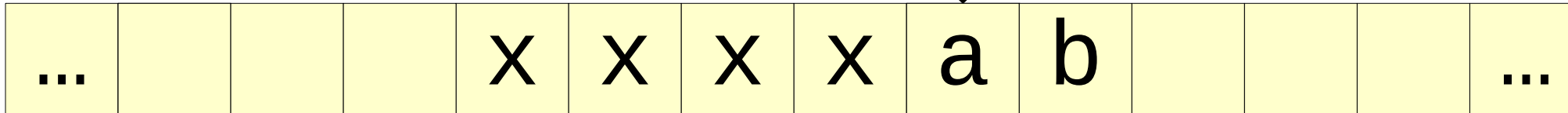

Turing Machines

- A TM stops when executing the **Return *result*** command.
- Here, *result* can be either True or False.
- (If we “fall off” the bottom of the program, the TM acts as though it executes the Return False command.)

```
Start:  
  If Blank Return True  
  If 'b' Return False  
  Write 'x'  
  Move Right  
  If Not 'b' Return False  
  Write 'x'  
  Move Right  
  Goto Start
```

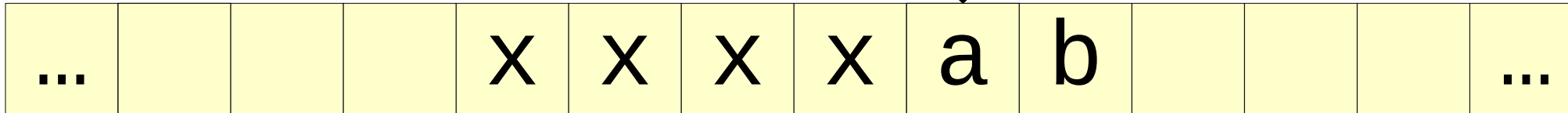

Turing Machines

- A TM stops when executing the **Return *result*** command.
- Here, *result* can be either True or False.
- (If we “fall off” the bottom of the program, the TM acts as though it executes the Return False command.)

```
Start:  
  If Blank Return True  
  If 'b' Return False  
  Write 'x'  
  Move Right  
  If Not 'b' Return False  
  Write 'x'  
  Move Right  
  Goto Start
```

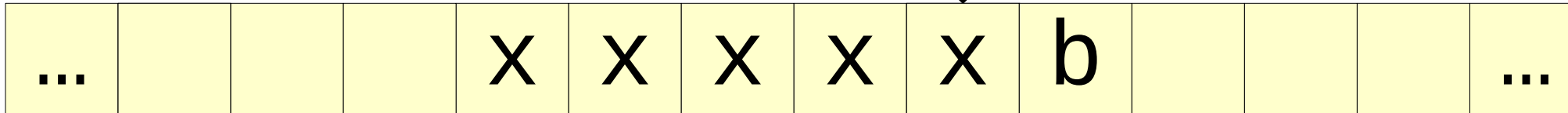

Turing Machines

- A TM stops when executing the **Return *result*** command.
- Here, *result* can be either True or False.
- (If we “fall off” the bottom of the program, the TM acts as though it executes the Return False command.)

```
Start:  
  If Blank Return True  
  If 'b' Return False  
  Write 'x'  
  Move Right  
  If Not 'b' Return False  
  Write 'x'  
  Move Right  
  Goto Start
```

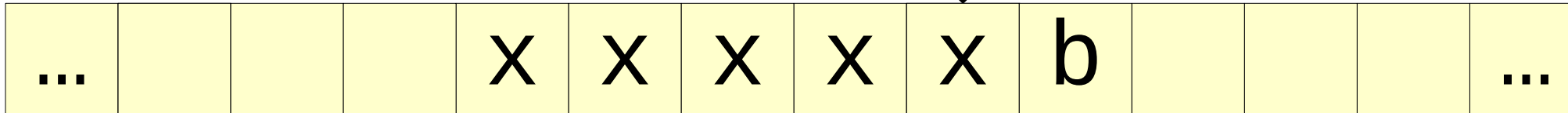

Turing Machines

- A TM stops when executing the **Return *result*** command.
- Here, *result* can be either True or False.
- (If we “fall off” the bottom of the program, the TM acts as though it executes the Return False command.)

```
Start:  
  If Blank Return True  
  If 'b' Return False  
  Write 'x'  
  Move Right  
  If Not 'b' Return False  
  Write 'x'  
  Move Right  
  Goto Start
```

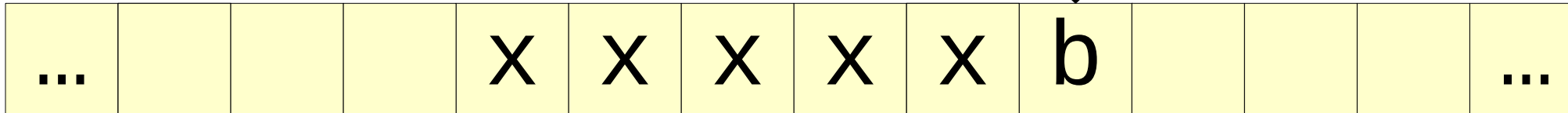

Turing Machines

- A TM stops when executing the **Return *result*** command.
- Here, *result* can be either True or False.
- (If we “fall off” the bottom of the program, the TM acts as though it executes the Return False command.)

```
Start:  
  If Blank Return True  
  If 'b' Return False  
  Write 'x'  
  Move Right  
  If Not 'b' Return False  
  Write 'x'  
  Move Right  
  Goto Start
```

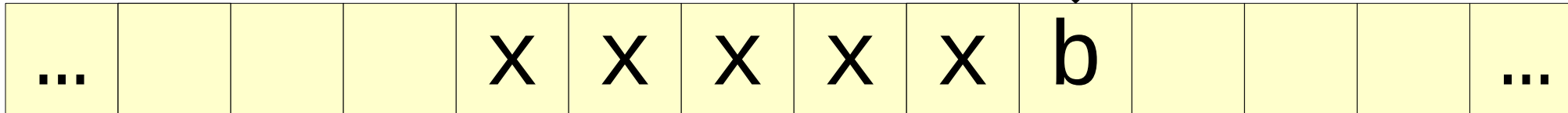

Turing Machines

- A TM stops when executing the **Return *result*** command.
- Here, *result* can be either True or False.
- (If we “fall off” the bottom of the program, the TM acts as though it executes the Return False command.)

```
Start:  
  If Blank Return True  
  If 'b' Return False  
  Write 'x'  
  Move Right  
  If Not 'b' Return False  
  Write 'x'  
  Move Right  
  Goto Start
```

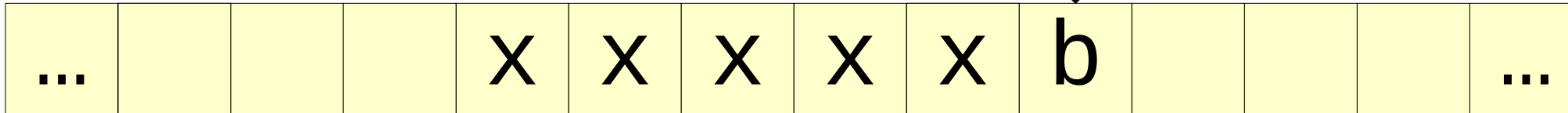

Turing Machines

- A TM stops when executing the **Return *result*** command.
- Here, *result* can be either True or False.
- (If we “fall off” the bottom of the program, the TM acts as though it executes the Return False command.)

```
Start:  
  If Blank Return True  
  If 'b' Return False  
  Write 'x'  
  Move Right  
  If Not 'b' Return False  
  Write 'x'  
  Move Right  
  Goto Start
```

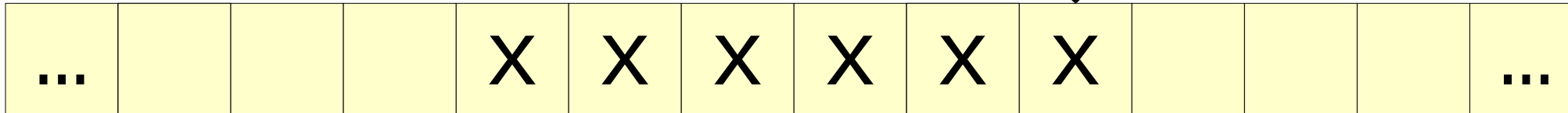

Turing Machines

- A TM stops when executing the **Return *result*** command.
- Here, *result* can be either True or False.
- (If we “fall off” the bottom of the program, the TM acts as though it executes the Return False command.)

```
Start:  
  If Blank Return True  
  If 'b' Return False  
  Write 'x'  
  Move Right  
  If Not 'b' Return False  
  Write 'x'  
  Move Right  
  Goto Start
```

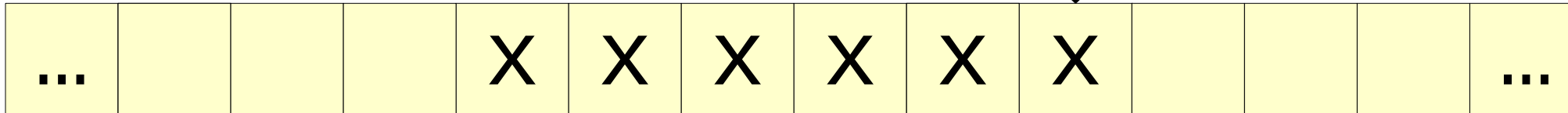

Turing Machines

- A TM stops when executing the **Return *result*** command.
- Here, *result* can be either True or False.
- (If we “fall off” the bottom of the program, the TM acts as though it executes the Return False command.)

```
Start:  
  If Blank Return True  
  If 'b' Return False  
  Write 'x'  
  Move Right  
  If Not 'b' Return False  
  Write 'x'  
  Move Right  
  Goto Start
```

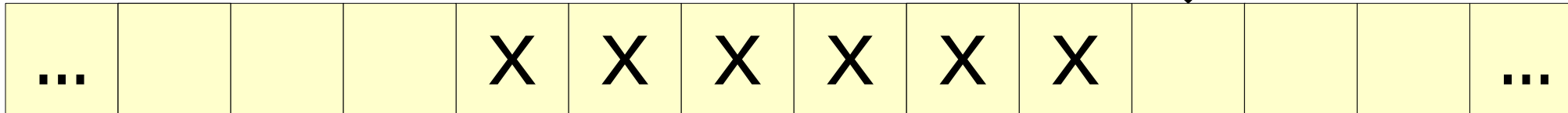

Turing Machines

- A TM stops when executing the **Return *result*** command.
- Here, *result* can be either True or False.
- (If we “fall off” the bottom of the program, the TM acts as though it executes the Return False command.)

```
Start:  
  If Blank Return True  
  If 'b' Return False  
  Write 'x'  
  Move Right  
  If Not 'b' Return False  
  Write 'x'  
  Move Right  
  Goto Start
```

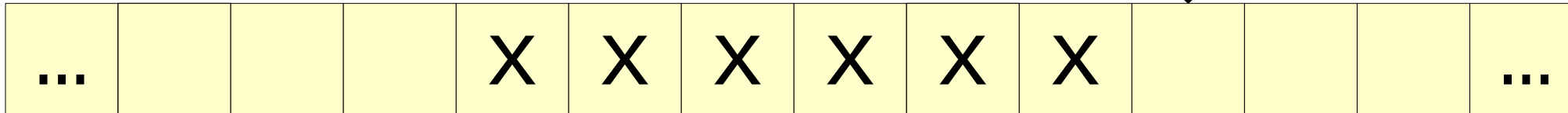

Turing Machines

- A TM stops when executing the **Return *result*** command.
- Here, *result* can be either True or False.
- (If we “fall off” the bottom of the program, the TM acts as though it executes the Return False command.)

Start:

```
If Blank Return True
If 'b' Return False
Write 'x'
Move Right
If Not 'b' Return False
Write 'x'
Move Right
Goto Start
```

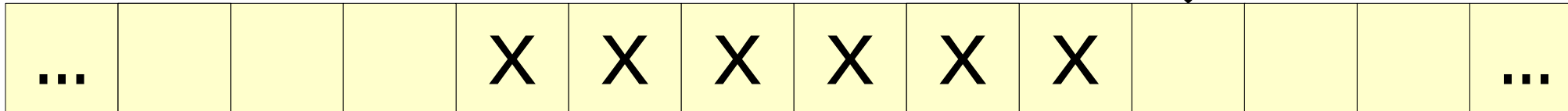
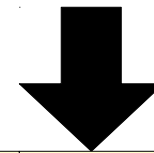

Turing Machines

- A TM stops when executing the

Return *result*

command.

- Here, *result* can be either True or False.
- (If we “fall off” the bottom of the program, the TM acts as though it executes the Return False command.)

Start:

If Blank Return True

If 'b' Return False

Write 'x'

Move Right

If Not 'b' Return False

Write 'x'

Move Right

Goto Start

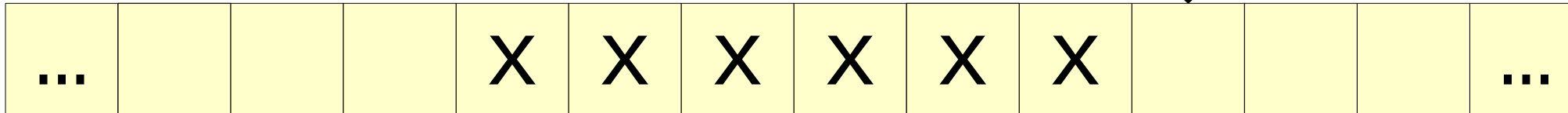
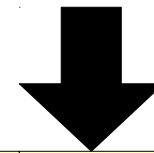

Turing Machines

- A TM stops when executing the **Return *result*** command.
- Here, *result* can be either True or False.
- (If we “fall off” the bottom of the program, the TM acts as though it executes the Return False command.)

Start:

If Blank Return True



If 'b' Return False

Write 'x'

Move Right

If Not 'b' Return False

Write 'x'

Move Right

Goto Start

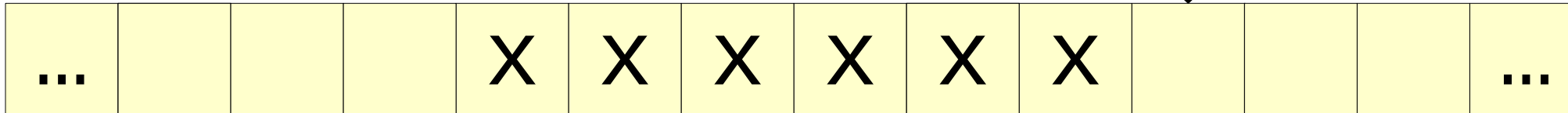
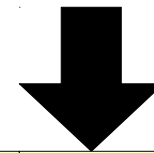

Turing Machines

- This TM initially started up with the string ababab on its tape, so this means that TM returns true on the input ababab, not xxxxxx.
- An intuition for this: we gave this program an input. It therefore returned true with respect to that input, not whatever internal data it generated in making its decision.

Start:

If Blank Return True



If 'b' Return False

Write 'x'

Move Right

If Not 'b' Return False

Write 'x'

Move Right

Goto Start

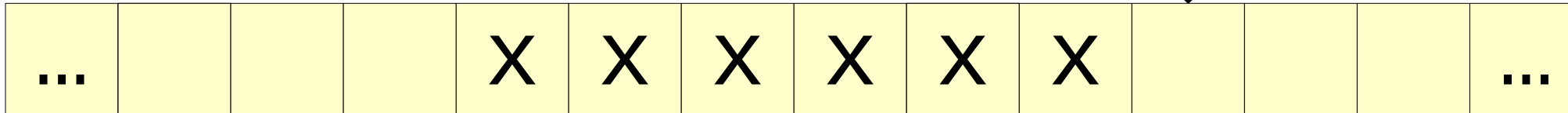
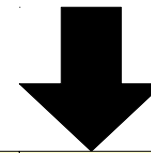

Turing Machines

- To summarize, we only have six commands:
 - Move *direction*
 - Write *symbol*
 - Goto *label*
 - Return *result*
 - If *symbol command*
 - If Not *symbol command*
- Despite their simplicity, TMs are *surprisingly* powerful. The rest of this lecture explores why.

```
Start:  
  If Blank Return True  
  If 'b' Return False  
  Write 'x'  
  Move Right  
  If Not 'b' Return False  
  Write 'x'  
  Move Right  
  Goto Start
```

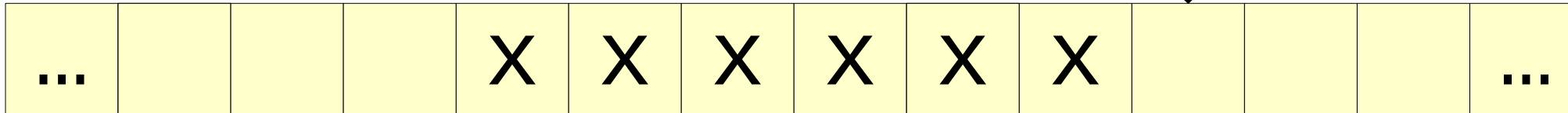
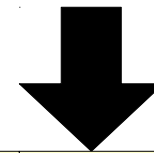

Languages of Turing Machines

- We just saw a TM whose language is equivalent to the regex $(ab)^*$
- This is a regular language (Q: how do we know?)
- Are TMs capable of recognizing non-regular languages?

```
Start:
```

```
  If Blank Return True
```

```
  If 'b' Return False
```

```
  Write 'x'
```

```
  Move Right
```

```
  If Not 'b' Return False
```

```
  Write 'x'
```

```
  Move Right
```

```
  Goto Start
```

Programming Turing Machines: Can They Do Non-Regular Languages?

Our First Challenge

- The language

$$\{ \mathbf{a}^n \mathbf{b}^n \mid n \in \mathbb{N} \}$$

is a canonical example of a nonregular language. It's not possible to check if a string is in this language given only finite memory.

- Turing machines, however, are powerful enough to do this. Let's see how.

$$L = \{ \mathbf{a}^n \mathbf{b}^n \mid n \in \mathbb{N} \}$$

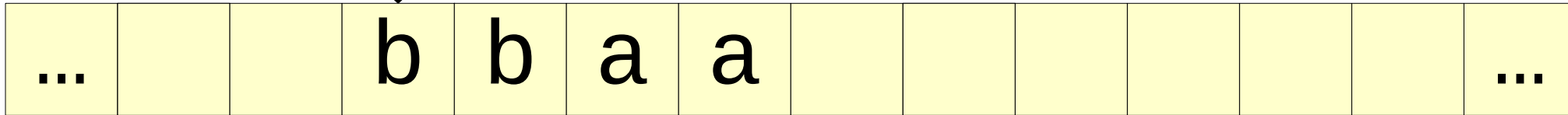
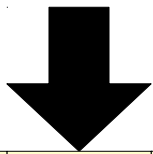
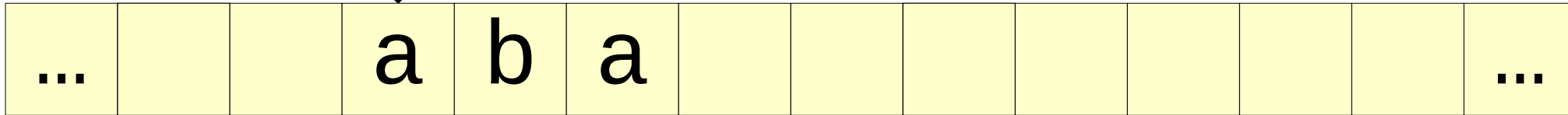
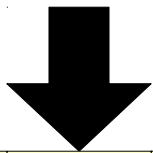
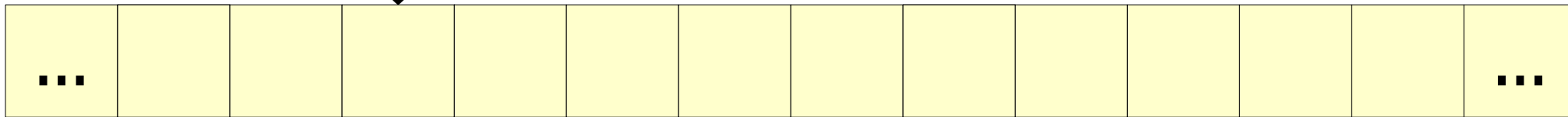
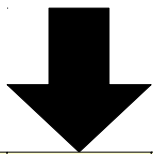
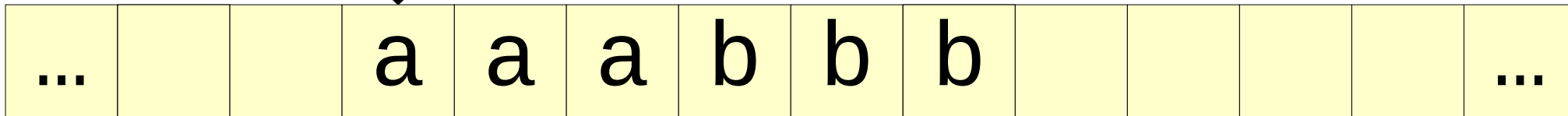
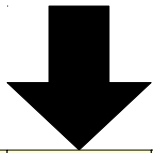

A Recursive Approach

- We can process our string using this recursive approach:
 - The string ε is in L .
 - The string **a** w **b** is in L if and only if w is in L .
 - Any string starting with **b** is not in L .
 - Any string ending with **a** is not in L .
- All that's left to do now is write a TM that implements this.

A Sketch of our TM

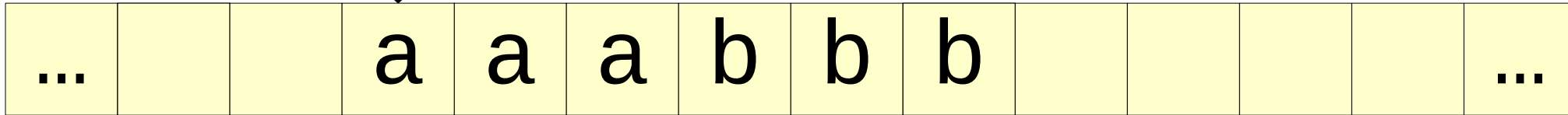
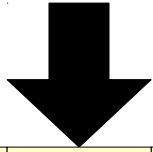

A Sketch of our TM

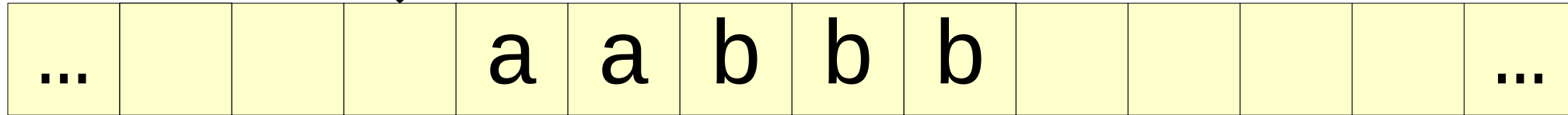
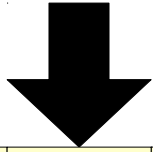

A Sketch of our TM

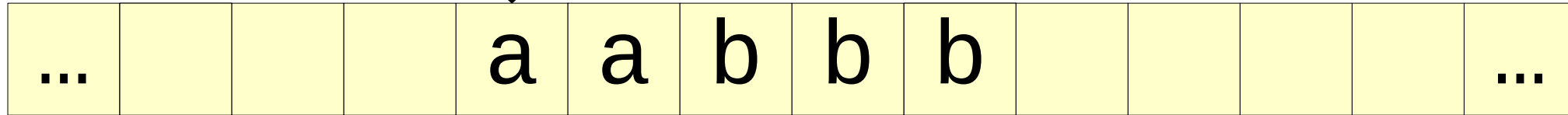
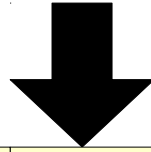

A Sketch of our TM

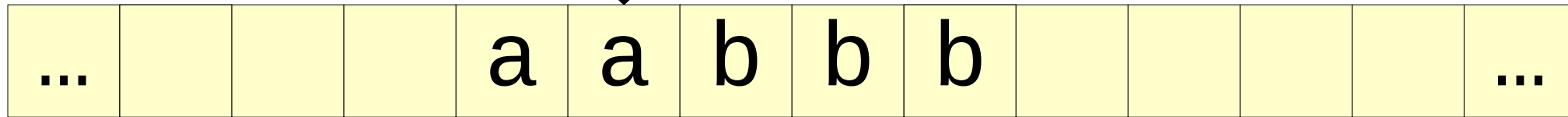
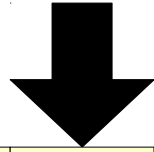

A Sketch of our TM

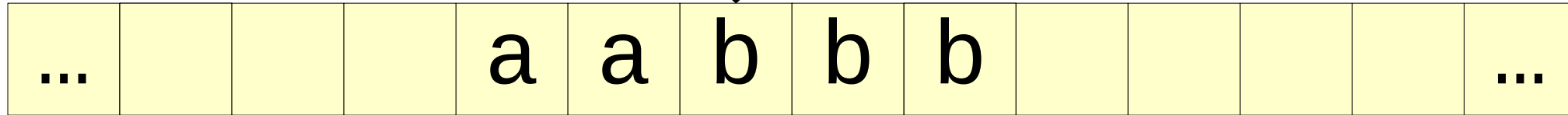
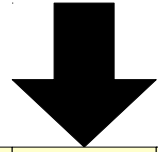

A Sketch of our TM

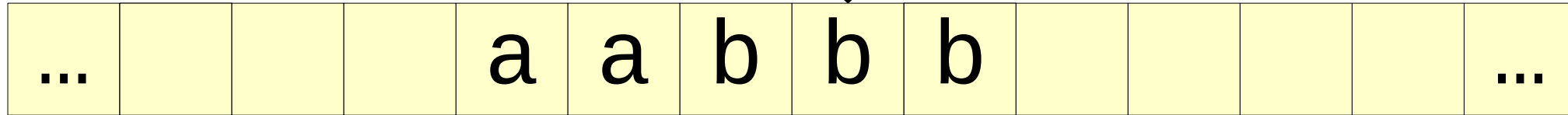
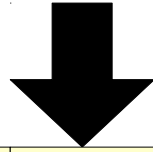

A Sketch of our TM

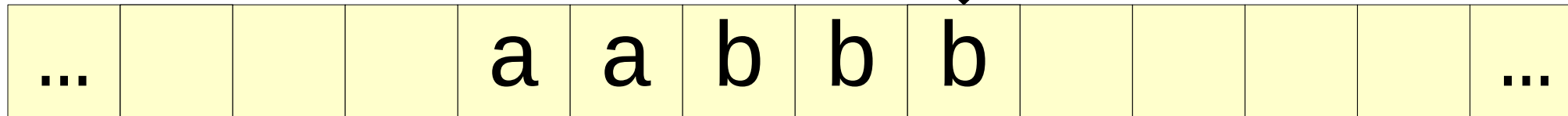
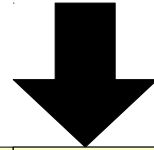

A Sketch of our TM

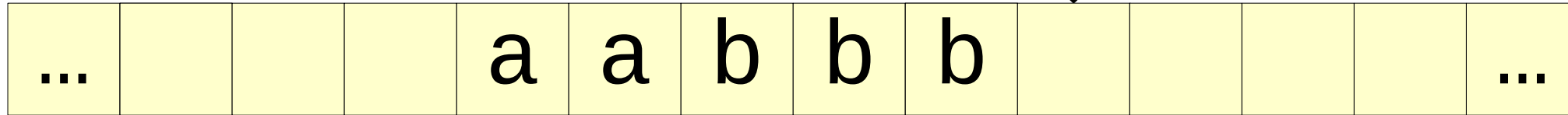
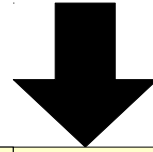

A Sketch of our TM

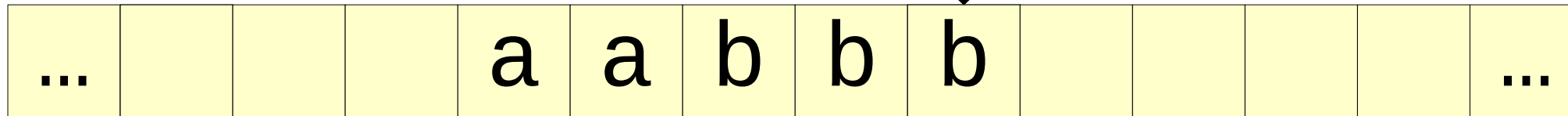
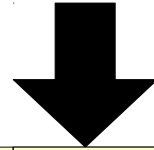

A Sketch of our TM

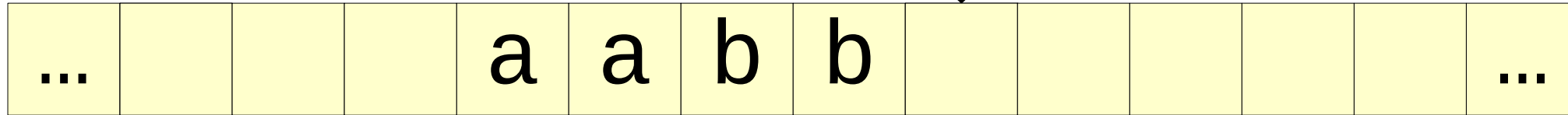
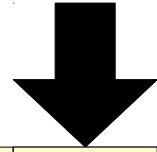

A Sketch of our TM

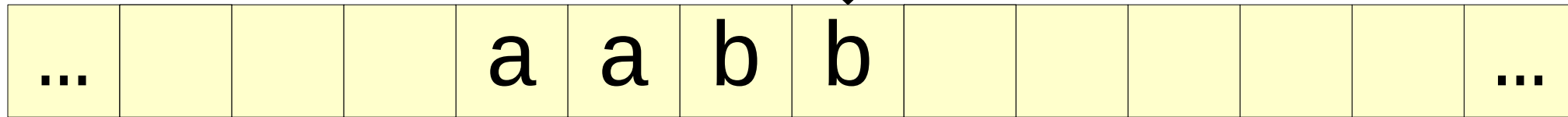
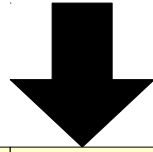

A Sketch of our TM

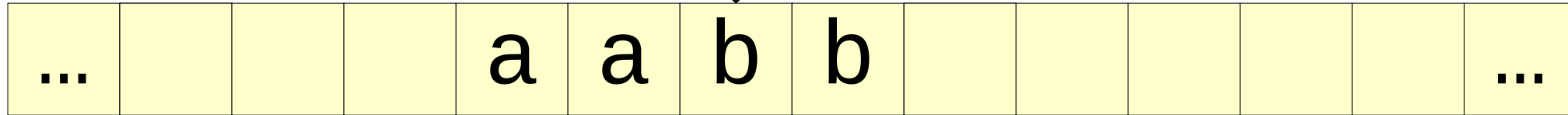
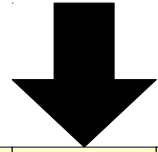

A Sketch of our TM

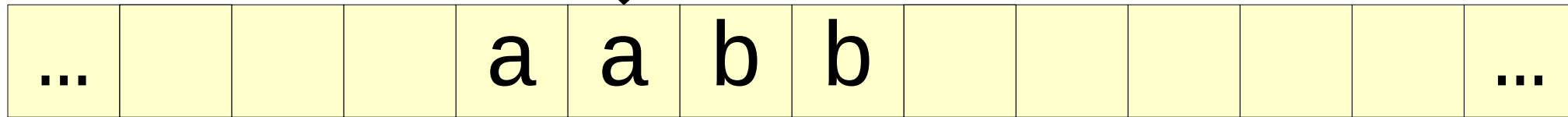
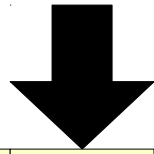

A Sketch of our TM

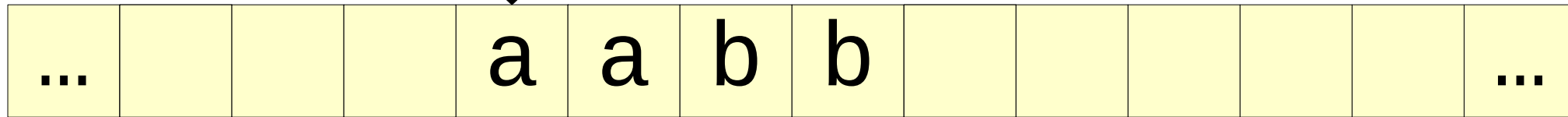
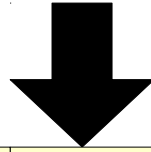

A Sketch of our TM

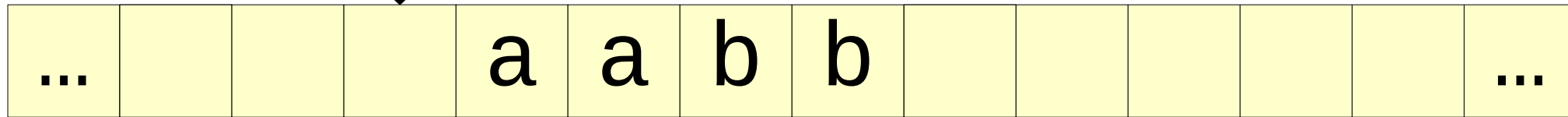
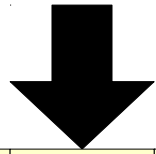

A Sketch of our TM

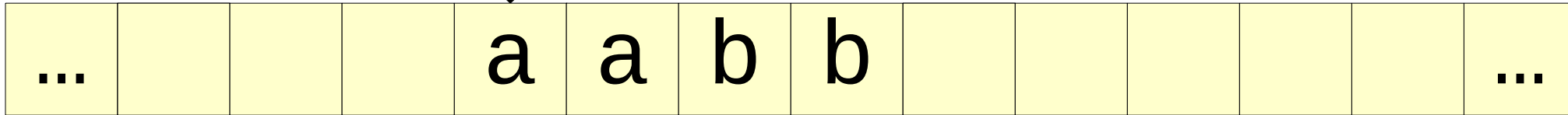
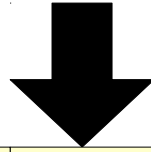

A Sketch of our TM

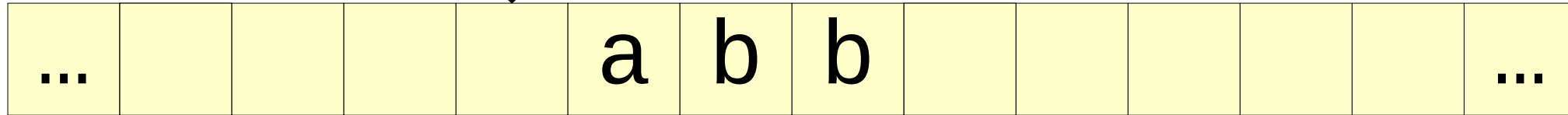
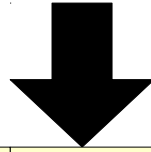

A Sketch of our TM

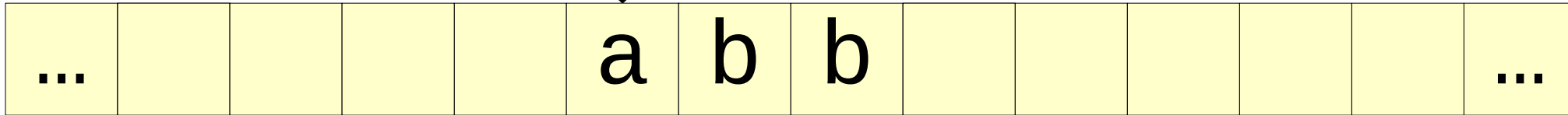
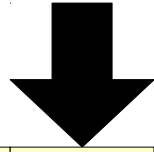

A Sketch of our TM

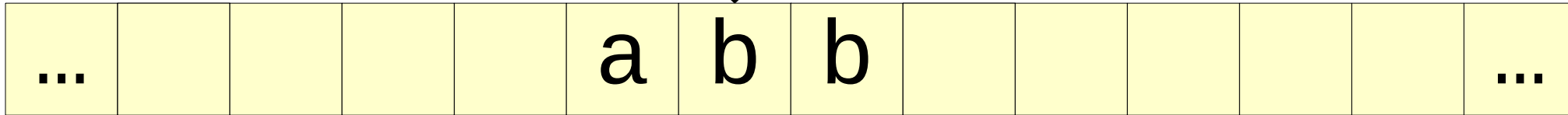
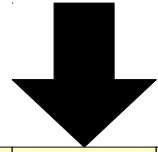

A Sketch of our TM

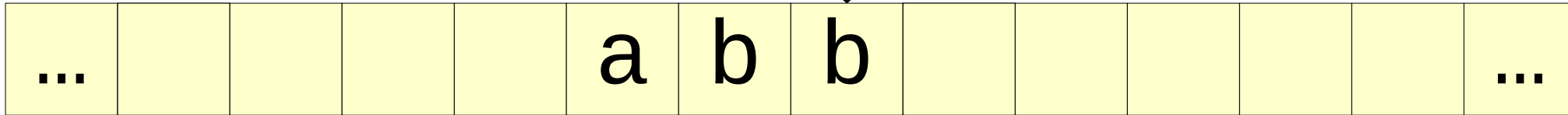
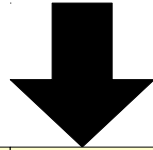

A Sketch of our TM

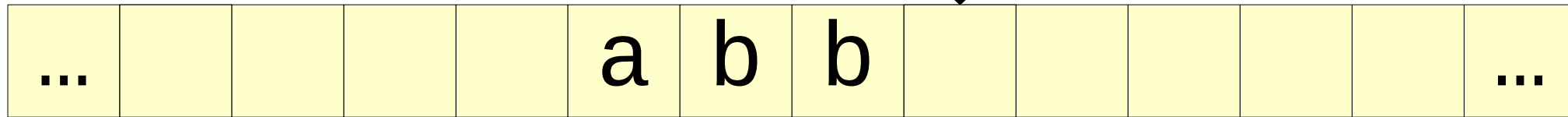
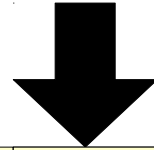

A Sketch of our TM

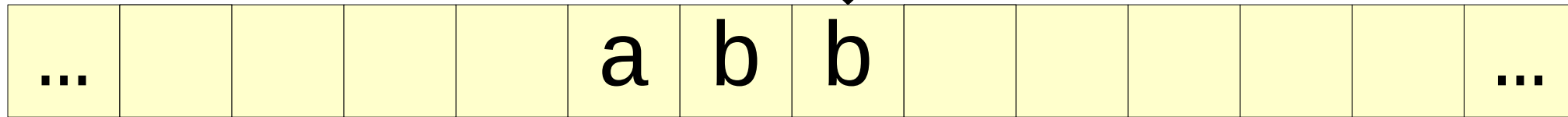
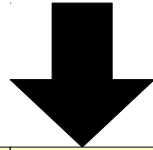

A Sketch of our TM

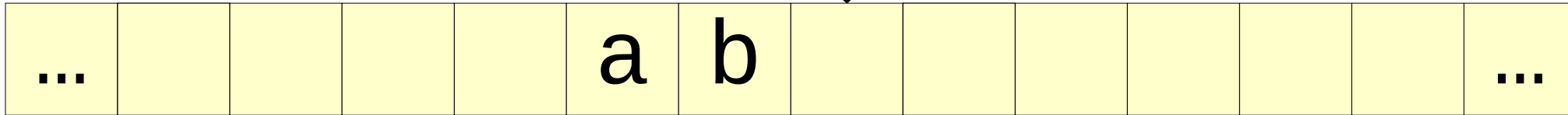
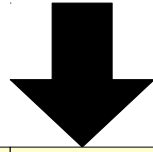

A Sketch of our TM

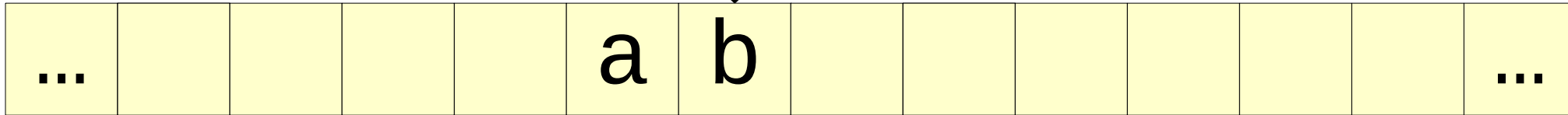
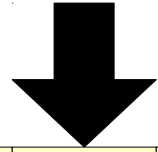

A Sketch of our TM

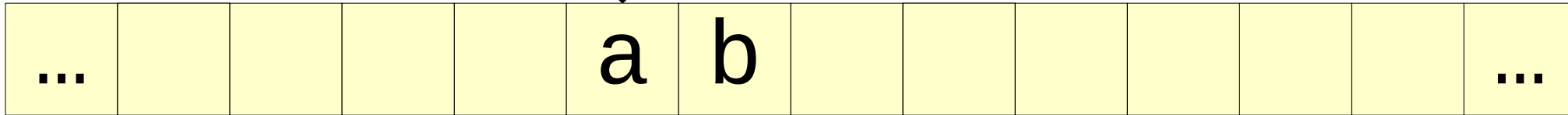
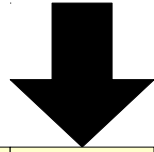

A Sketch of our TM

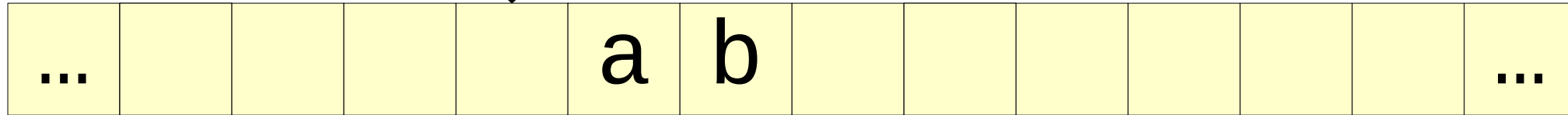
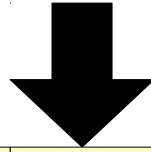

A Sketch of our TM

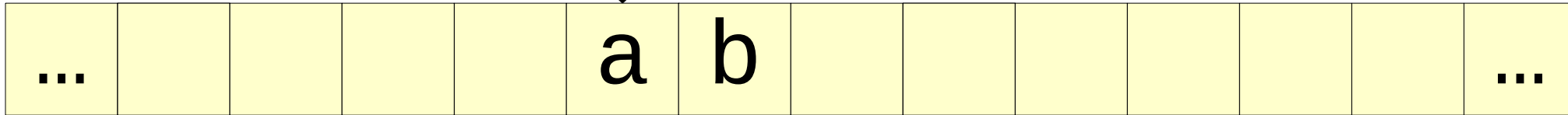
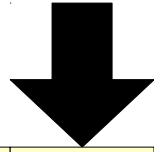

A Sketch of our TM

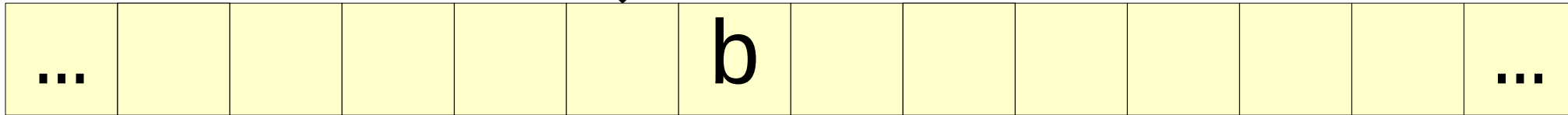
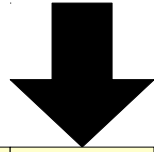

A Sketch of our TM

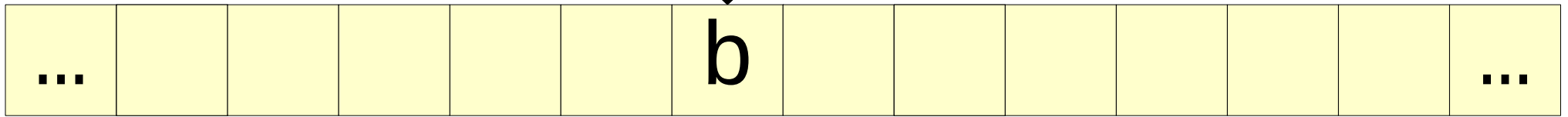
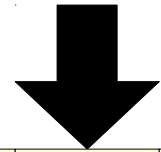

A Sketch of our TM

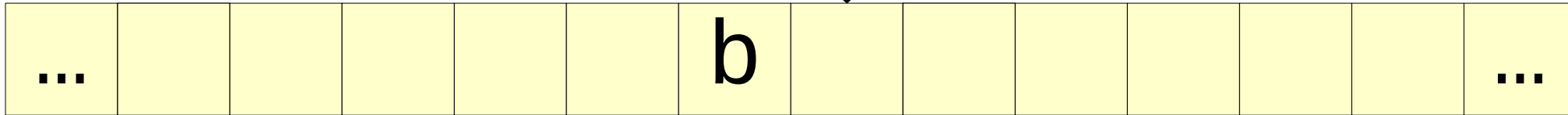
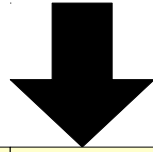

A Sketch of our TM

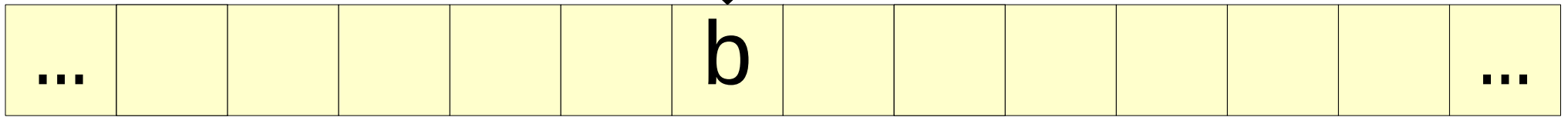
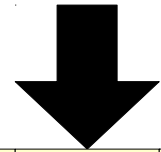

A Sketch of our TM

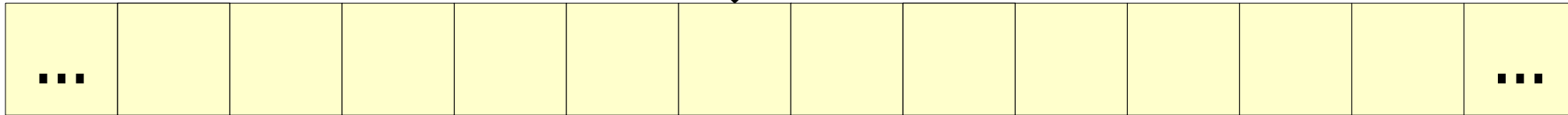
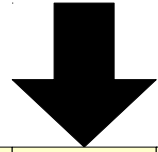

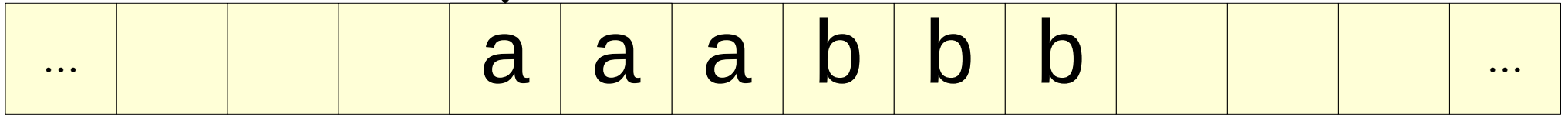

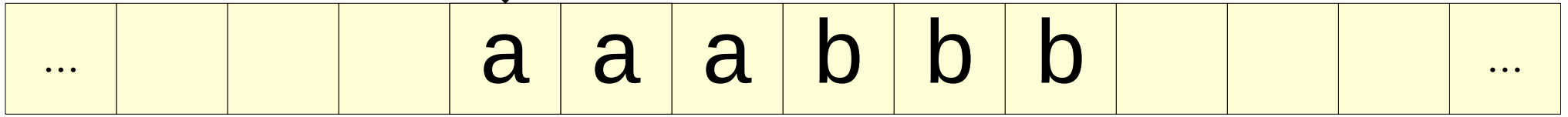
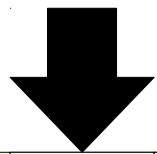
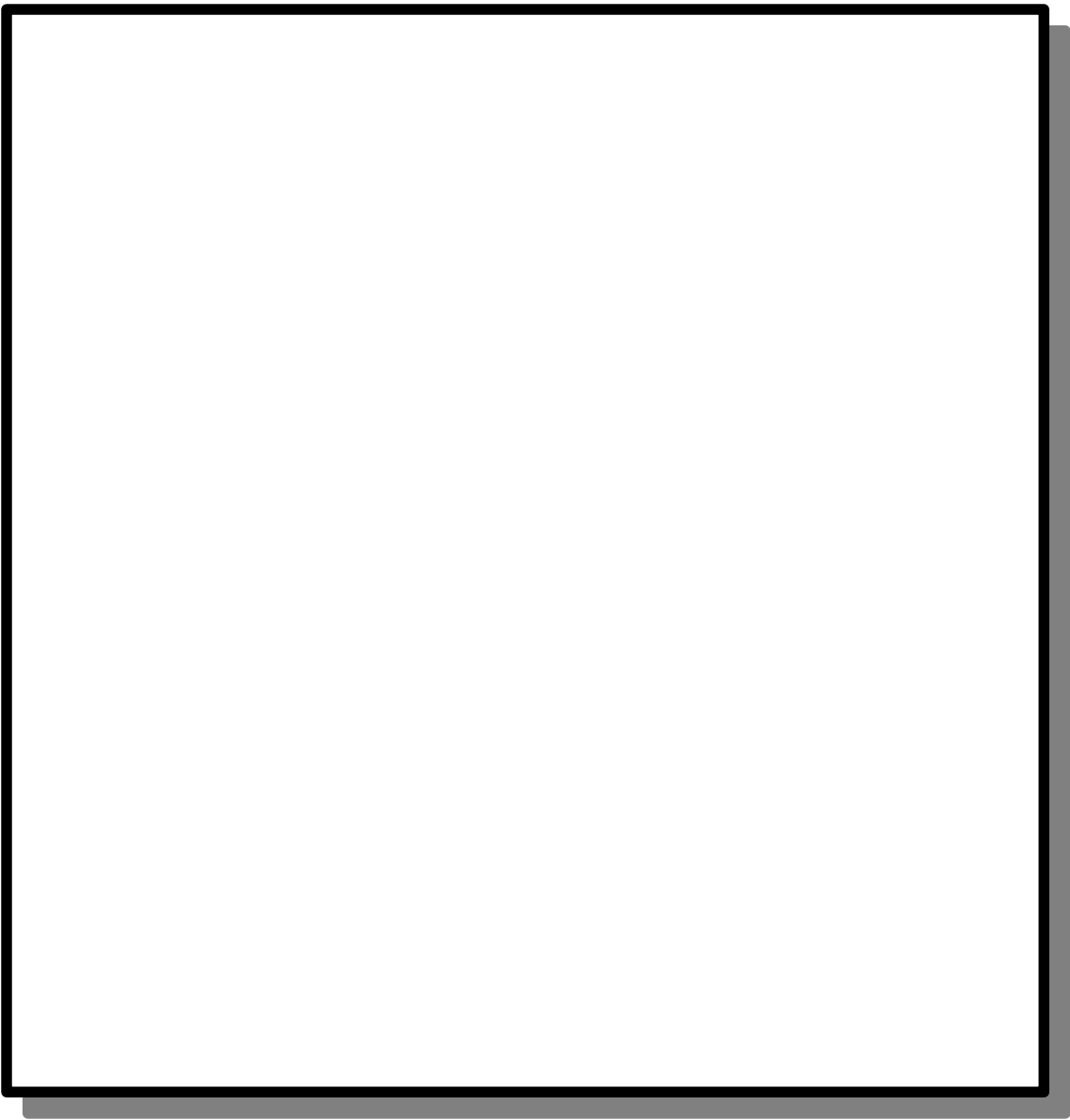

Start:

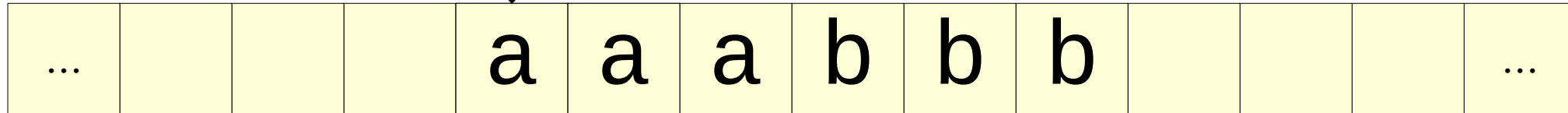
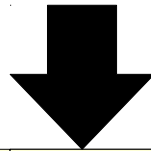

Start:

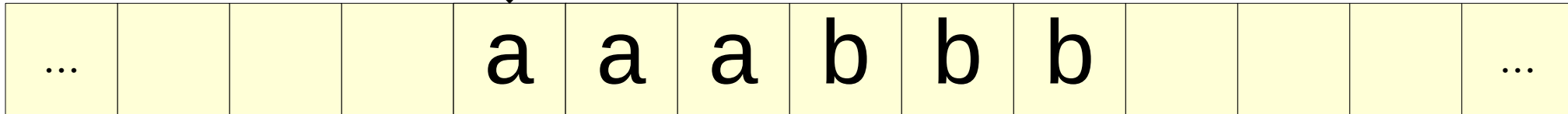
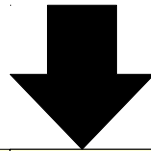

Start:

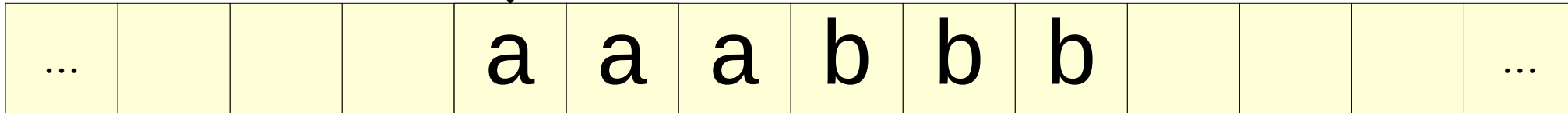
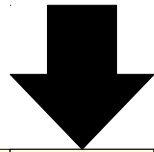

Start:

If Blank Return True

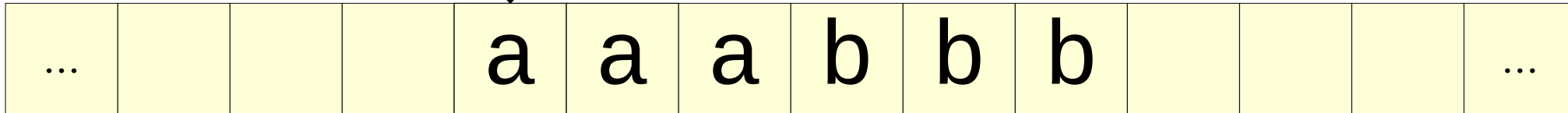
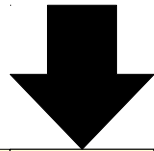

Start:
If Blank Return True

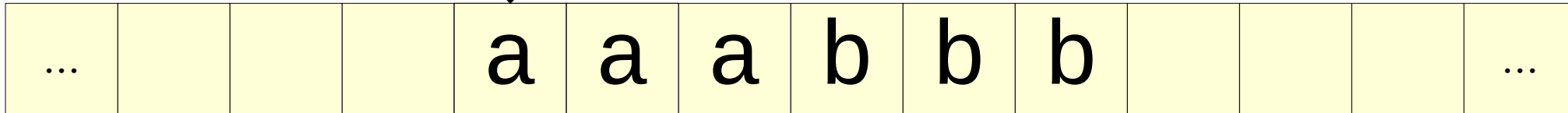
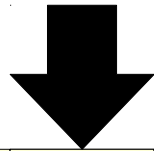

```
Start:  
  If Blank Return True  
  If 'b' Return False
```

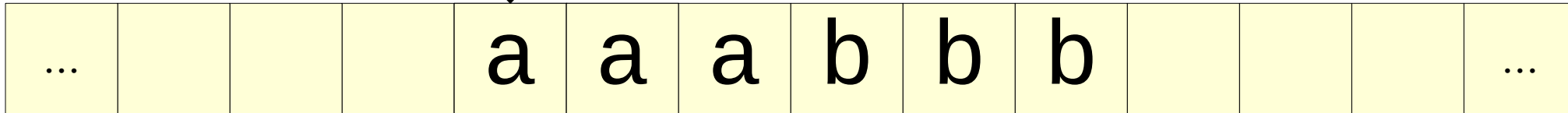
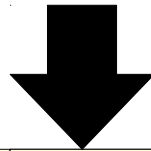

```
Start:  
  If Blank Return True  
  If 'b' Return False
```

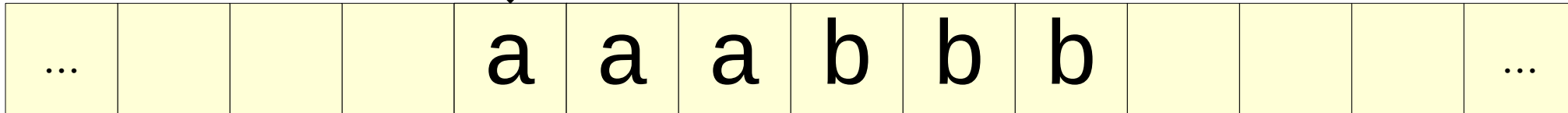
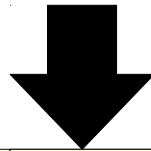

```
Start:  
  If Blank Return True  
  If 'b' Return False  
  Write Blank
```

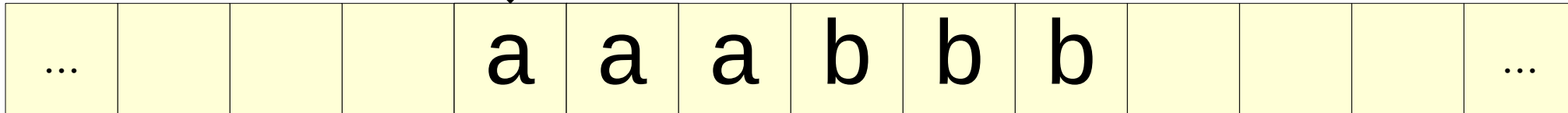
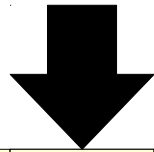

```
Start:  
  If Blank Return True  
  If 'b' Return False  
  Write Blank
```

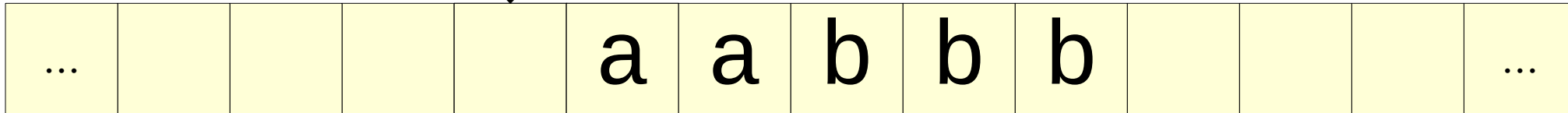
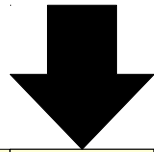

```
Start:  
  If Blank Return True  
  If 'b' Return False  
  Write Blank
```

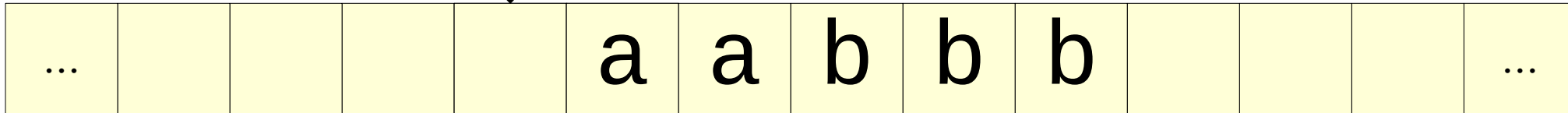
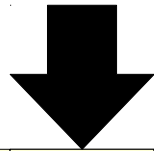

```
Start:  
  If Blank Return True  
  If 'b' Return False  
  Write Blank
```

ZipRight:

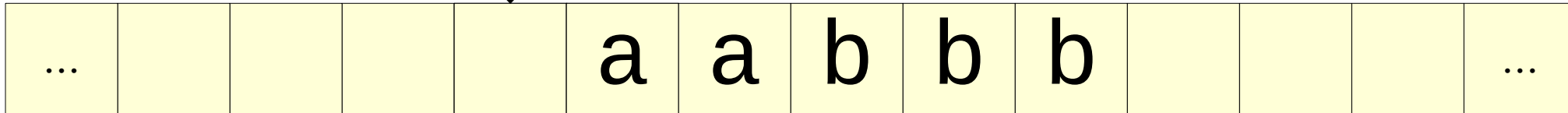
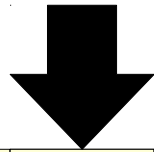

```
Start:  
  If Blank Return True  
  If 'b' Return False  
  Write Blank
```

ZipRight:

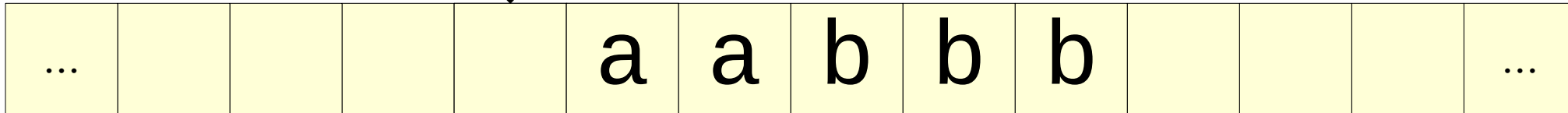
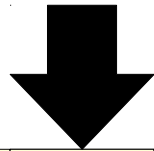

```
Start:  
  If Blank Return True  
  If 'b' Return False  
  Write Blank
```

```
ZipRight:  
  Move Right
```

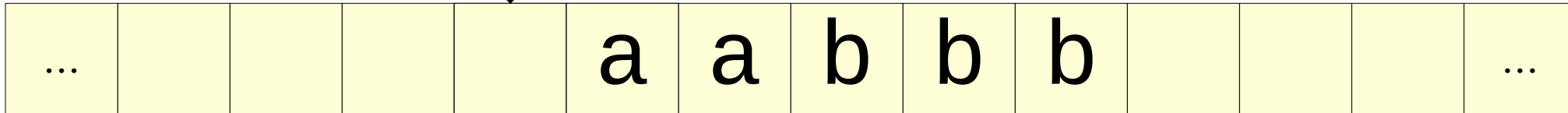
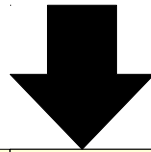

```
Start:  
  If Blank Return True  
  If 'b' Return False  
  Write Blank
```

```
ZipRight:  
  Move Right
```

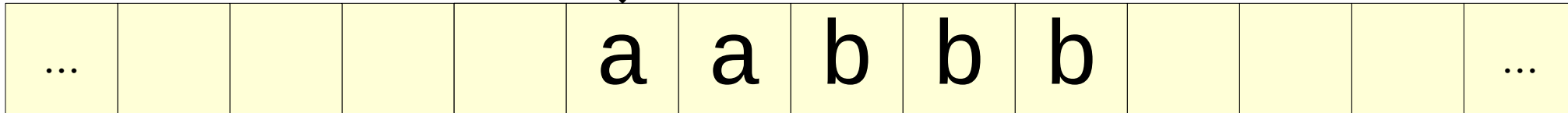
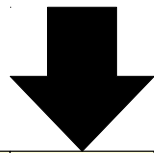

```
Start:  
  If Blank Return True  
  If 'b' Return False  
  Write Blank
```

```
ZipRight:  
  Move Right
```

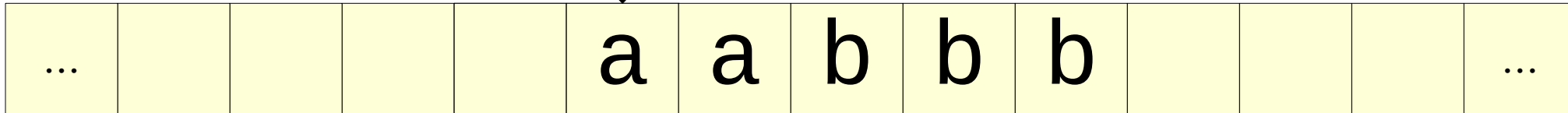
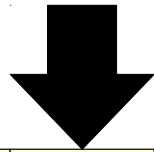

```
Start:  
  If Blank Return True  
  If 'b' Return False  
  Write Blank  
  
ZipRight:  
  Move Right  
  If Not Blank Goto ZipRight
```

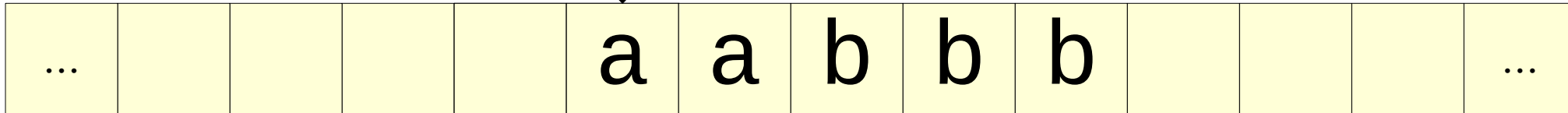
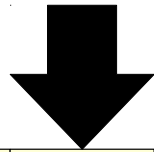

```
Start:  
  If Blank Return True  
  If 'b' Return False  
  Write Blank
```

ZipRight:

```
  Move Right  
  If Not Blank Goto ZipRight
```

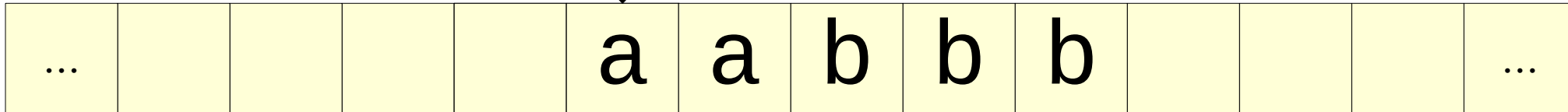
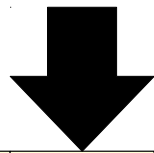

```
Start:  
  If Blank Return True  
  If 'b' Return False  
  Write Blank  
  
ZipRight:  
  Move Right  
  If Not Blank Goto ZipRight
```

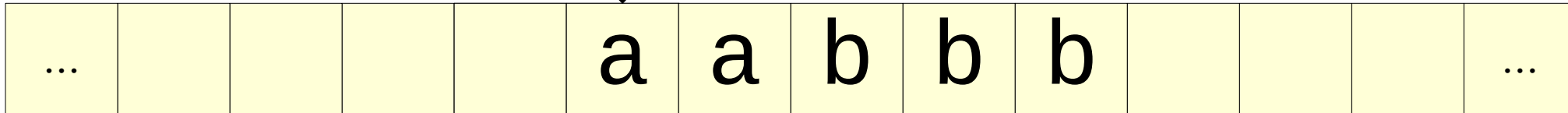
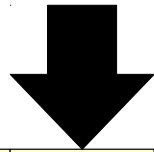

```
Start:  
  If Blank Return True  
  If 'b' Return False  
  Write Blank  
  
ZipRight:  
  Move Right  
  If Not Blank Goto ZipRight
```

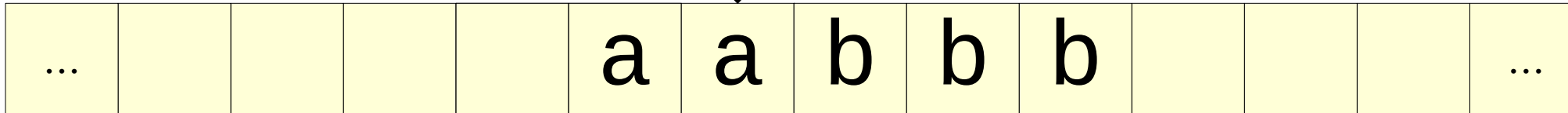
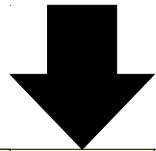

```
Start:  
  If Blank Return True  
  If 'b' Return False  
  Write Blank  
  
ZipRight:  
  Move Right  
  If Not Blank Goto ZipRight
```

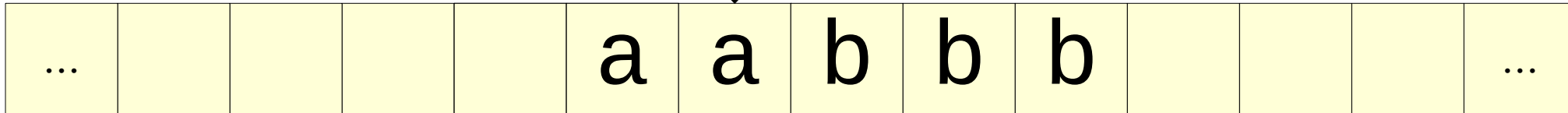
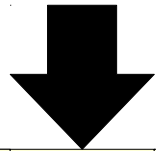

```
Start:  
  If Blank Return True  
  If 'b' Return False  
  Write Blank
```

```
ZipRight:
```

```
  Move Right  
  If Not Blank Goto ZipRight
```

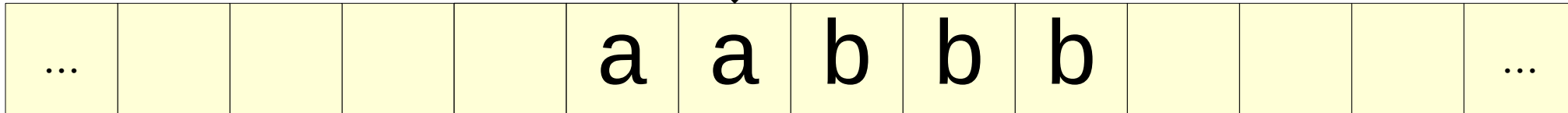
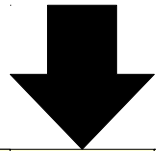

```
Start:  
  If Blank Return True  
  If 'b' Return False  
  Write Blank  
  
ZipRight:  
  Move Right  
  If Not Blank Goto ZipRight
```

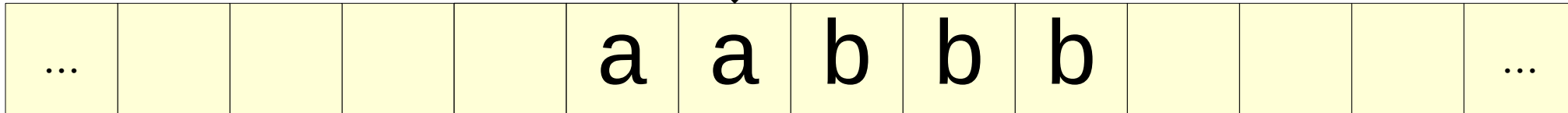
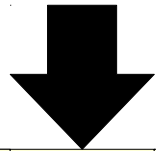

```
Start:  
  If Blank Return True  
  If 'b' Return False  
  Write Blank  
  
ZipRight:  
  Move Right  
  If Not Blank Goto ZipRight
```

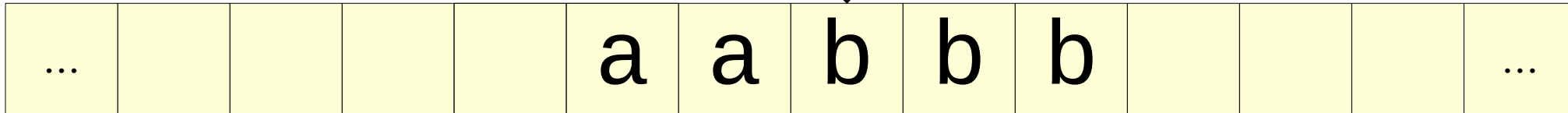

```
Start:  
  If Blank Return True  
  If 'b' Return False  
  Write Blank  
  
ZipRight:  
  Move Right  
  If Not Blank Goto ZipRight
```

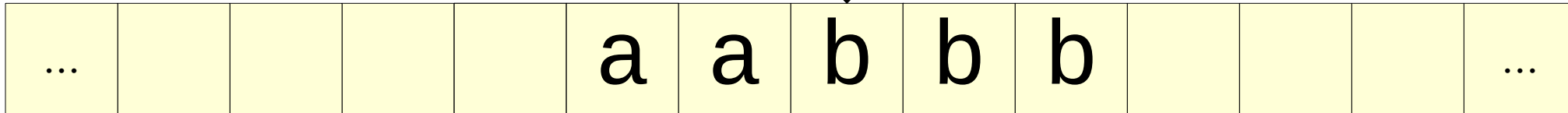

```
Start:  
  If Blank Return True  
  If 'b' Return False  
  Write Blank
```

```
ZipRight:  
  Move Right  
  If Not Blank Goto ZipRight
```

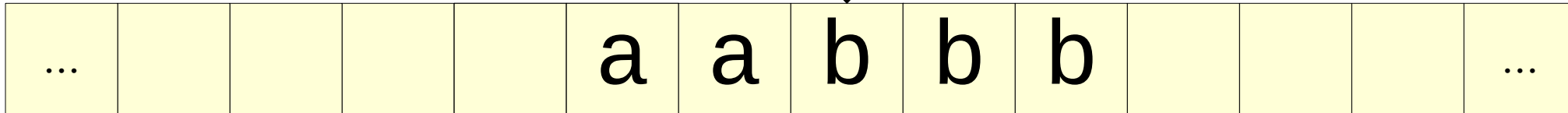

```
Start:  
  If Blank Return True  
  If 'b' Return False  
  Write Blank  
  
ZipRight:  
  Move Right  
  If Not Blank Goto ZipRight
```

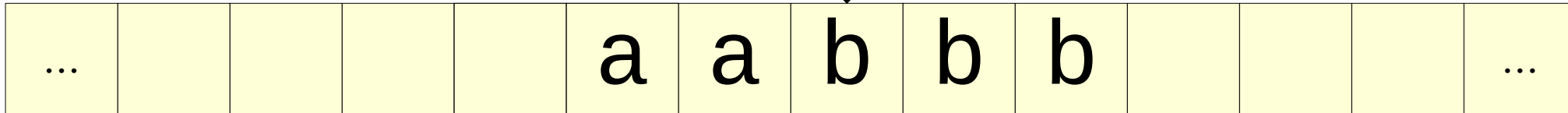

```
Start:  
  If Blank Return True  
  If 'b' Return False  
  Write Blank  
  
ZipRight:  
  Move Right  
  If Not Blank Goto ZipRight
```

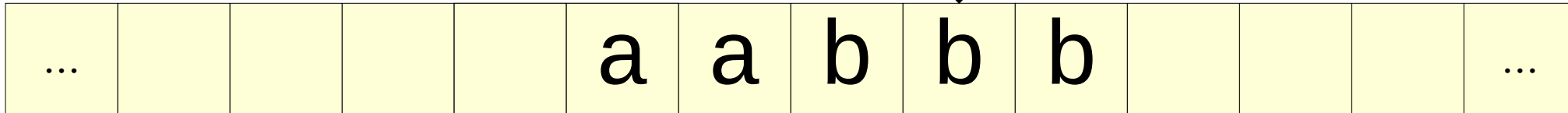

```
Start:  
  If Blank Return True  
  If 'b' Return False  
  Write Blank  
  
ZipRight:  
  Move Right  
  If Not Blank Goto ZipRight
```

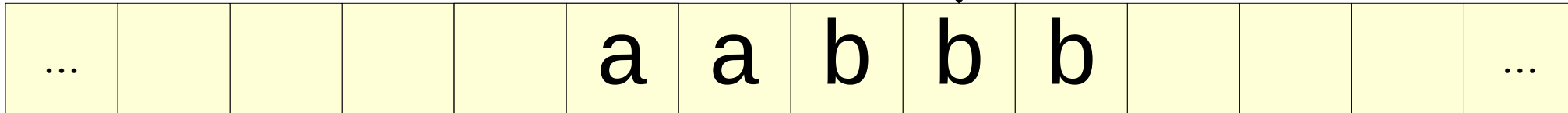
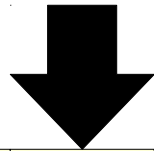

```
Start:  
  If Blank Return True  
  If 'b' Return False  
  Write Blank
```

```
ZipRight:  
  Move Right  
  If Not Blank Goto ZipRight
```

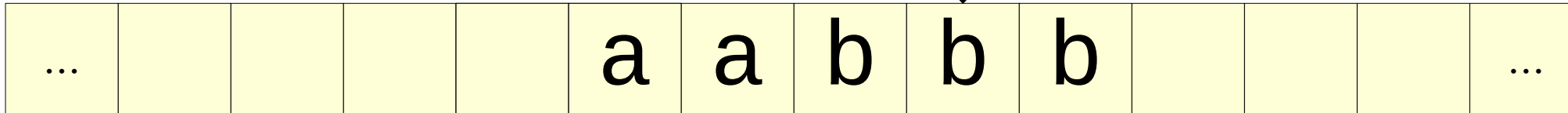
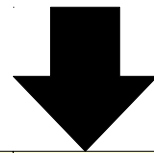

```
Start:  
  If Blank Return True  
  If 'b' Return False  
  Write Blank  
  
ZipRight:  
  Move Right  
  If Not Blank Goto ZipRight
```

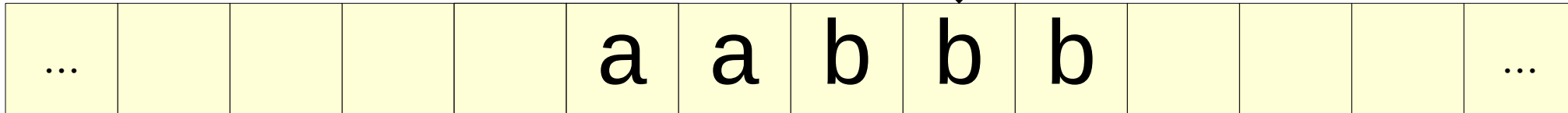

```
Start:  
  If Blank Return True  
  If 'b' Return False  
  Write Blank  
  
ZipRight:  
  Move Right  
  If Not Blank Goto ZipRight
```

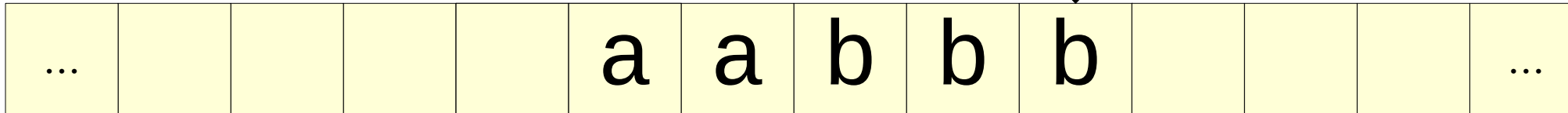
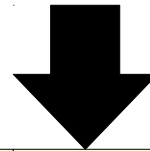

```
Start:  
  If Blank Return True  
  If 'b' Return False  
  Write Blank  
  
ZipRight:  
  Move Right  
  If Not Blank Goto ZipRight
```

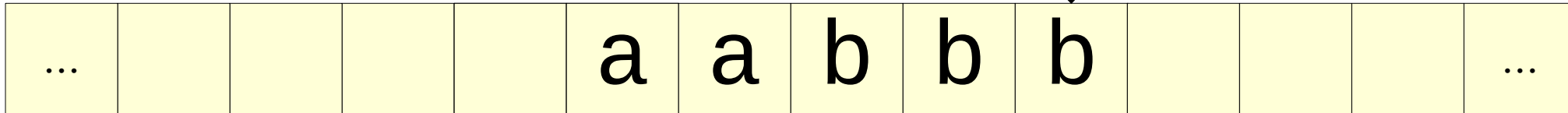
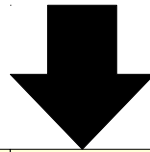

```
Start:  
  If Blank Return True  
  If 'b' Return False  
  Write Blank
```

```
ZipRight:  
  Move Right  
  If Not Blank Goto ZipRight
```

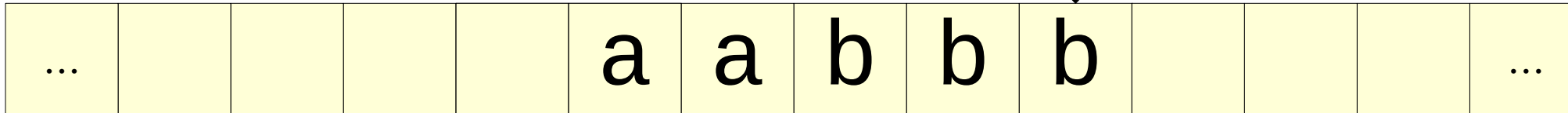
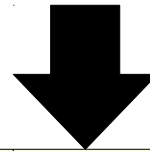

```
Start:  
  If Blank Return True  
  If 'b' Return False  
  Write Blank  
  
ZipRight:  
  Move Right  
  If Not Blank Goto ZipRight
```

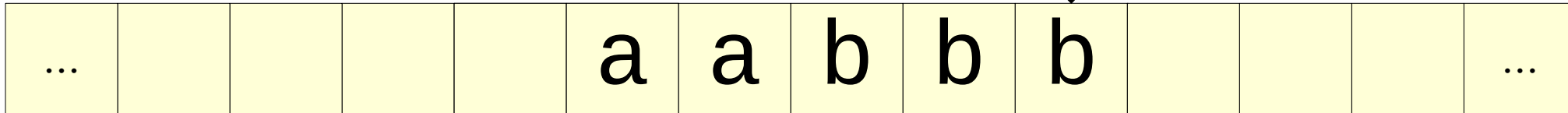
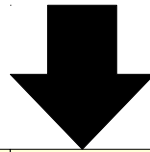

```
Start:  
  If Blank Return True  
  If 'b' Return False  
  Write Blank  
  
ZipRight:  
  Move Right  
  If Not Blank Goto ZipRight
```

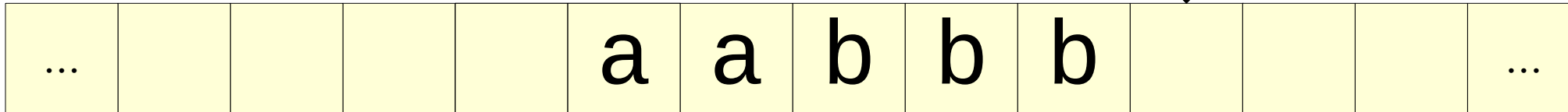
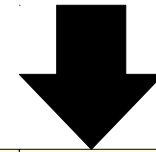

```
Start:  
  If Blank Return True  
  If 'b' Return False  
  Write Blank  
  
ZipRight:  
  Move Right  
  If Not Blank Goto ZipRight
```

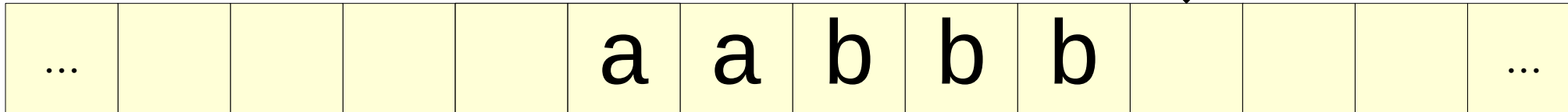
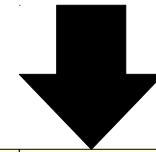

```
Start:  
  If Blank Return True  
  If 'b' Return False  
  Write Blank  
  
ZipRight:  
  Move Right  
  If Not Blank Goto ZipRight
```

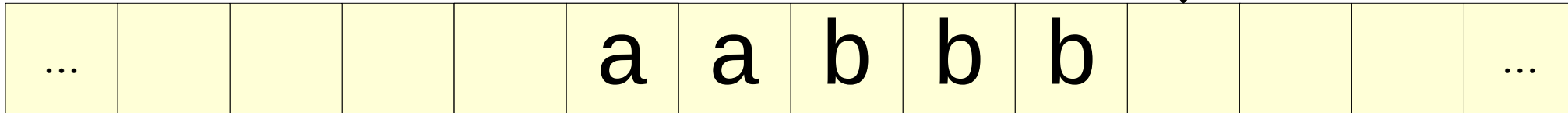

```
Start:  
  If Blank Return True  
  If 'b' Return False  
  Write Blank  
  
ZipRight:  
  Move Right  
  If Not Blank Goto ZipRight  
  Move Left
```

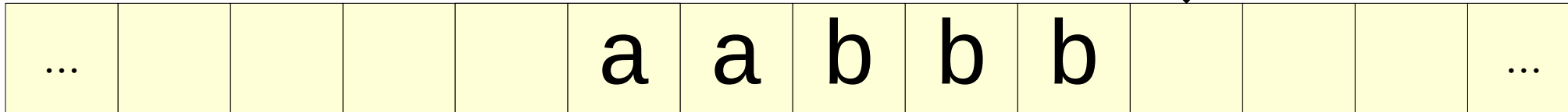
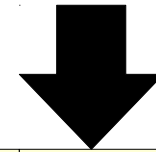

```
Start:  
  If Blank Return True  
  If 'b' Return False  
  Write Blank  
  
ZipRight:  
  Move Right  
  If Not Blank Goto ZipRight  
  Move Left
```

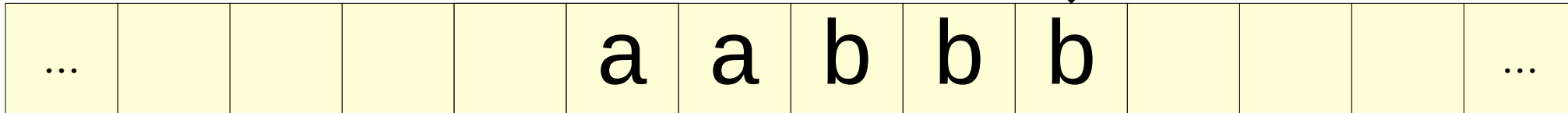
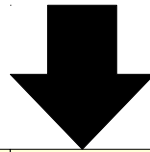

```
Start:  
  If Blank Return True  
  If 'b' Return False  
  Write Blank  
  
ZipRight:  
  Move Right  
  If Not Blank Goto ZipRight  
  Move Left
```

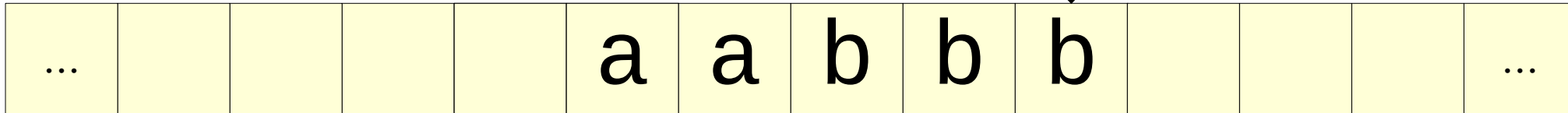
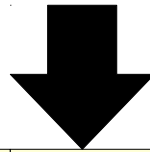

```
Start:  
  If Blank Return True  
  If 'b' Return False  
  Write Blank  
  
ZipRight:  
  Move Right  
  If Not Blank Goto ZipRight  
  Move Left  
  If Not 'b' Return False
```

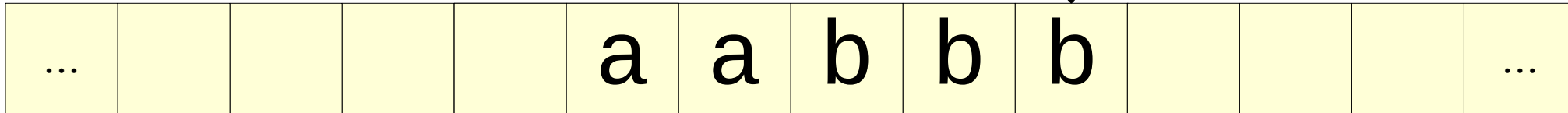
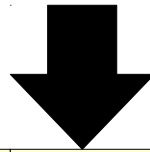

```
Start:  
  If Blank Return True  
  If 'b' Return False  
  Write Blank  
  
ZipRight:  
  Move Right  
  If Not Blank Goto ZipRight  
  Move Left  
  If Not 'b' Return False
```

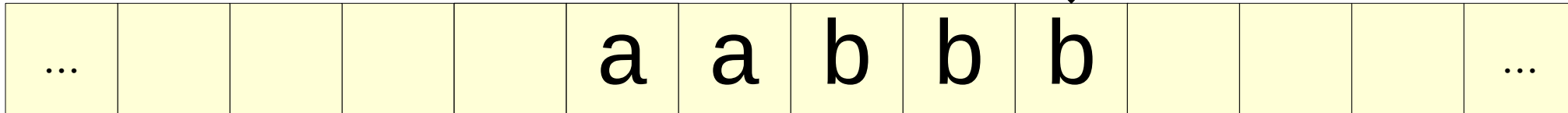
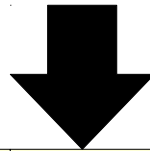

```
Start:  
  If Blank Return True  
  If 'b' Return False  
  Write Blank  
  
ZipRight:  
  Move Right  
  If Not Blank Goto ZipRight  
  Move Left  
  If Not 'b' Return False  
  Write Blank
```

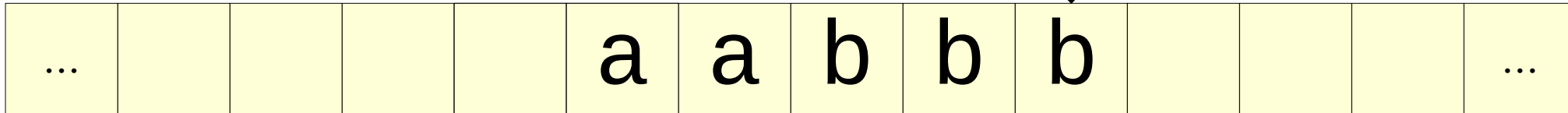
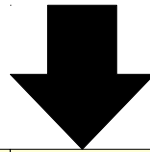

```
Start:  
  If Blank Return True  
  If 'b' Return False  
  Write Blank  
  
ZipRight:  
  Move Right  
  If Not Blank Goto ZipRight  
  Move Left  
  If Not 'b' Return False  
  Write Blank
```

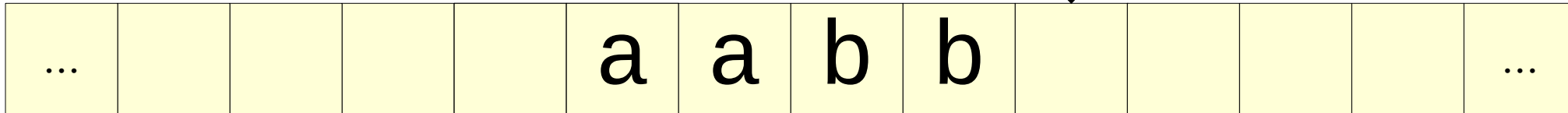
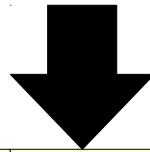

```
Start:  
  If Blank Return True  
  If 'b' Return False  
  Write Blank  
  
ZipRight:  
  Move Right  
  If Not Blank Goto ZipRight  
  Move Left  
  If Not 'b' Return False  
  Write Blank
```

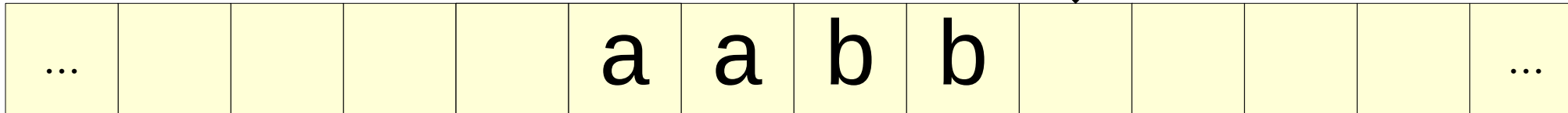
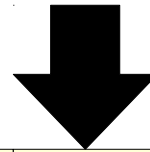

```
Start:  
  If Blank Return True  
  If 'b' Return False  
  Write Blank  
  
ZipRight:  
  Move Right  
  If Not Blank Goto ZipRight  
  Move Left  
  If Not 'b' Return False  
  Write Blank  
  
ZipLeft:  
  Move Left  
  If Not Blank Goto ZipLeft
```

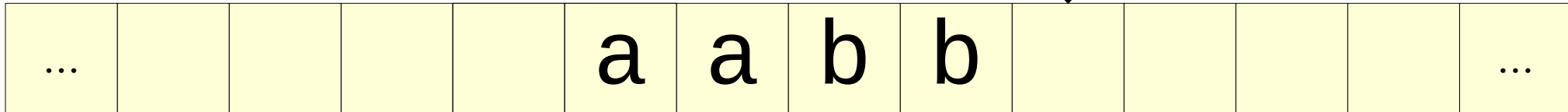
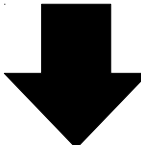

```
Start:  
  If Blank Return True  
  If 'b' Return False  
  Write Blank  
  
ZipRight:  
  Move Right  
  If Not Blank Goto ZipRight  
  Move Left  
  If Not 'b' Return False  
  Write Blank  
  
ZipLeft:  
  Move Left  
  If Not Blank Goto ZipLeft
```

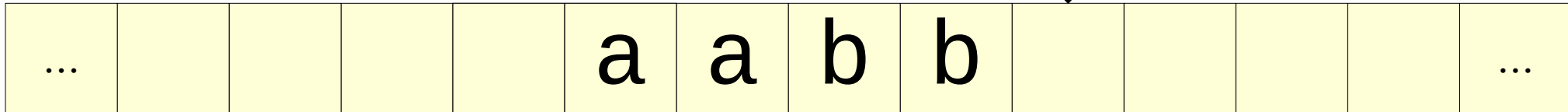
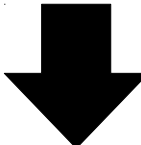

```
Start:  
  If Blank Return True  
  If 'b' Return False  
  Write Blank  
  
ZipRight:  
  Move Right  
  If Not Blank Goto ZipRight  
  Move Left  
  If Not 'b' Return False  
  Write Blank  
  
ZipLeft:  
  Move Left  
  If Not Blank Goto ZipLeft
```

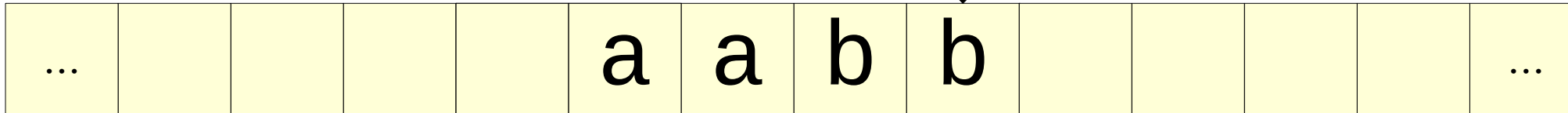
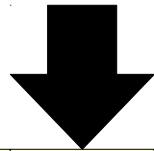

```
Start:  
  If Blank Return True  
  If 'b' Return False  
  Write Blank  
  
ZipRight:  
  Move Right  
  If Not Blank Goto ZipRight  
  Move Left  
  If Not 'b' Return False  
  Write Blank  
  
ZipLeft:  
  Move Left  
  If Not Blank Goto ZipLeft
```

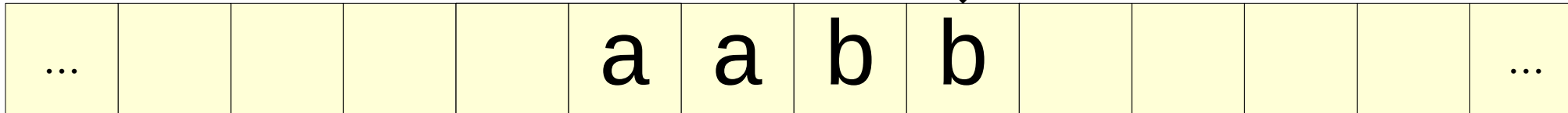
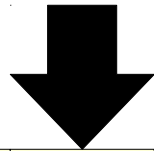

```
Start:  
  If Blank Return True  
  If 'b' Return False  
  Write Blank  
  
ZipRight:  
  Move Right  
  If Not Blank Goto ZipRight  
  Move Left  
  If Not 'b' Return False  
  Write Blank  
  
ZipLeft:  
  Move Left  
  If Not Blank Goto ZipLeft
```

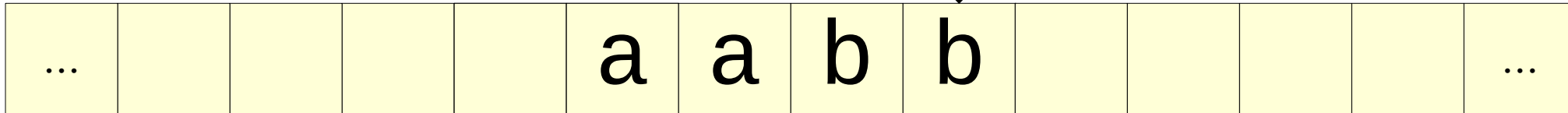
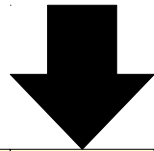

```
Start:  
  If Blank Return True  
  If 'b' Return False  
  Write Blank  
  
ZipRight:  
  Move Right  
  If Not Blank Goto ZipRight  
  Move Left  
  If Not 'b' Return False  
  Write Blank  
  
ZipLeft:  
  Move Left  
  If Not Blank Goto ZipLeft
```

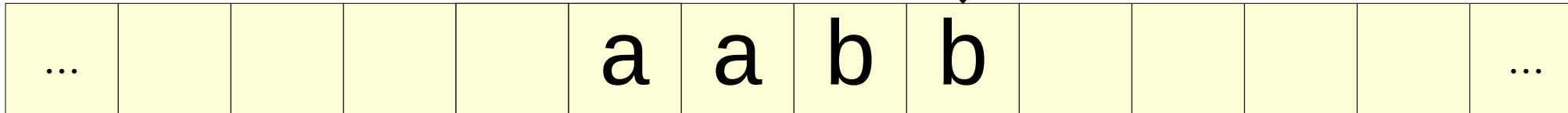
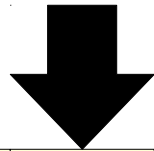

```
Start:  
  If Blank Return True  
  If 'b' Return False  
  Write Blank  
  
ZipRight:  
  Move Right  
  If Not Blank Goto ZipRight  
  Move Left  
  If Not 'b' Return False  
  Write Blank  
  
ZipLeft:  
  Move Left  
  If Not Blank Goto ZipLeft
```

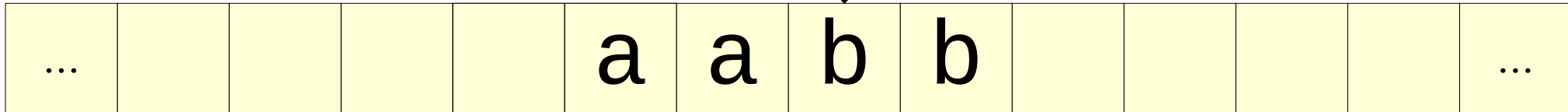
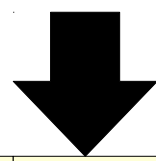

```
Start:  
  If Blank Return True  
  If 'b' Return False  
  Write Blank  
  
ZipRight:  
  Move Right  
  If Not Blank Goto ZipRight  
  Move Left  
  If Not 'b' Return False  
  Write Blank  
  
ZipLeft:  
  Move Left  
  If Not Blank Goto ZipLeft
```

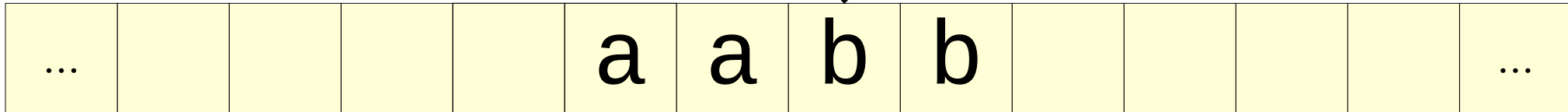
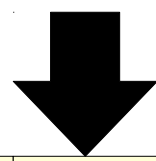

```
Start:  
  If Blank Return True  
  If 'b' Return False  
  Write Blank  
  
ZipRight:  
  Move Right  
  If Not Blank Goto ZipRight  
  Move Left  
  If Not 'b' Return False  
  Write Blank  
  
ZipLeft:  
  Move Left  
  If Not Blank Goto ZipLeft
```

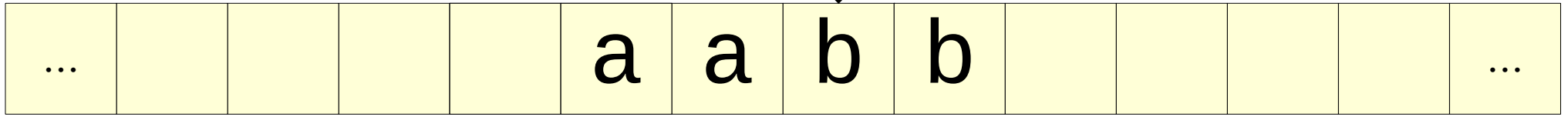
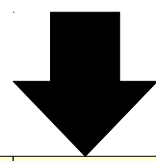

```
Start:  
  If Blank Return True  
  If 'b' Return False  
  Write Blank  
  
ZipRight:  
  Move Right  
  If Not Blank Goto ZipRight  
  Move Left  
  If Not 'b' Return False  
  Write Blank  
  
ZipLeft:  
  Move Left  
  If Not Blank Goto ZipLeft
```

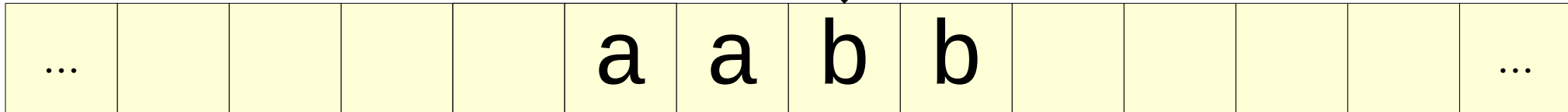
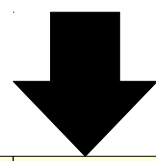

```
Start:  
  If Blank Return True  
  If 'b' Return False  
  Write Blank  
  
ZipRight:  
  Move Right  
  If Not Blank Goto ZipRight  
  Move Left  
  If Not 'b' Return False  
  Write Blank  
  
ZipLeft:  
  Move Left  
  If Not Blank Goto ZipLeft
```

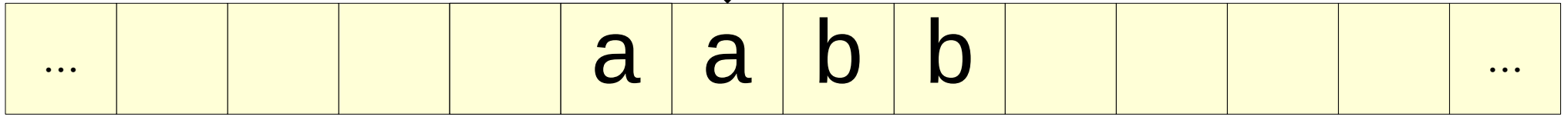
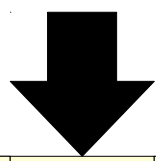

```
Start:  
  If Blank Return True  
  If 'b' Return False  
  Write Blank  
  
ZipRight:  
  Move Right  
  If Not Blank Goto ZipRight  
  Move Left  
  If Not 'b' Return False  
  Write Blank  
  
ZipLeft:  
  Move Left  
  If Not Blank Goto ZipLeft
```

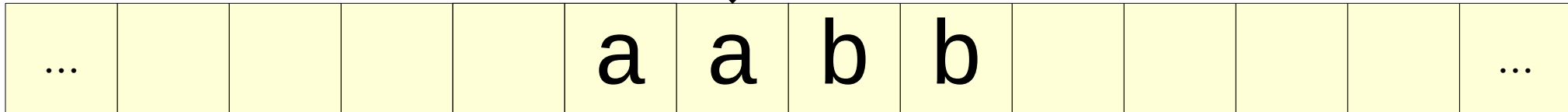
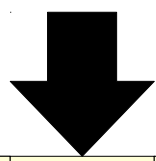

```
Start:  
  If Blank Return True  
  If 'b' Return False  
  Write Blank  
  
ZipRight:  
  Move Right  
  If Not Blank Goto ZipRight  
  Move Left  
  If Not 'b' Return False  
  Write Blank  
  
ZipLeft:  
  Move Left  
  If Not Blank Goto ZipLeft
```

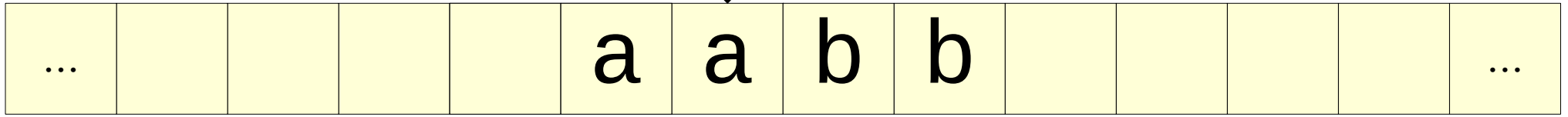
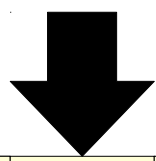

```
Start:  
  If Blank Return True  
  If 'b' Return False  
  Write Blank  
  
ZipRight:  
  Move Right  
  If Not Blank Goto ZipRight  
  Move Left  
  If Not 'b' Return False  
  Write Blank  
  
ZipLeft:  
  Move Left  
  If Not Blank Goto ZipLeft
```

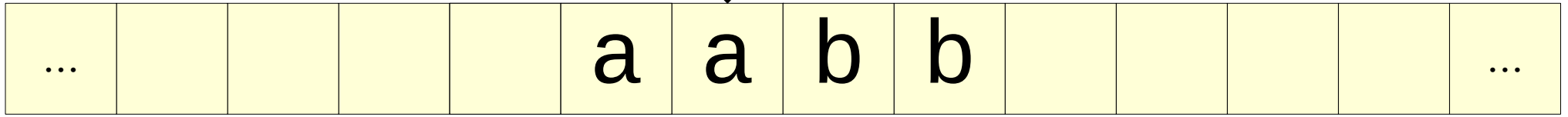
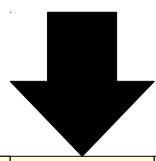

```
Start:  
  If Blank Return True  
  If 'b' Return False  
  Write Blank  
  
ZipRight:  
  Move Right  
  If Not Blank Goto ZipRight  
  Move Left  
  If Not 'b' Return False  
  Write Blank  
  
ZipLeft:  
  Move Left  
  If Not Blank Goto ZipLeft
```

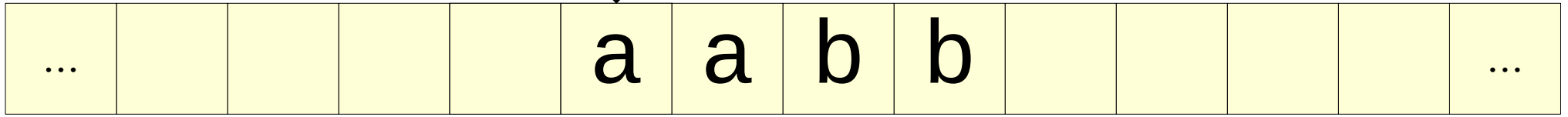
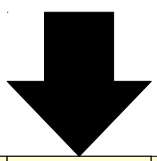

```
Start:  
  If Blank Return True  
  If 'b' Return False  
  Write Blank  
  
ZipRight:  
  Move Right  
  If Not Blank Goto ZipRight  
  Move Left  
  If Not 'b' Return False  
  Write Blank  
  
ZipLeft:  
  Move Left  
  If Not Blank Goto ZipLeft
```

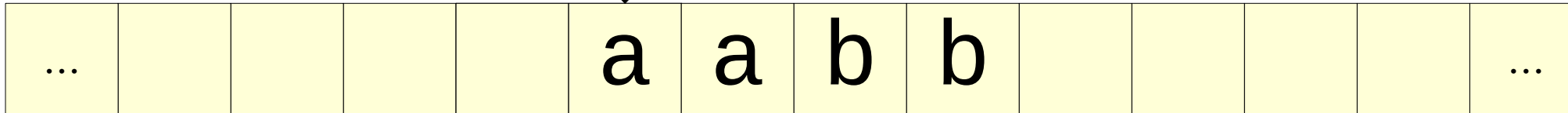
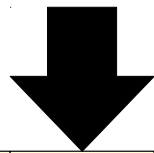

```
Start:  
  If Blank Return True  
  If 'b' Return False  
  Write Blank  
  
ZipRight:  
  Move Right  
  If Not Blank Goto ZipRight  
  Move Left  
  If Not 'b' Return False  
  Write Blank  
  
ZipLeft:  
  Move Left  
  If Not Blank Goto ZipLeft
```

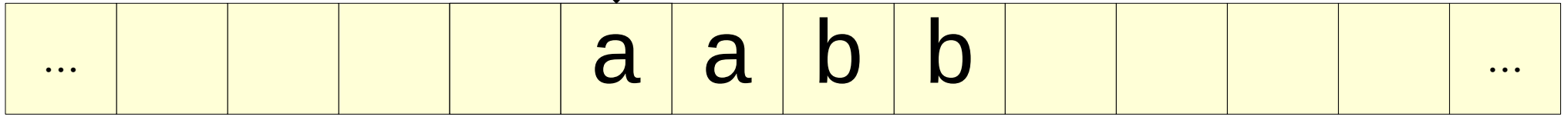
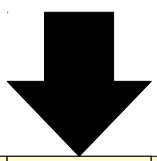

```
Start:  
  If Blank Return True  
  If 'b' Return False  
  Write Blank  
  
ZipRight:  
  Move Right  
  If Not Blank Goto ZipRight  
  Move Left  
  If Not 'b' Return False  
  Write Blank  
  
ZipLeft:  
  Move Left  
  If Not Blank Goto ZipLeft
```

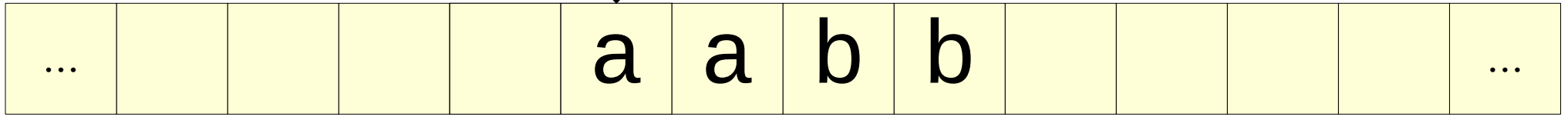
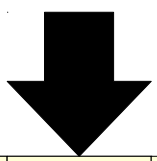

```
Start:  
  If Blank Return True  
  If 'b' Return False  
  Write Blank  
  
ZipRight:  
  Move Right  
  If Not Blank Goto ZipRight  
  Move Left  
  If Not 'b' Return False  
  Write Blank  
  
ZipLeft:  
  Move Left  
  If Not Blank Goto ZipLeft
```

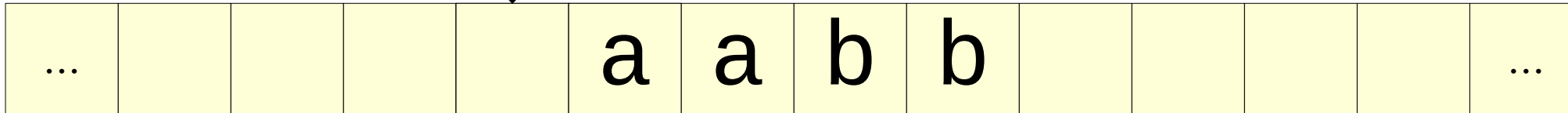
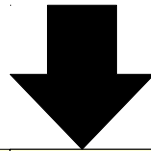

```
Start:  
  If Blank Return True  
  If 'b' Return False  
  Write Blank  
  
ZipRight:  
  Move Right  
  If Not Blank Goto ZipRight  
  Move Left  
  If Not 'b' Return False  
  Write Blank  
  
ZipLeft:  
  Move Left  
  If Not Blank Goto ZipLeft
```

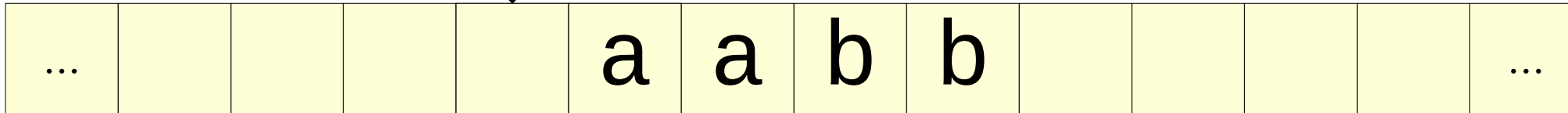
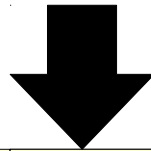

```
Start:  
  If Blank Return True  
  If 'b' Return False  
  Write Blank  
  
ZipRight:  
  Move Right  
  If Not Blank Goto ZipRight  
  Move Left  
  If Not 'b' Return False  
  Write Blank  
  
ZipLeft:  
  Move Left  
  If Not Blank Goto ZipLeft
```

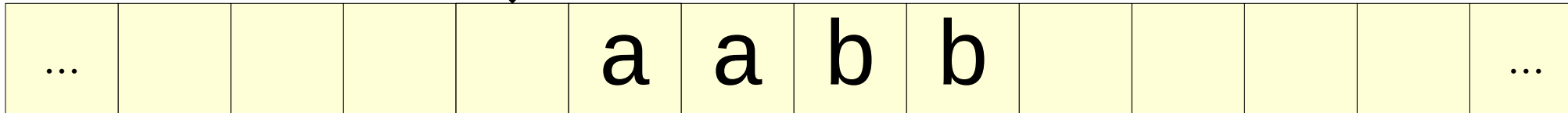
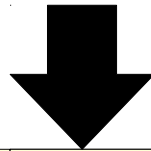

```
Start:  
  If Blank Return True  
  If 'b' Return False  
  Write Blank  
  
ZipRight:  
  Move Right  
  If Not Blank Goto ZipRight  
  Move Left  
  If Not 'b' Return False  
  Write Blank  
  
ZipLeft:  
  Move Left  
  If Not Blank Goto ZipLeft  
  Move Right
```

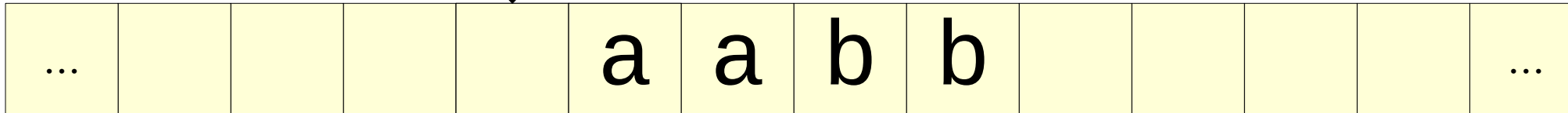
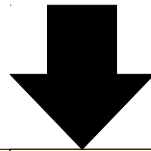

```
Start:  
  If Blank Return True  
  If 'b' Return False  
  Write Blank  
  
ZipRight:  
  Move Right  
  If Not Blank Goto ZipRight  
  Move Left  
  If Not 'b' Return False  
  Write Blank  
  
ZipLeft:  
  Move Left  
  If Not Blank Goto ZipLeft  
  Move Right
```

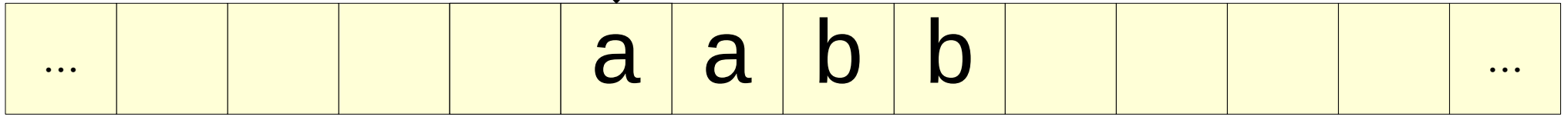
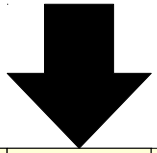

```
Start:  
  If Blank Return True  
  If 'b' Return False  
  Write Blank  
  
ZipRight:  
  Move Right  
  If Not Blank Goto ZipRight  
  Move Left  
  If Not 'b' Return False  
  Write Blank  
  
ZipLeft:  
  Move Left  
  If Not Blank Goto ZipLeft  
  Move Right
```

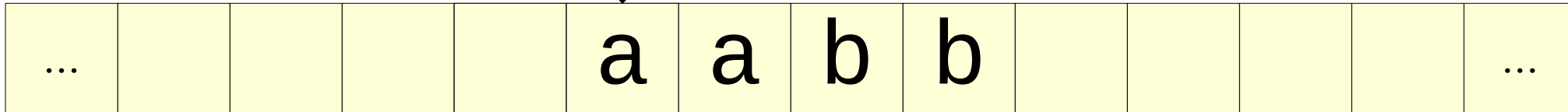
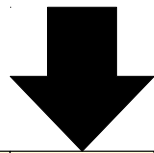

```
Start:  
  If Blank Return True  
  If 'b' Return False  
  Write Blank  
  
ZipRight:  
  Move Right  
  If Not Blank Goto ZipRight  
  Move Left  
  If Not 'b' Return False  
  Write Blank  
  
ZipLeft:  
  Move Left  
  If Not Blank Goto ZipLeft  
  Move Right  
  Goto Start
```

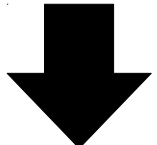

Start:

```
If Blank Return True  
If 'b' Return False  
Write Blank
```

ZipRight:

```
Move Right  
If Not Blank Goto ZipRight  
Move Left  
If Not 'b' Return False  
Write Blank
```

ZipLeft:

```
Move Left  
If Not Blank Goto ZipLeft  
Move Right  
Goto Start
```

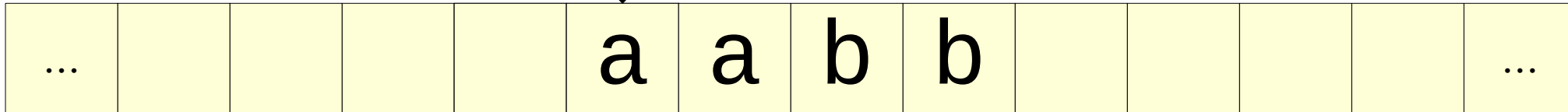
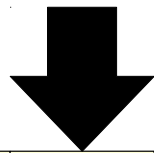

Start:

If Blank Return True

If 'b' Return False

Write Blank

ZipRight:

Move Right

If Not Blank Goto ZipRight

Move Left

If Not 'b' Return False

Write Blank

ZipLeft:

Move Left

If Not Blank Goto ZipLeft

Move Right

Goto Start

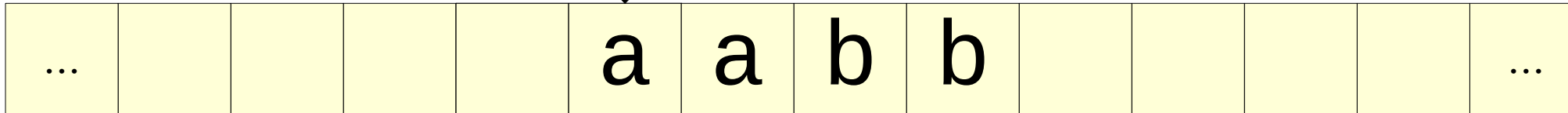
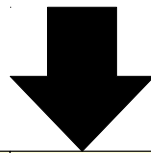

```
Start:  
  If Blank Return True  
  If 'b' Return False  
  Write Blank  
  
ZipRight:  
  Move Right  
  If Not Blank Goto ZipRight  
  Move Left  
  If Not 'b' Return False  
  Write Blank  
  
ZipLeft:  
  Move Left  
  If Not Blank Goto ZipLeft  
  Move Right  
  Goto Start
```

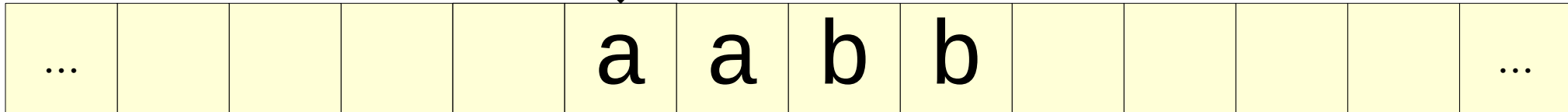
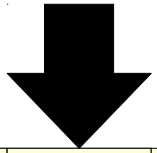

```
Start:  
  If Blank Return True  
  If 'b' Return False  
  Write Blank
```

```
ZipRight:  
  Move Right  
  If Not Blank Goto ZipRight  
  Move Left  
  If Not 'b' Return False  
  Write Blank
```

```
ZipLeft:  
  Move Left  
  If Not Blank Goto ZipLeft  
  Move Right  
  Goto Start
```

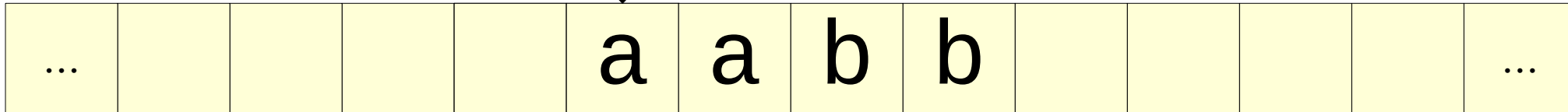
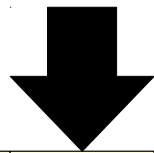

```
Start:  
  If Blank Return True  
  If 'b' Return False  
  Write Blank  
  
ZipRight:  
  Move Right  
  If Not Blank Goto ZipRight  
  Move Left  
  If Not 'b' Return False  
  Write Blank  
  
ZipLeft:  
  Move Left  
  If Not Blank Goto ZipLeft  
  Move Right  
  Goto Start
```

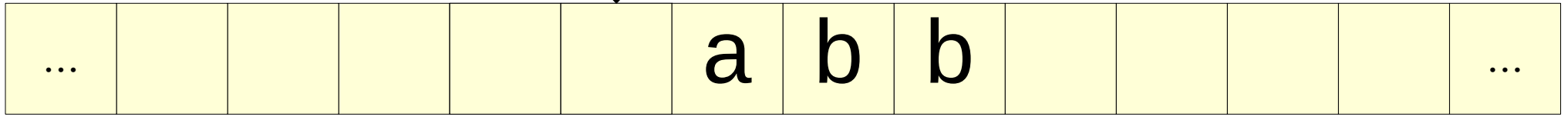
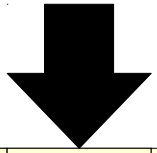

```
Start:  
  If Blank Return True  
  If 'b' Return False  
  Write Blank
```

```
ZipRight:
```

```
  Move Right  
  If Not Blank Goto ZipRight  
  Move Left  
  If Not 'b' Return False  
  Write Blank
```

```
ZipLeft:
```

```
  Move Left  
  If Not Blank Goto ZipLeft  
  Move Right  
  Goto Start
```

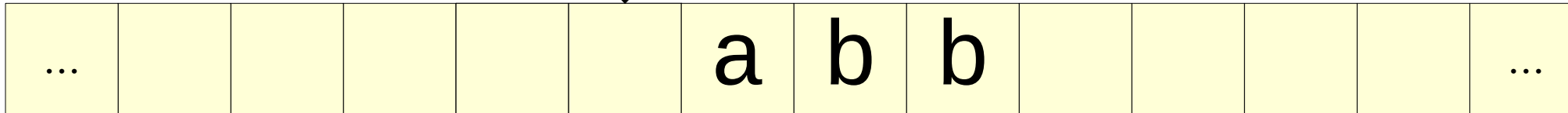
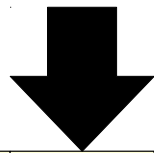

```
Start:  
  If Blank Return True  
  If 'b' Return False  
  Write Blank  
  
ZipRight:  
  Move Right  
  If Not Blank Goto ZipRight  
  Move Left  
  If Not 'b' Return False  
  Write Blank  
  
ZipLeft:  
  Move Left  
  If Not Blank Goto ZipLeft  
  Move Right  
  Goto Start
```

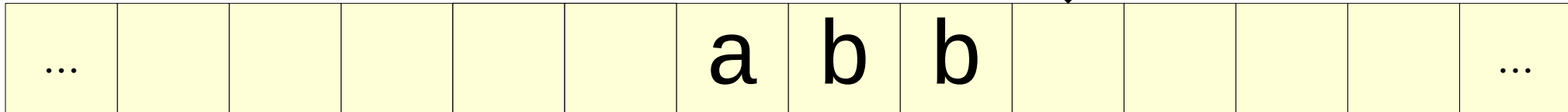
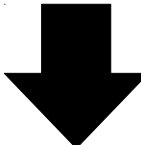

```
Start:  
  If Blank Return True  
  If 'b' Return False  
  Write Blank  
  
ZipRight:  
  Move Right  
  If Not Blank Goto ZipRight  
  Move Left  
  If Not 'b' Return False  
  Write Blank  
  
ZipLeft:  
  Move Left  
  If Not Blank Goto ZipLeft  
  Move Right  
  Goto Start
```

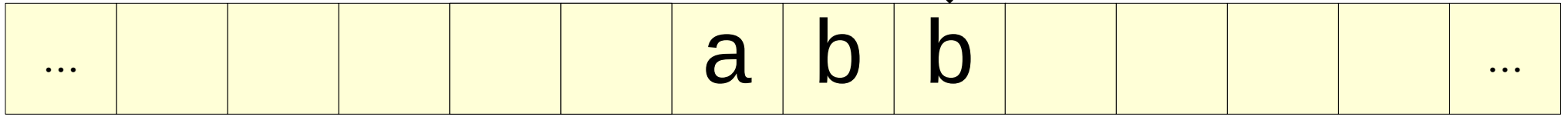
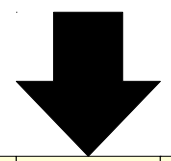

```
Start:  
  If Blank Return True  
  If 'b' Return False  
  Write Blank  
  
ZipRight:  
  Move Right  
  If Not Blank Goto ZipRight  
  Move Left  
  If Not 'b' Return False  
  Write Blank  
  
ZipLeft:  
  Move Left  
  If Not Blank Goto ZipLeft  
  Move Right  
  Goto Start
```

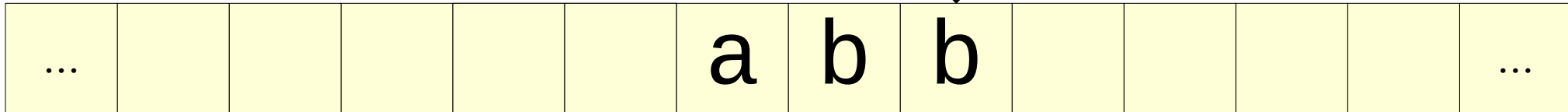
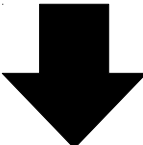

```
Start:  
  If Blank Return True  
  If 'b' Return False  
  Write Blank  
  
ZipRight:  
  Move Right  
  If Not Blank Goto ZipRight  
  Move Left  
  If Not 'b' Return False  
  Write Blank  
  
ZipLeft:  
  Move Left  
  If Not Blank Goto ZipLeft  
  Move Right  
  Goto Start
```

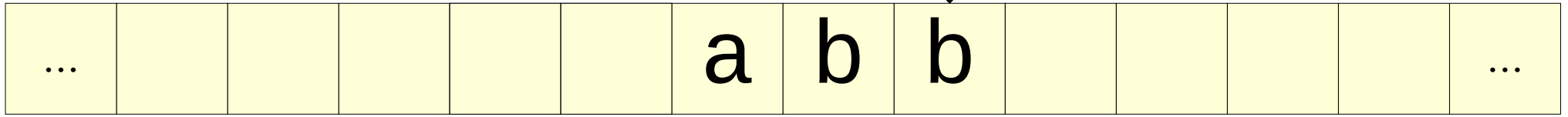
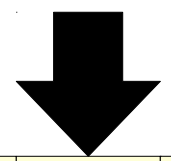

```
Start:  
  If Blank Return True  
  If 'b' Return False  
  Write Blank  
  
ZipRight:  
  Move Right  
  If Not Blank Goto ZipRight  
  Move Left  
  If Not 'b' Return False  
  Write Blank  
  
ZipLeft:  
  Move Left  
  If Not Blank Goto ZipLeft  
  Move Right  
  Goto Start
```

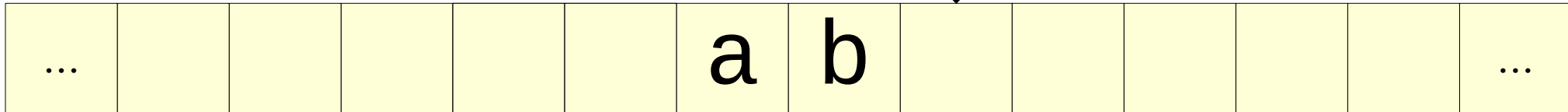
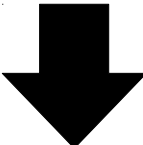

```
Start:  
  If Blank Return True  
  If 'b' Return False  
  Write Blank  
  
ZipRight:  
  Move Right  
  If Not Blank Goto ZipRight  
  Move Left  
  If Not 'b' Return False  
  Write Blank  
  
ZipLeft:  
  Move Left  
  If Not Blank Goto ZipLeft  
  Move Right  
  Goto Start
```

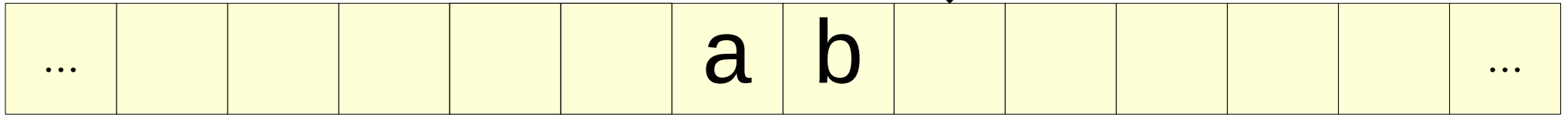
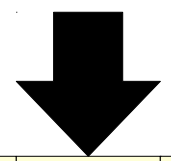

```
Start:  
  If Blank Return True  
  If 'b' Return False  
  Write Blank  
  
ZipRight:  
  Move Right  
  If Not Blank Goto ZipRight  
  Move Left  
  If Not 'b' Return False  
  Write Blank  
  
ZipLeft:  
  Move Left  
  If Not Blank Goto ZipLeft  
  Move Right  
  Goto Start
```

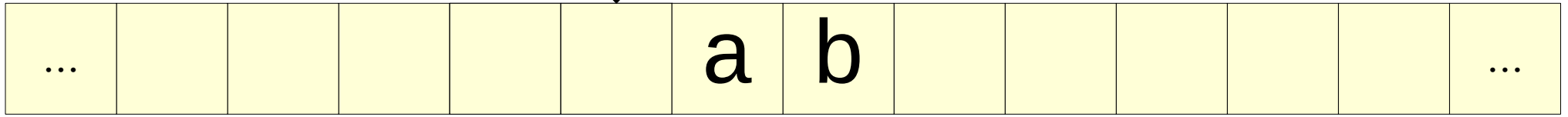
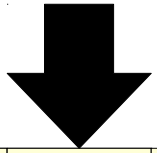

```
Start:  
  If Blank Return True  
  If 'b' Return False  
  Write Blank  
  
ZipRight:  
  Move Right  
  If Not Blank Goto ZipRight  
  Move Left  
  If Not 'b' Return False  
  Write Blank  
  
ZipLeft:  
  Move Left  
  If Not Blank Goto ZipLeft  
  Move Right  
  Goto Start
```

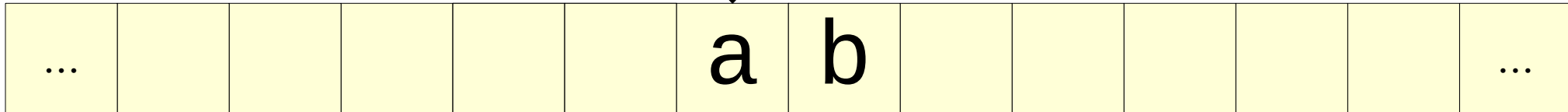
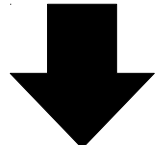

```
Start:  
  If Blank Return True  
  If 'b' Return False  
  Write Blank  
  
ZipRight:  
  Move Right  
  If Not Blank Goto ZipRight  
  Move Left  
  If Not 'b' Return False  
  Write Blank  
  
ZipLeft:  
  Move Left  
  If Not Blank Goto ZipLeft  
  Move Right  
  Goto Start
```

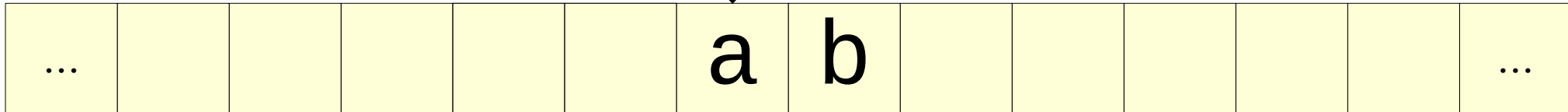
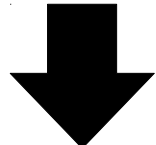

Start:

```
If Blank Return True  
If 'b' Return False  
Write Blank
```

ZipRight:

```
Move Right  
If Not Blank Goto ZipRight  
Move Left  
If Not 'b' Return False  
Write Blank
```

ZipLeft:

```
Move Left  
If Not Blank Goto ZipLeft  
Move Right  
Goto Start
```

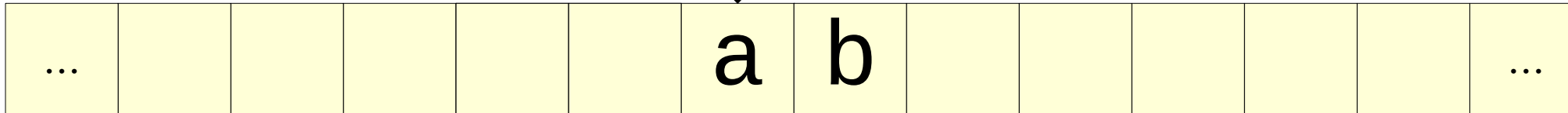
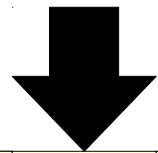

Start:

If Blank Return True

If 'b' Return False

Write Blank

ZipRight:

Move Right

If Not Blank Goto ZipRight

Move Left

If Not 'b' Return False

Write Blank

ZipLeft:

Move Left

If Not Blank Goto ZipLeft

Move Right

Goto Start

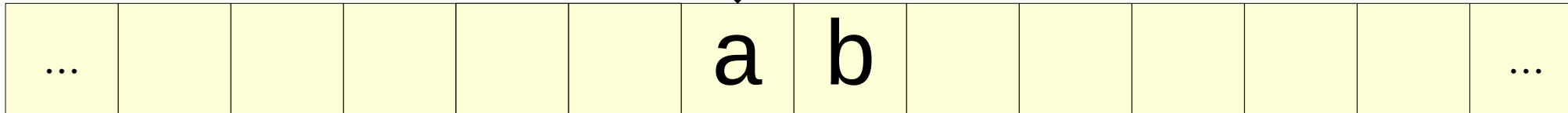
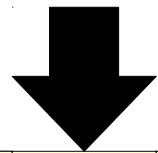

```
Start:  
  If Blank Return True  
  If 'b' Return False  
  Write Blank  
  
ZipRight:  
  Move Right  
  If Not Blank Goto ZipRight  
  Move Left  
  If Not 'b' Return False  
  Write Blank  
  
ZipLeft:  
  Move Left  
  If Not Blank Goto ZipLeft  
  Move Right  
  Goto Start
```

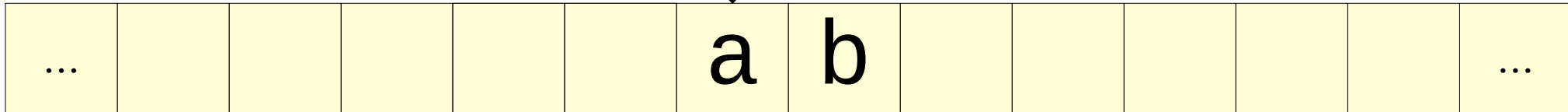
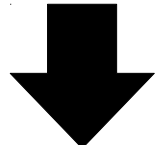

```
Start:  
  If Blank Return True  
  If 'b' Return False  
  Write Blank  
  
ZipRight:  
  Move Right  
  If Not Blank Goto ZipRight  
  Move Left  
  If Not 'b' Return False  
  Write Blank  
  
ZipLeft:  
  Move Left  
  If Not Blank Goto ZipLeft  
  Move Right  
  Goto Start
```

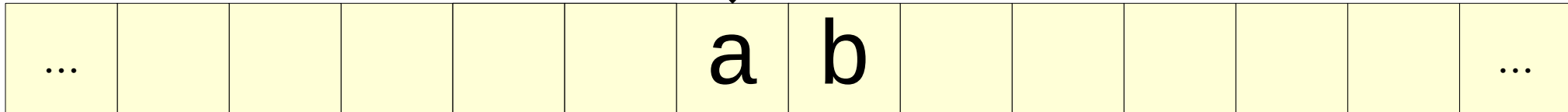
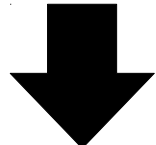

```
Start:  
  If Blank Return True  
  If 'b' Return False  
  Write Blank  
  
ZipRight:  
  Move Right  
  If Not Blank Goto ZipRight  
  Move Left  
  If Not 'b' Return False  
  Write Blank  
  
ZipLeft:  
  Move Left  
  If Not Blank Goto ZipLeft  
  Move Right  
  Goto Start
```

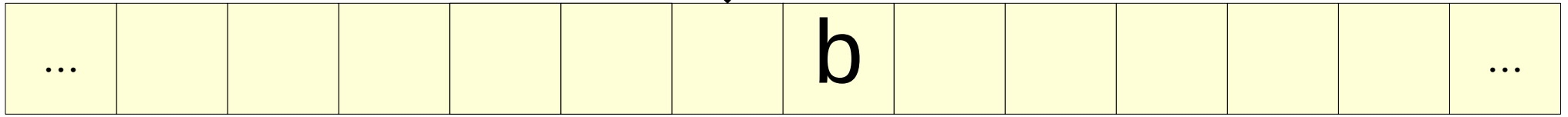
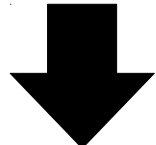

```
Start:  
  If Blank Return True  
  If 'b' Return False  
  Write Blank
```

```
ZipRight:
```

```
  Move Right  
  If Not Blank Goto ZipRight  
  Move Left  
  If Not 'b' Return False  
  Write Blank
```

```
ZipLeft:
```

```
  Move Left  
  If Not Blank Goto ZipLeft  
  Move Right  
  Goto Start
```

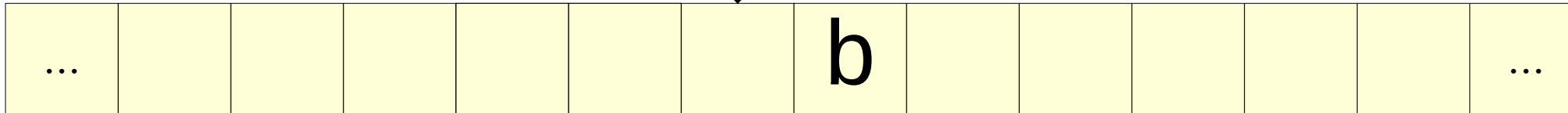
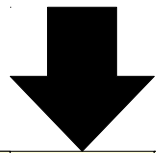

```
Start:  
  If Blank Return True  
  If 'b' Return False  
  Write Blank  
  
ZipRight:  
  Move Right  
  If Not Blank Goto ZipRight  
  Move Left  
  If Not 'b' Return False  
  Write Blank  
  
ZipLeft:  
  Move Left  
  If Not Blank Goto ZipLeft  
  Move Right  
  Goto Start
```

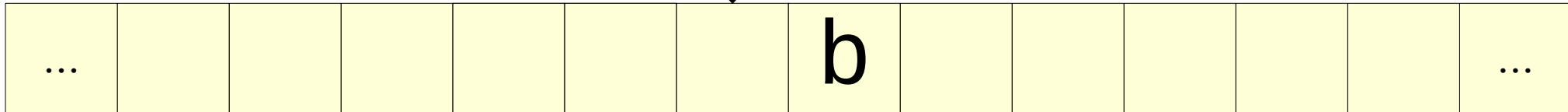
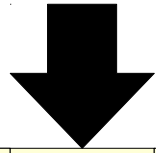

```
Start:  
  If Blank Return True  
  If 'b' Return False  
  Write Blank  
  
ZipRight:  
  Move Right  
  If Not Blank Goto ZipRight  
  Move Left  
  If Not 'b' Return False  
  Write Blank  
  
ZipLeft:  
  Move Left  
  If Not Blank Goto ZipLeft  
  Move Right  
  Goto Start
```

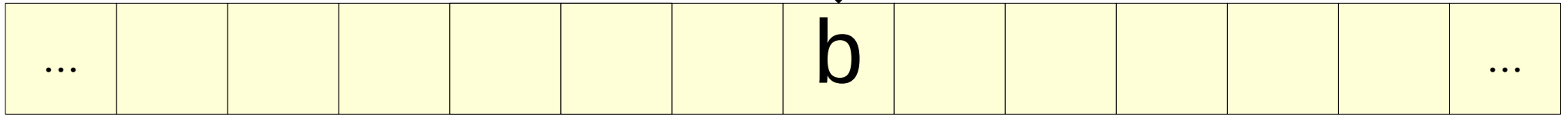
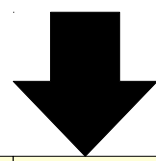

```
Start:  
  If Blank Return True  
  If 'b' Return False  
  Write Blank  
  
ZipRight:  
  Move Right  
  If Not Blank Goto ZipRight  
  Move Left  
  If Not 'b' Return False  
  Write Blank  
  
ZipLeft:  
  Move Left  
  If Not Blank Goto ZipLeft  
  Move Right  
  Goto Start
```

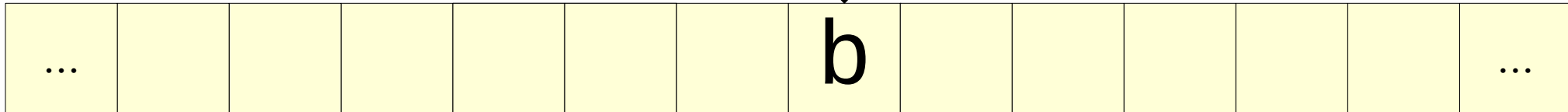
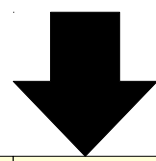

```
Start:  
  If Blank Return True  
  If 'b' Return False  
  Write Blank
```

ZipRight:

```
Move Right  
If Not Blank Goto ZipRight  
Move Left  
If Not 'b' Return False  
Write Blank
```

ZipLeft:

```
Move Left  
If Not Blank Goto ZipLeft  
Move Right  
Goto Start
```

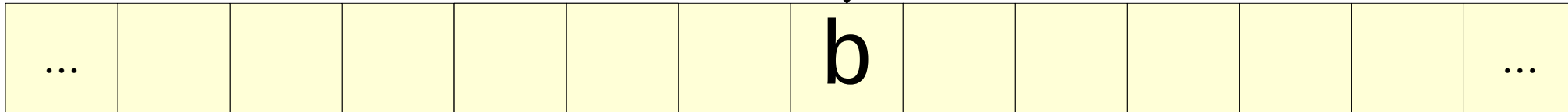
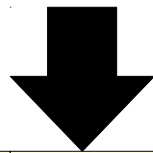

```
Start:  
  If Blank Return True  
  If 'b' Return False  
  Write Blank  
  
ZipRight:  
  Move Right  
  If Not Blank Goto ZipRight  
  Move Left  
  If Not 'b' Return False  
  Write Blank  
  
ZipLeft:  
  Move Left  
  If Not Blank Goto ZipLeft  
  Move Right  
  Goto Start
```

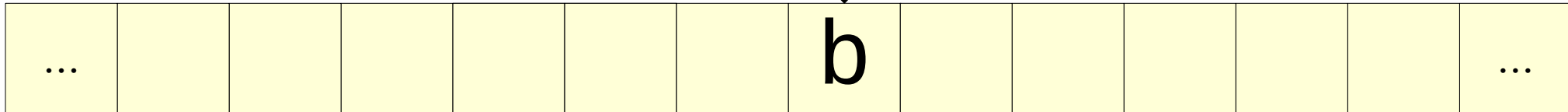
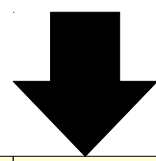

```
Start:  
  If Blank Return True  
  If 'b' Return False  
  Write Blank  
  
ZipRight:  
  Move Right  
  If Not Blank Goto ZipRight  
  Move Left  
  If Not 'b' Return False  
  Write Blank  
  
ZipLeft:  
  Move Left  
  If Not Blank Goto ZipLeft  
  Move Right  
  Goto Start
```

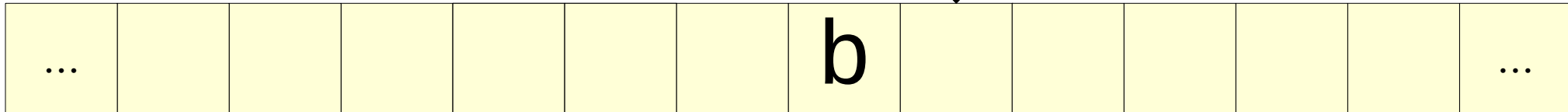
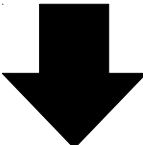

```
Start:  
  If Blank Return True  
  If 'b' Return False  
  Write Blank  
  
ZipRight:  
  Move Right  
  If Not Blank Goto ZipRight  
  Move Left  
  If Not 'b' Return False  
  Write Blank  
  
ZipLeft:  
  Move Left  
  If Not Blank Goto ZipLeft  
  Move Right  
  Goto Start
```

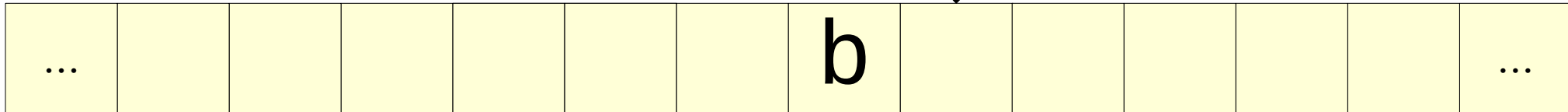
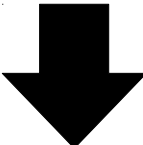

```
Start:  
  If Blank Return True  
  If 'b' Return False  
  Write Blank  
  
ZipRight:  
  Move Right  
  If Not Blank Goto ZipRight  
  Move Left  
  If Not 'b' Return False  
  Write Blank  
  
ZipLeft:  
  Move Left  
  If Not Blank Goto ZipLeft  
  Move Right  
  Goto Start
```

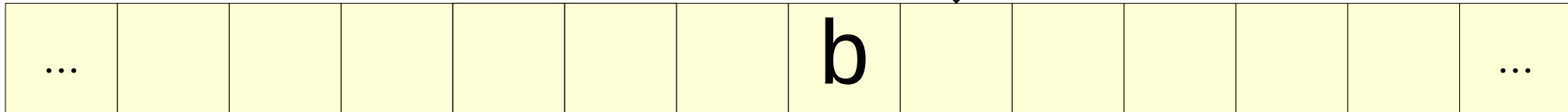
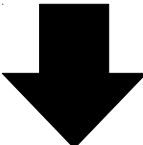

```
Start:  
  If Blank Return True  
  If 'b' Return False  
  Write Blank  
  
ZipRight:  
  Move Right  
  If Not Blank Goto ZipRight  
  Move Left  
  If Not 'b' Return False  
  Write Blank  
  
ZipLeft:  
  Move Left  
  If Not Blank Goto ZipLeft  
  Move Right  
  Goto Start
```

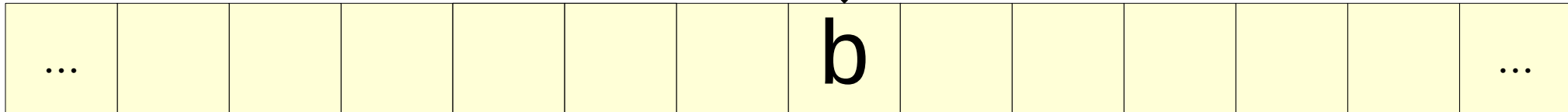
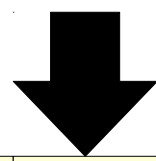

```
Start:  
  If Blank Return True  
  If 'b' Return False  
  Write Blank  
  
ZipRight:  
  Move Right  
  If Not Blank Goto ZipRight  
  Move Left  
  If Not 'b' Return False  
  Write Blank  
  
ZipLeft:  
  Move Left  
  If Not Blank Goto ZipLeft  
  Move Right  
  Goto Start
```

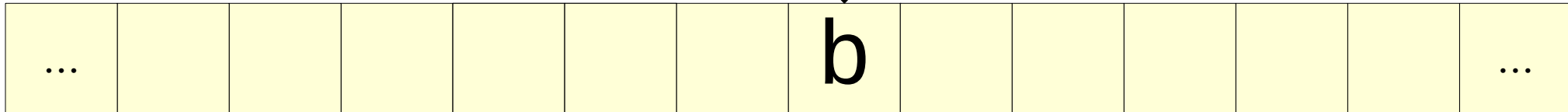
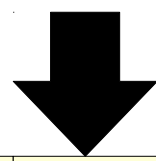

```
Start:  
  If Blank Return True  
  If 'b' Return False  
  Write Blank  
  
ZipRight:  
  Move Right  
  If Not Blank Goto ZipRight  
  Move Left  
  If Not 'b' Return False  
  Write Blank  
  
ZipLeft:  
  Move Left  
  If Not Blank Goto ZipLeft  
  Move Right  
  Goto Start
```

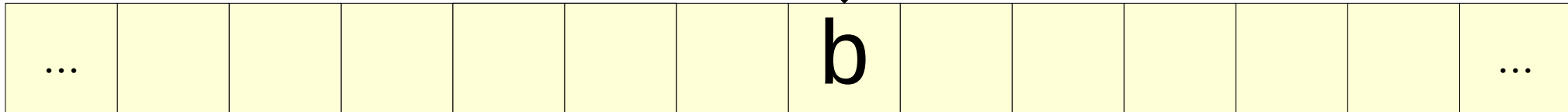
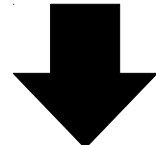

```
Start:  
  If Blank Return True  
  If 'b' Return False  
  Write Blank  
  
ZipRight:  
  Move Right  
  If Not Blank Goto ZipRight  
  Move Left  
  If Not 'b' Return False  
  Write Blank  
  
ZipLeft:  
  Move Left  
  If Not Blank Goto ZipLeft  
  Move Right  
  Goto Start
```

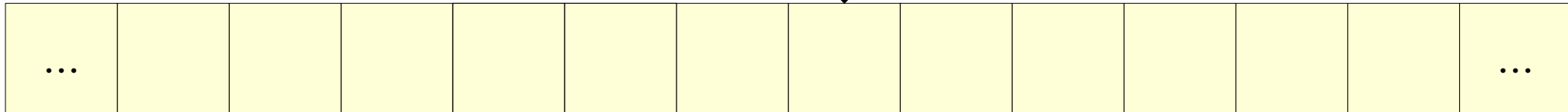
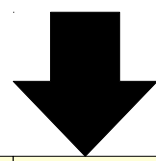

```
Start:  
  If Blank Return True  
  If 'b' Return False  
  Write Blank  
  
ZipRight:  
  Move Right  
  If Not Blank Goto ZipRight  
  Move Left  
  If Not 'b' Return False  
  Write Blank  
  
ZipLeft:  
  Move Left  
  If Not Blank Goto ZipLeft  
  Move Right  
  Goto Start
```

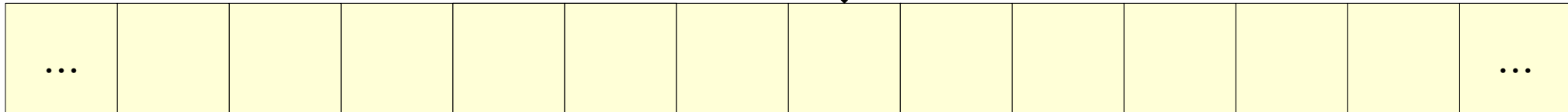
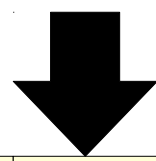

```
Start:  
  If Blank Return True  
  If 'b' Return False  
  Write Blank  
  
ZipRight:  
  Move Right  
  If Not Blank Goto ZipRight  
  Move Left  
  If Not 'b' Return False  
  Write Blank  
  
ZipLeft:  
  Move Left  
  If Not Blank Goto ZipLeft  
  Move Right  
  Goto Start
```

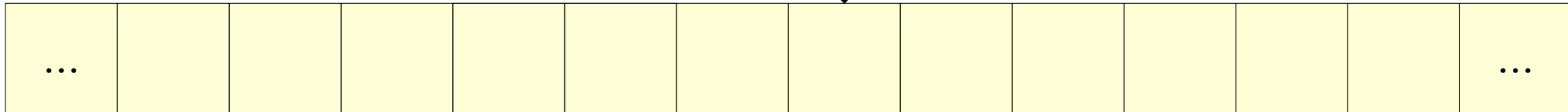
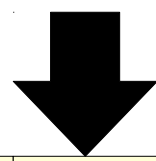

```
Start:  
  If Blank Return True  
  If 'b' Return False  
  Write Blank  
  
ZipRight:  
  Move Right  
  If Not Blank Goto ZipRight  
  Move Left  
  If Not 'b' Return False  
  Write Blank  
  
ZipLeft:  
  Move Left  
  If Not Blank Goto ZipLeft  
  Move Right  
  Goto Start
```

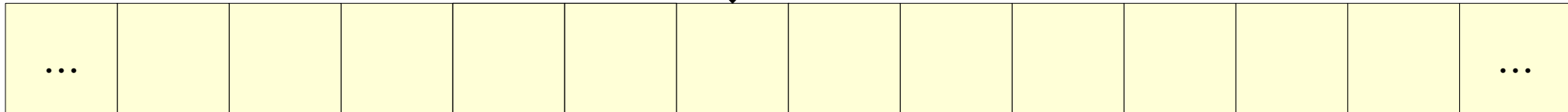
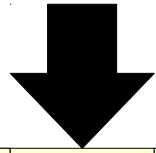

```
Start:  
  If Blank Return True  
  If 'b' Return False  
  Write Blank  
  
ZipRight:  
  Move Right  
  If Not Blank Goto ZipRight  
  Move Left  
  If Not 'b' Return False  
  Write Blank  
  
ZipLeft:  
  Move Left  
  If Not Blank Goto ZipLeft  
  Move Right  
  Goto Start
```

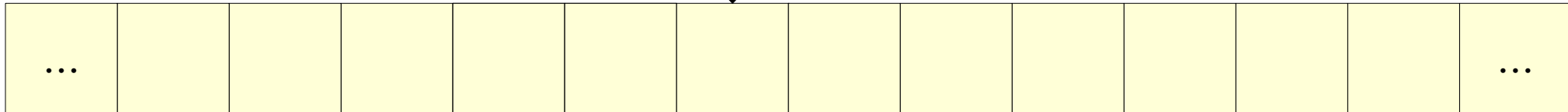
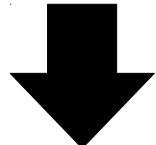

```
Start:  
  If Blank Return True  
  If 'b' Return False  
  Write Blank  
  
ZipRight:  
  Move Right  
  If Not Blank Goto ZipRight  
  Move Left  
  If Not 'b' Return False  
  Write Blank  
  
ZipLeft:  
  Move Left  
  If Not Blank Goto ZipLeft  
  Move Right  
  Goto Start
```

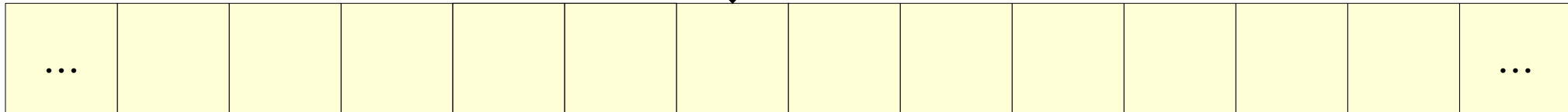
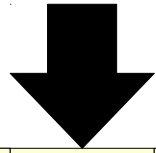

```
Start:  
  If Blank Return True  
  If 'b' Return False  
  Write Blank  
  
ZipRight:  
  Move Right  
  If Not Blank Goto ZipRight  
  Move Left  
  If Not 'b' Return False  
  Write Blank  
  
ZipLeft:  
  Move Left  
  If Not Blank Goto ZipLeft  
  Move Right  
  Goto Start
```

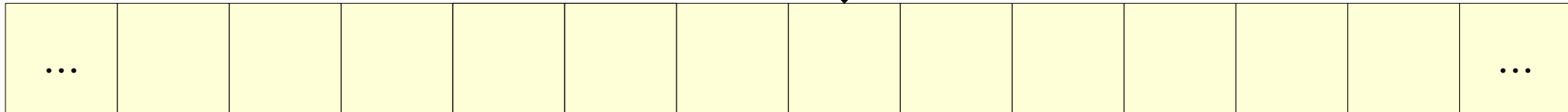
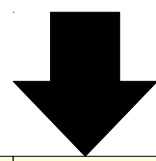

```
Start:  
  If Blank Return True  
  If 'b' Return False  
  Write Blank  
  
ZipRight:  
  Move Right  
  If Not Blank Goto ZipRight  
  Move Left  
  If Not 'b' Return False  
  Write Blank  
  
ZipLeft:  
  Move Left  
  If Not Blank Goto ZipLeft  
  Move Right  
  Goto Start
```

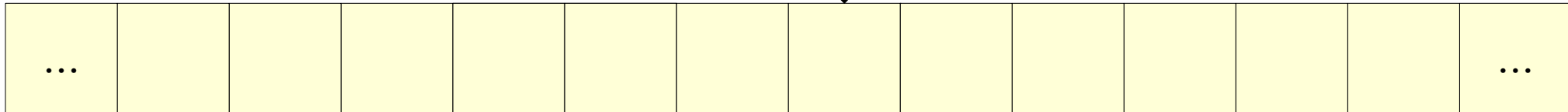
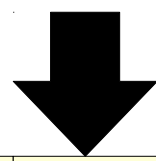

Start:

```
If Blank Return True  
If 'b' Return False  
Write Blank
```

ZipRight:

```
Move Right  
If Not Blank Goto ZipRight  
Move Left  
If Not 'b' Return False  
Write Blank
```

ZipLeft:

```
Move Left  
If Not Blank Goto ZipLeft  
Move Right  
Goto Start
```

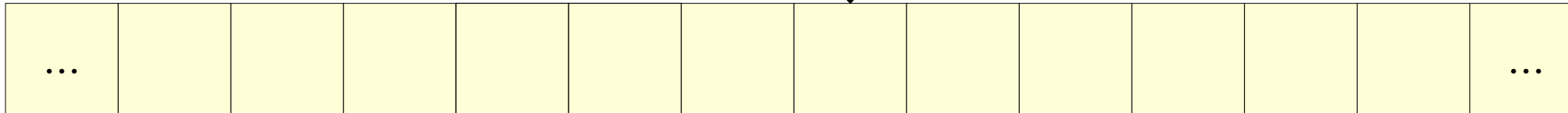
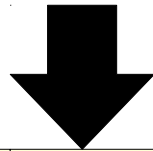

Start:

If Blank Return True

If 'b' Return False

Write Blank

ZipRight:

Move Right

If Not Blank Goto ZipRight

Move Left

If Not 'b' Return False

Write Blank

ZipLeft:

Move Left

If Not Blank Goto ZipLeft

Move Right

Goto Start

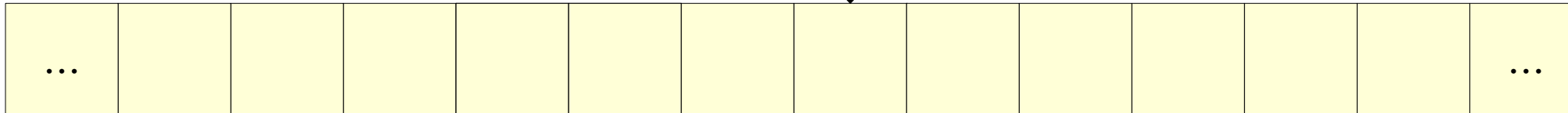
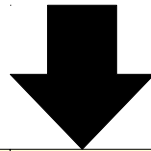

Start:

If Blank Return True 😊

If 'b' Return False

Write Blank

ZipRight:

Move Right

If Not Blank Goto ZipRight

Move Left

If Not 'b' Return False

Write Blank

ZipLeft:

Move Left

If Not Blank Goto ZipLeft

Move Right

Goto Start

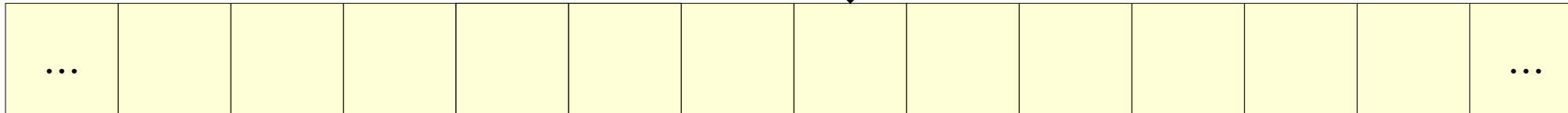
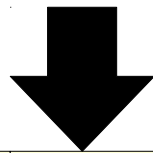

Where We are Headed: TMs are Equivalent to Modern Programming Languages!

- More on this next time, but for this to be true we need to convince ourselves that TMs can do things like:
 - Loops
 - Variables
 - Function calls

Our Next Challenge

- Let's now take aim at this more general language:

$$\{ w \in \{\mathbf{a}, \mathbf{b}\}^* \mid w \text{ has an equal number of } \mathbf{a}'\text{s and } \mathbf{b}'\text{s} \}$$

- This language is not regular (do you see why?)
- It is context-free, but it's a bit tricky to write a CFG for it. (This is a great exercise!)
- Let's see how to design a TM for it.

A Caveat

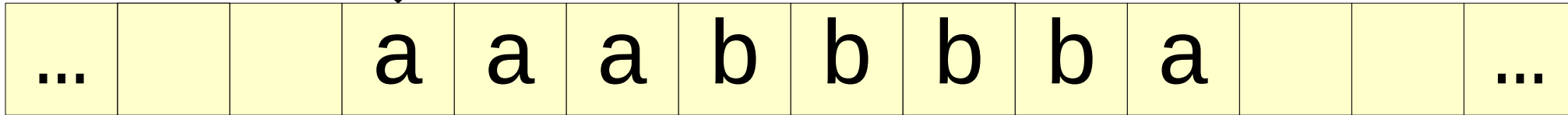
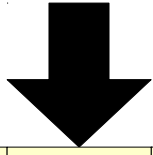

A Caveat

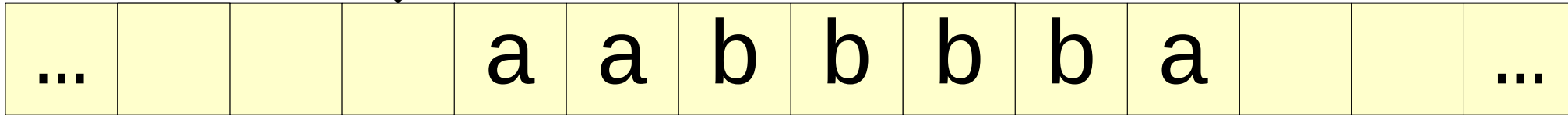
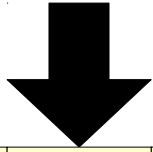

A Caveat

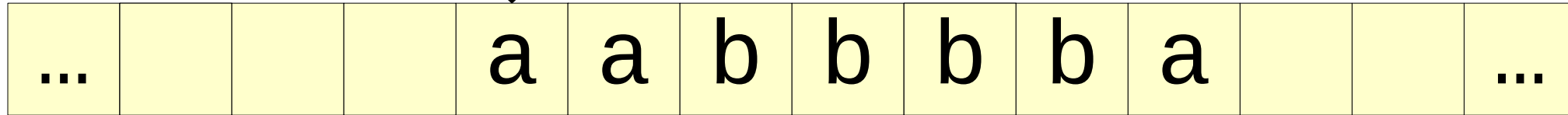
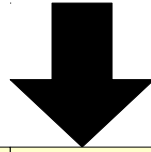

A Caveat

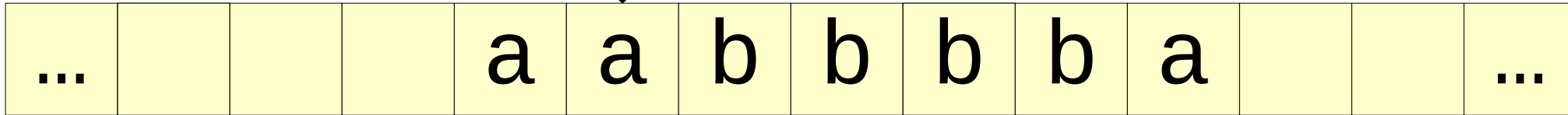
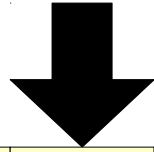

A Caveat

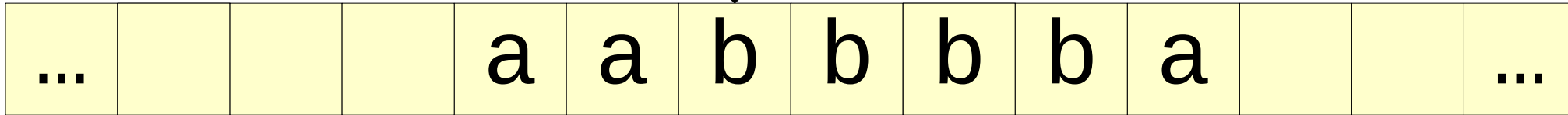
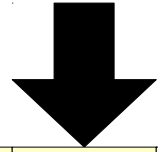

A Caveat

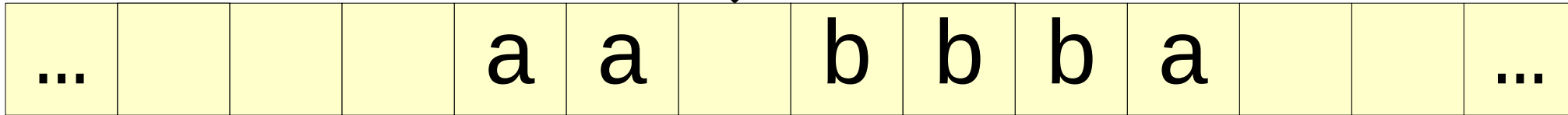
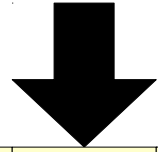

A Caveat

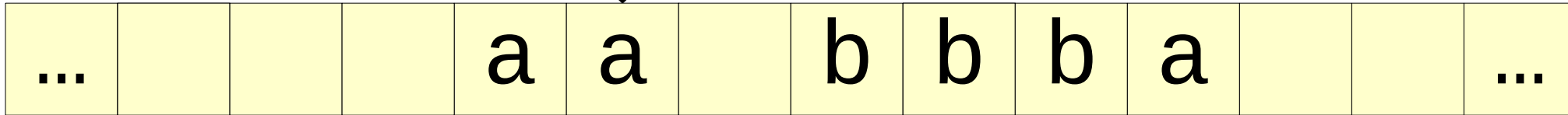
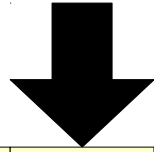

A Caveat

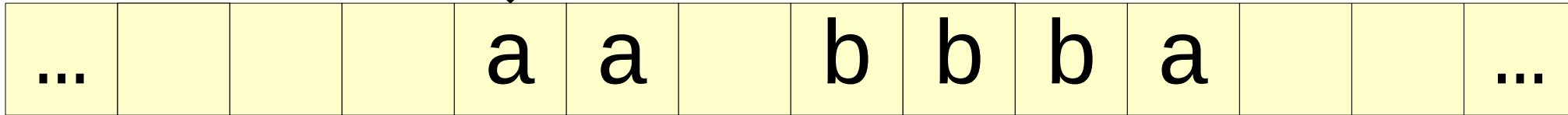
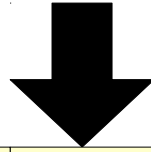

A Caveat

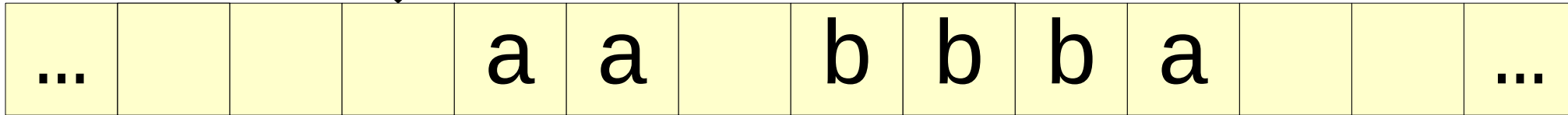
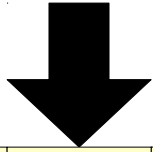

A Caveat

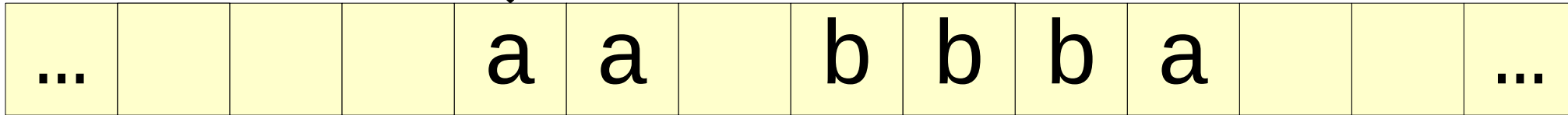
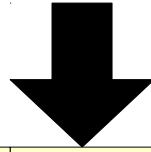

A Caveat

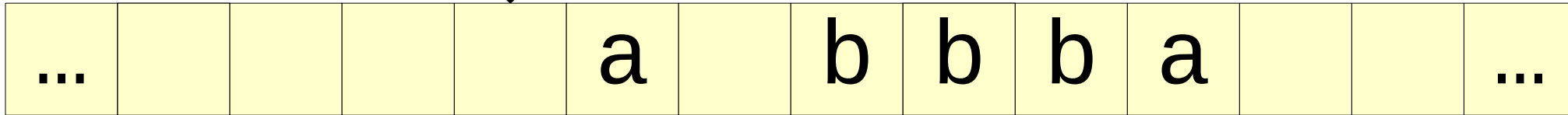
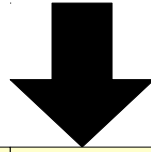

A Caveat

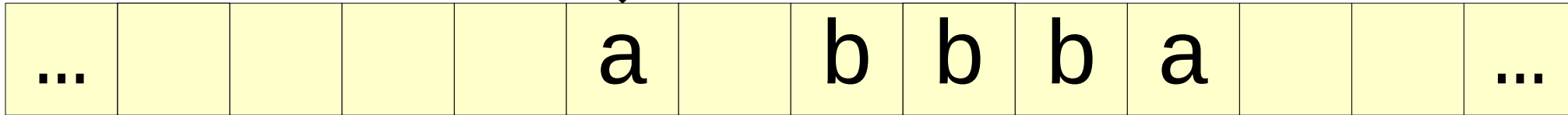
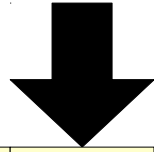

A Caveat

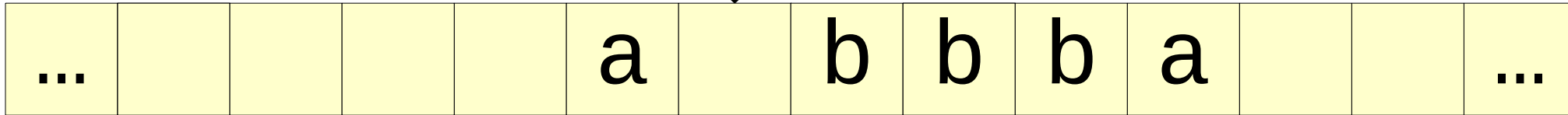
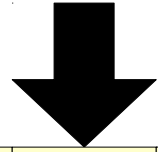

A Caveat

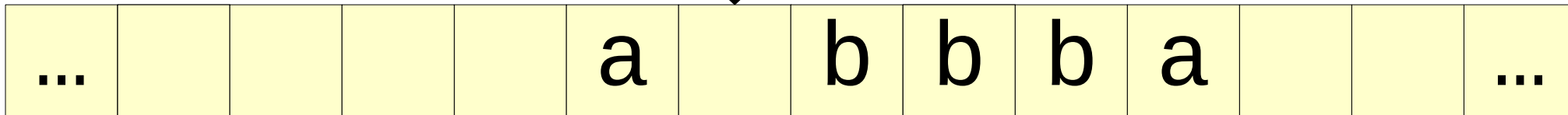
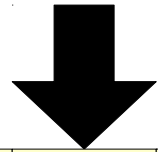

How do we know that
this blank isn't one of
the infinitely many
blanks after our input
string?

A Caveat

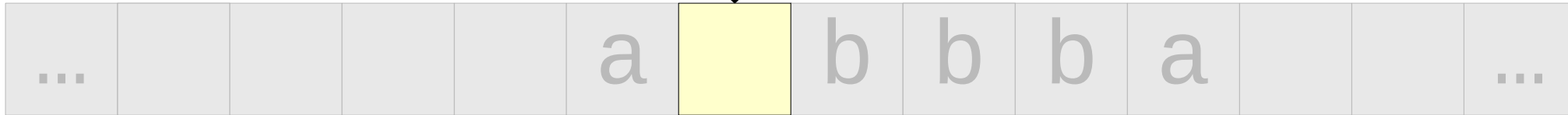
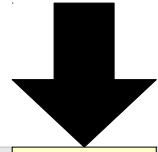

How do we know that
this blank isn't one of
the infinitely many
blanks after our input
string?

A Caveat

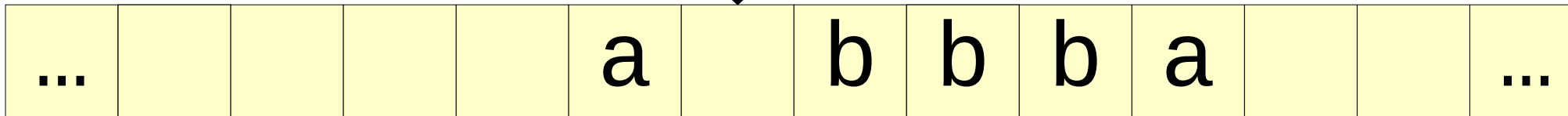
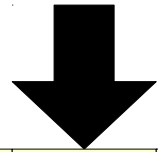

How do we know that
this blank isn't one of
the infinitely many
blanks after our input
string?

A Caveat

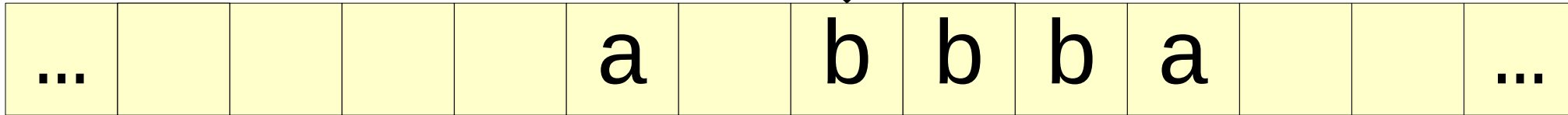
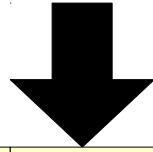

A Caveat

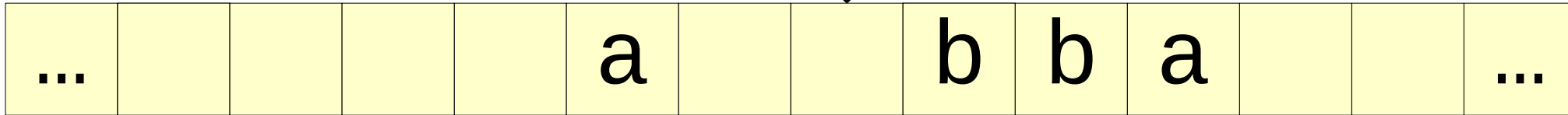
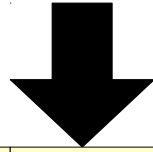

A Caveat

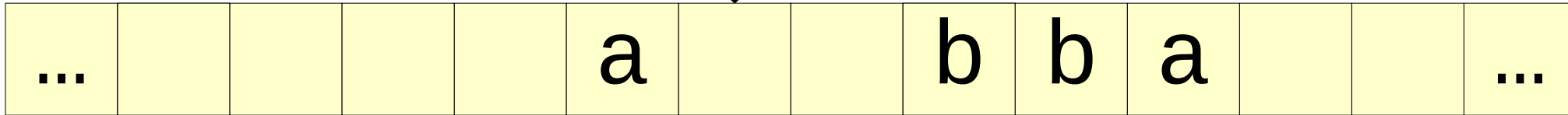
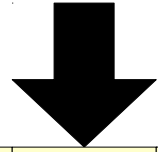

A Caveat

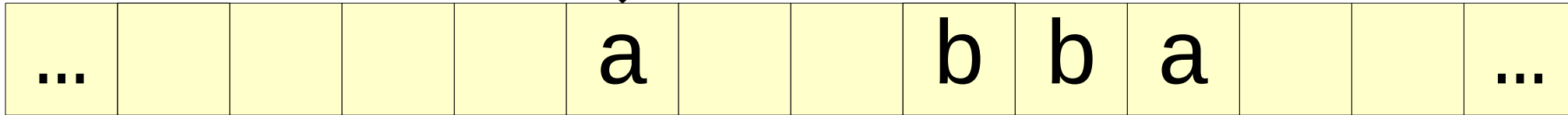
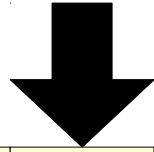

A Caveat

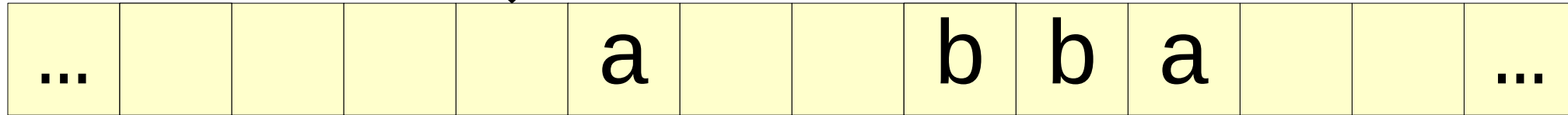
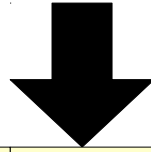

A Caveat

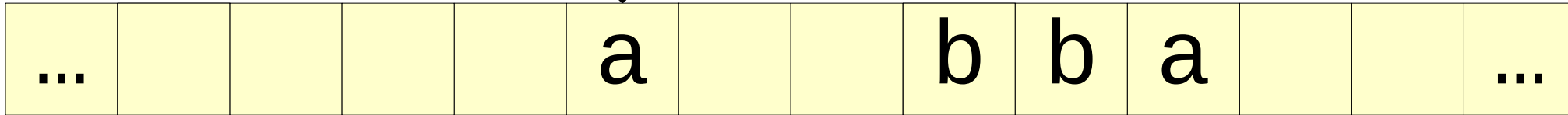
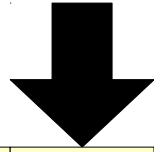

A Caveat

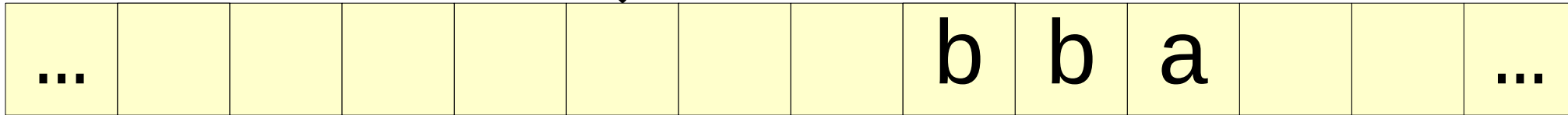
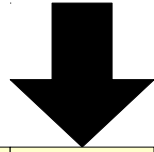

A Caveat

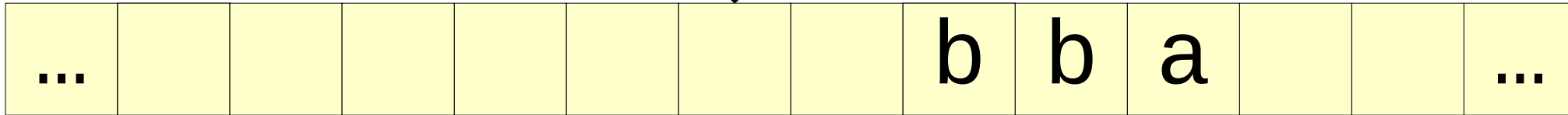
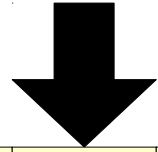

A Caveat

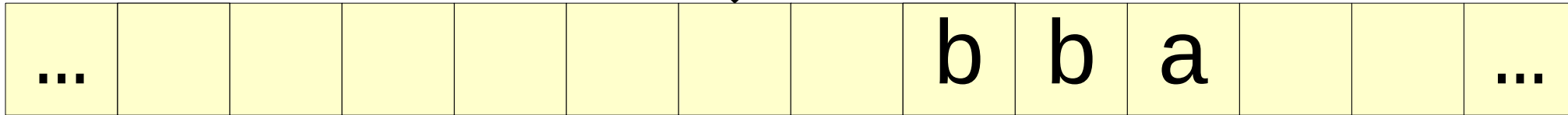
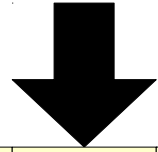

How do we know that
this blank isn't one of
the infinitely many
blanks after our input
string?

A Caveat

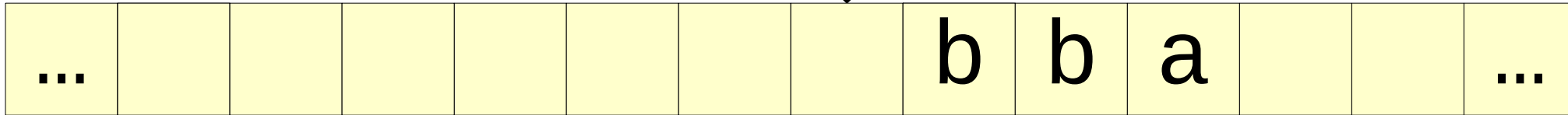
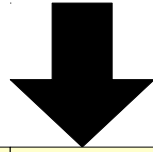

A Caveat

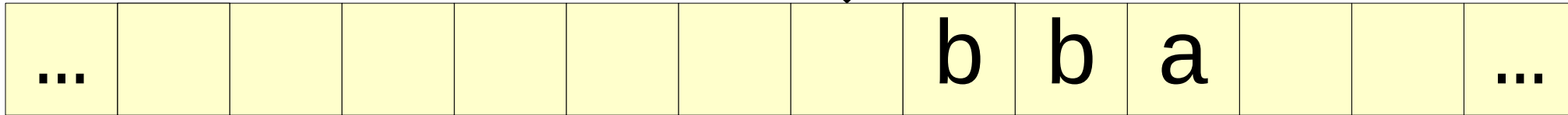
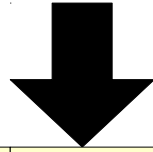

How do we know that this blank isn't one of the infinitely many blanks after our input string?

One Solution

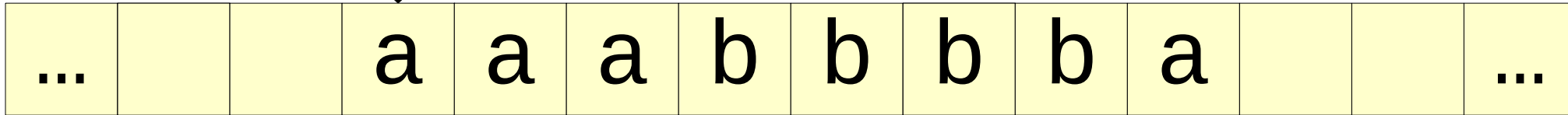
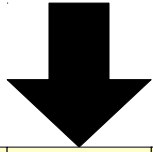

One Solution

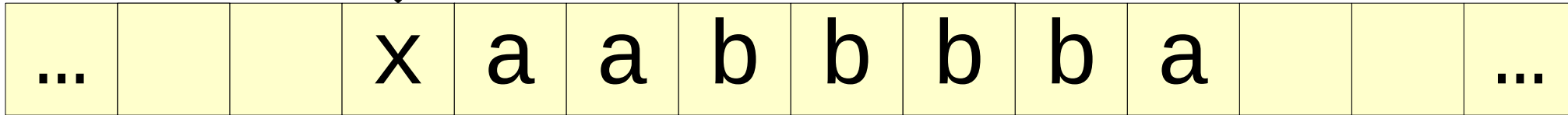
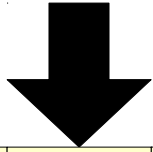

One Solution

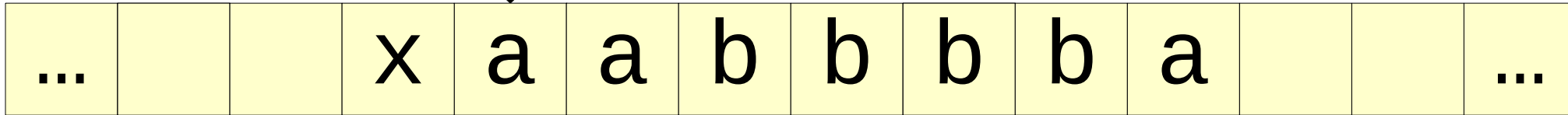
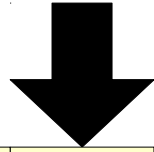

One Solution

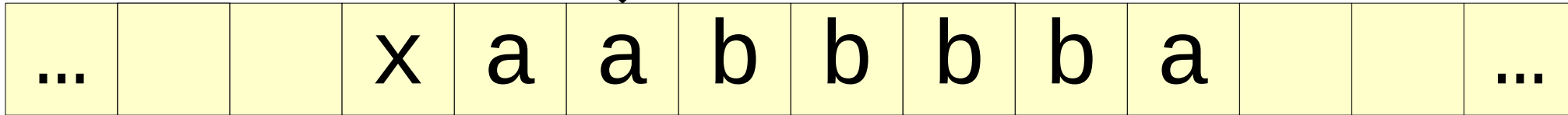
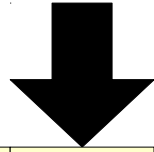

One Solution

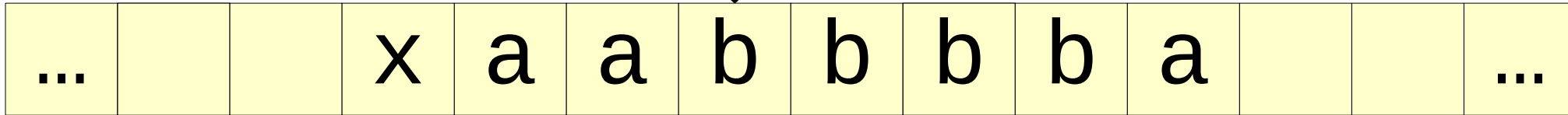
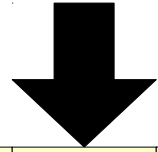

One Solution

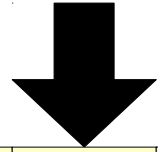

...			x	a	a	x	b	b	b	a			...
-----	--	--	---	---	---	---	---	---	---	---	--	--	-----

One Solution

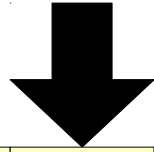

...			x	a	a	x	b	b	b	a			...
-----	--	--	---	---	---	---	---	---	---	---	--	--	-----

One Solution

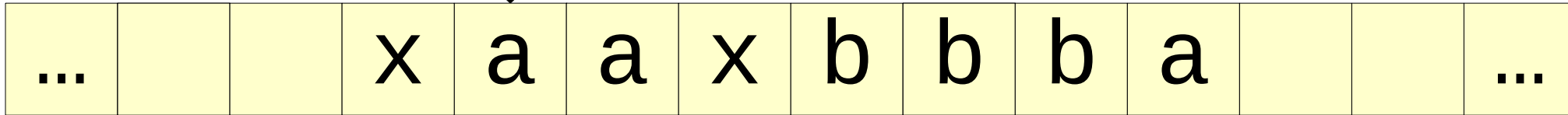
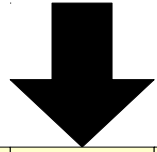

One Solution

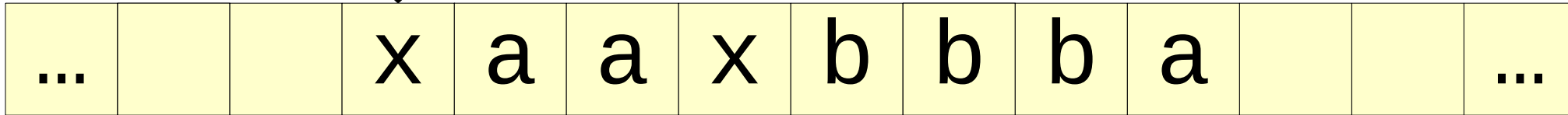
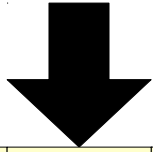

One Solution

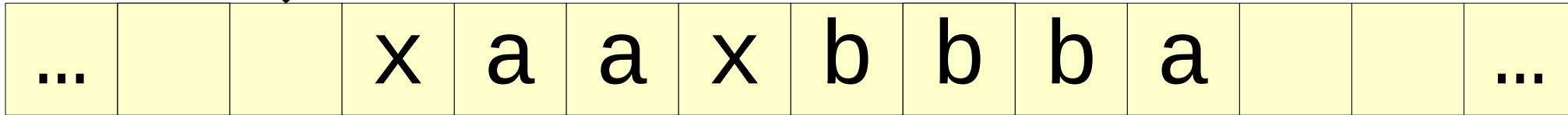
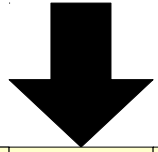

One Solution

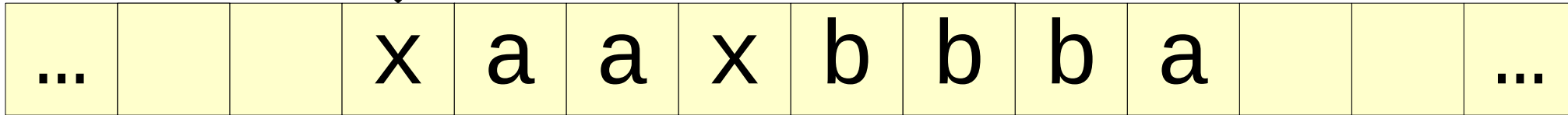
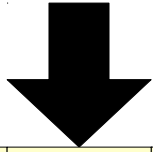

One Solution

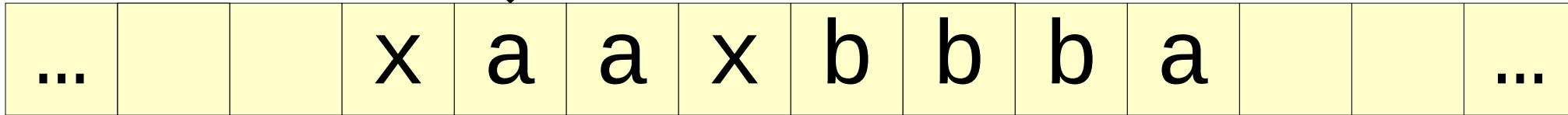
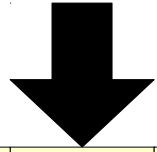

One Solution

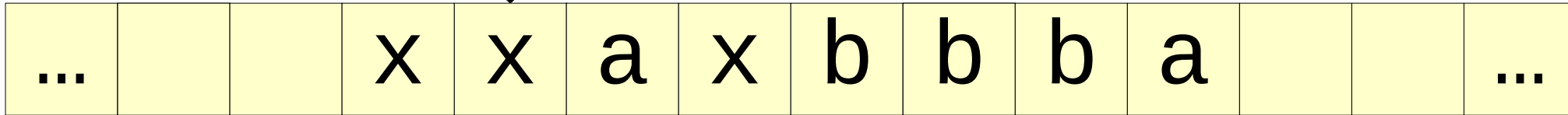
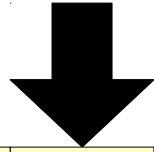

One Solution

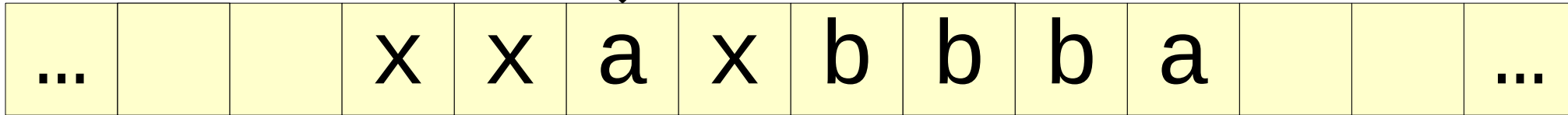
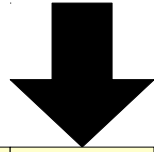

One Solution

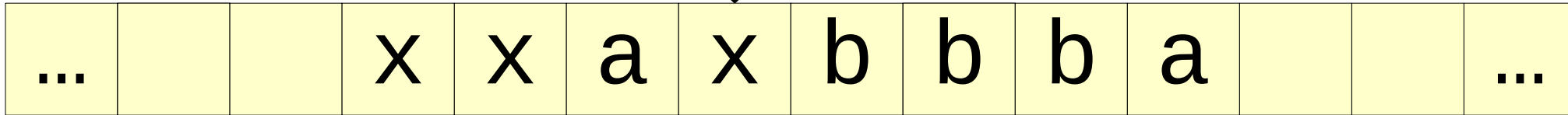
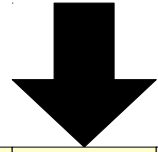

One Solution

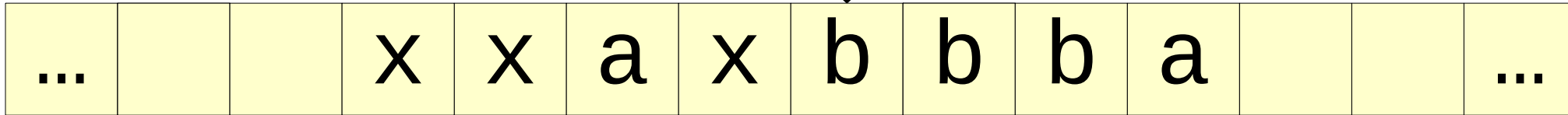
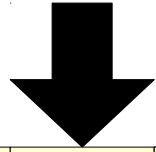

One Solution

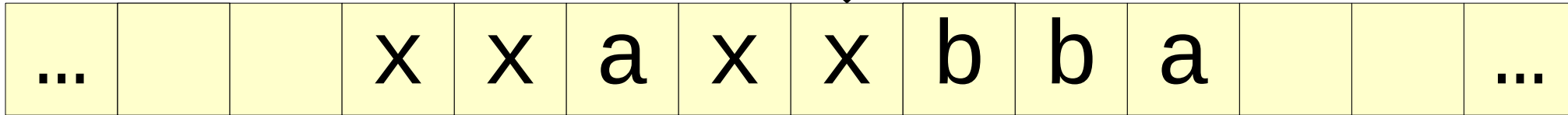
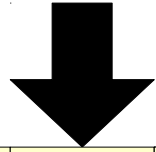

Extra Characters and the Tape Alphabet

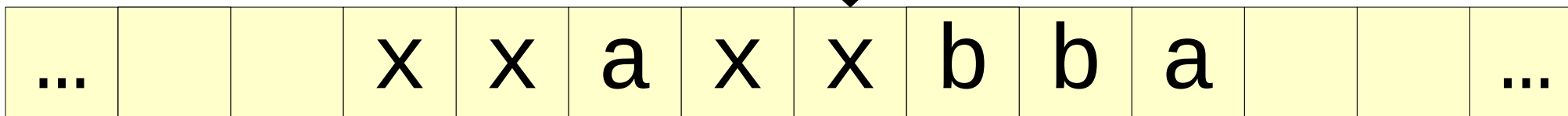
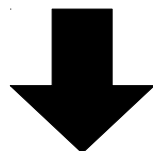

Turing Machine fun fact: there's the **alphabet** Σ that a TM's language is over, but a *separate* **tape alphabet** that is allowed to have more characters. In fact, the tape alphabet will *always* include at least one more character than Σ , the "blank" character. We can add any other characters we want to the tape alphabet.

Start:

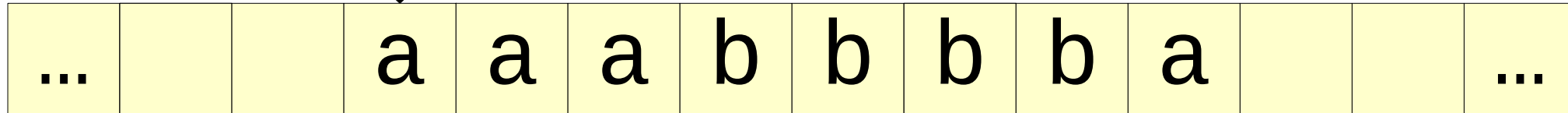
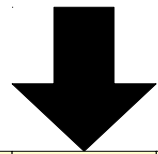

Start:

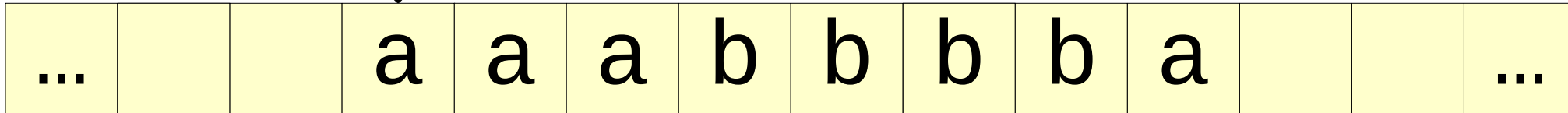
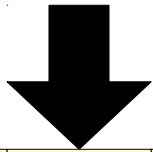

Start:

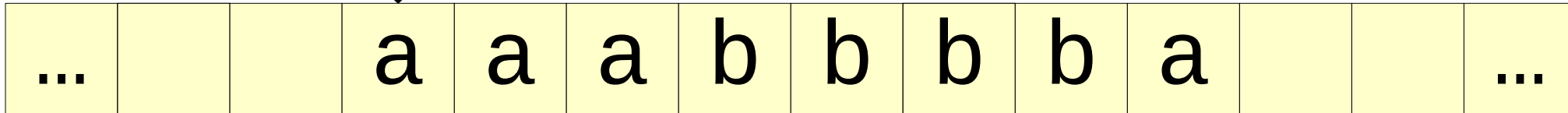
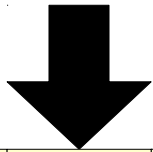

Start:

If 'a' Goto FoundA

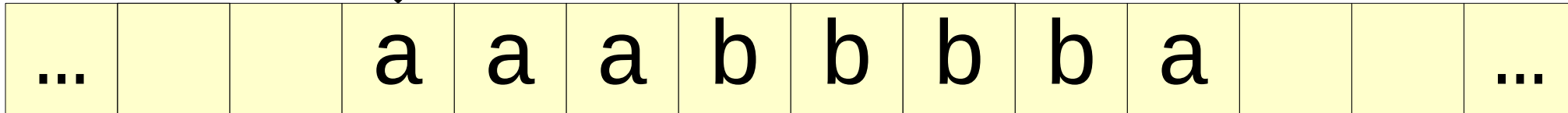
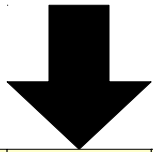

Start:

If 'a' Goto FoundA

FoundA:

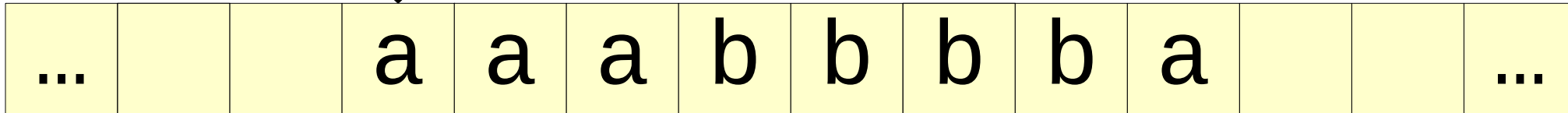
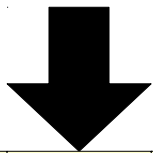

```
Start:  
  If 'a' Goto FoundA
```

FoundA:

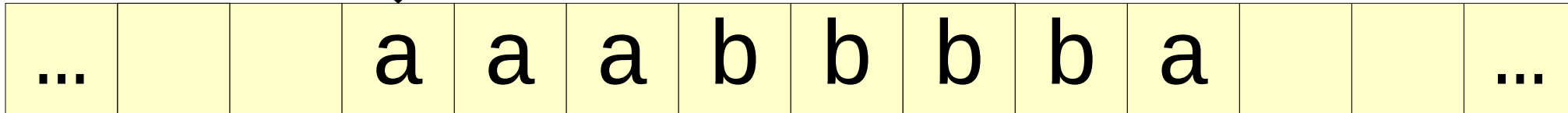
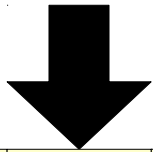

```
Start:  
  If 'a' Goto FoundA
```

```
FoundA:
```

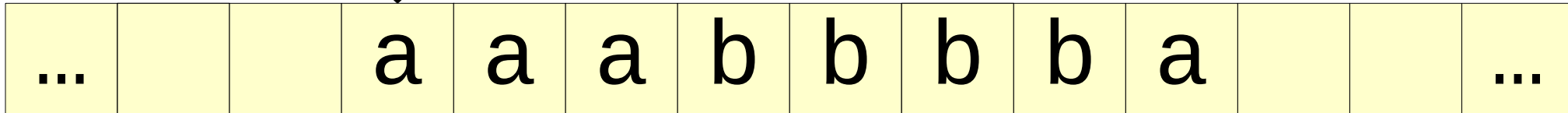
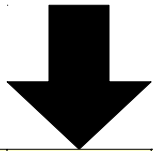

```
Start:  
  If 'a' Goto FoundA
```

```
FoundA:  
Write 'x'
```

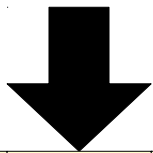

...			a	a	a	b	b	b	b	a			...
-----	--	--	---	---	---	---	---	---	---	---	--	--	-----

```
Start:  
  If 'a' Goto FoundA
```

```
FoundA:  
Write 'x'
```

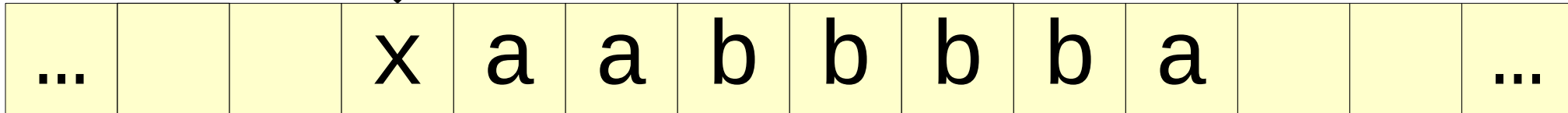
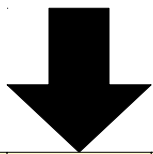

```
Start:  
  If 'a' Goto FoundA
```

```
FoundA:  
  Write 'x'
```

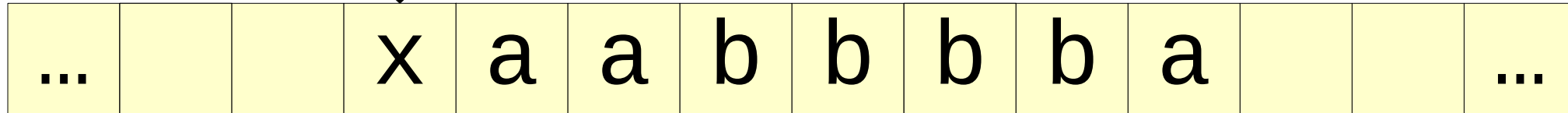
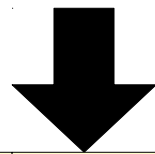

```
Start:  
  If 'a' Goto FoundA
```

```
FoundA:  
  Write 'x'  
  Move Right
```

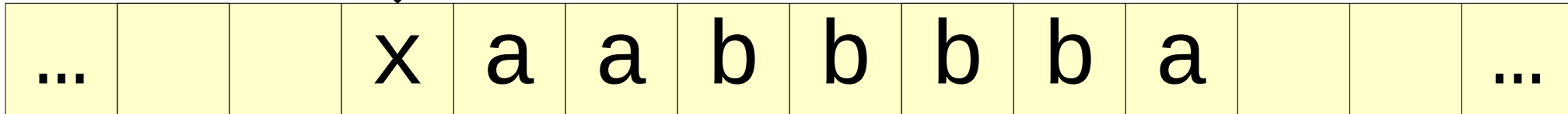
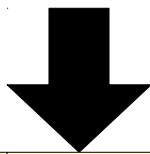

```
Start:  
  If 'a' Goto FoundA
```

```
FoundA:  
  Write 'x'  
  Move Right
```

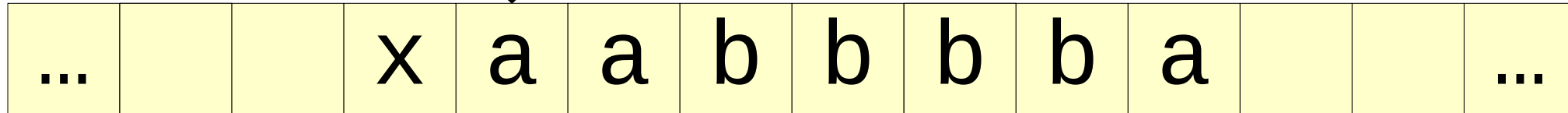
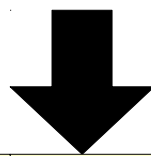

```
Start:  
  If 'a' Goto FoundA
```

```
FoundA:  
  Write 'x'  
  Move Right  
  If 'a' ?
```

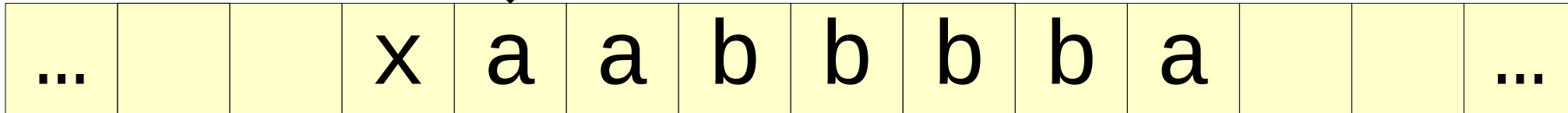
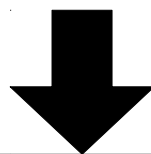

```
Start:  
  If 'a' Goto FoundA
```

```
FoundA:  
  Write 'x'
```

```
  Move Right  
  If 'a' ?
```

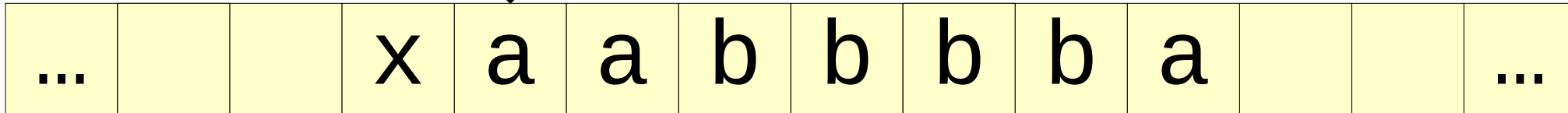
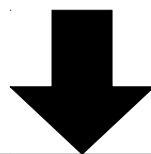

```
Start:  
  If 'a' Goto FoundA
```

```
FoundA:  
  Write 'x'
```

```
LoopA:  
  Move Right  
  If 'a' ?
```

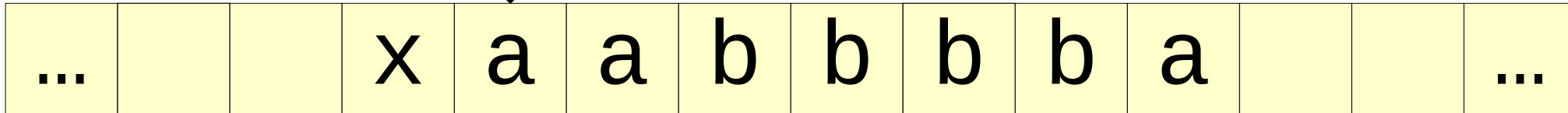
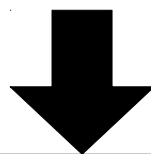

```
Start:  
  If 'a' Goto FoundA
```

```
FoundA:  
  Write 'x'
```

```
LoopA:  
  Move Right  
  If 'a' Goto LoopA
```

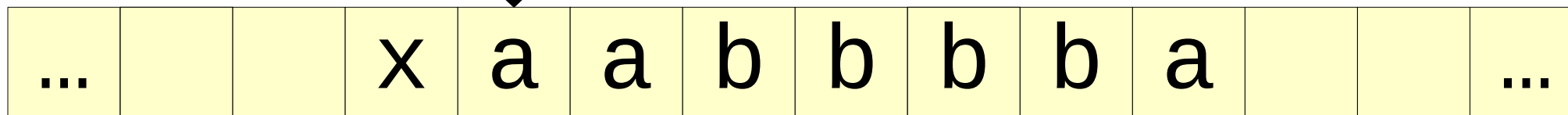
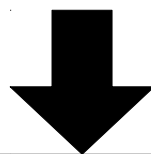

```
Start:  
  If 'a' Goto FoundA
```

```
FoundA:  
  Write 'x'
```

```
LoopA:  
  Move Right  
  If 'a' Goto LoopA
```

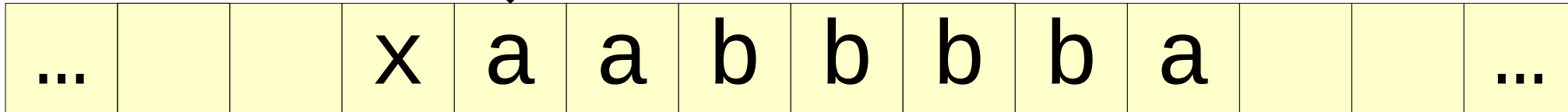
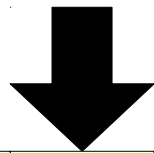

```
Start:  
  If 'a' Goto FoundA
```

```
FoundA:  
  Write 'x'
```

```
LoopA:  
  Move Right  
  If 'a' Goto LoopA
```

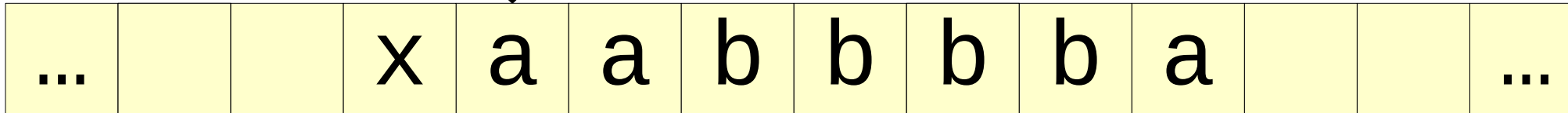
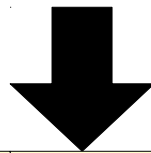

```
Start:  
  If 'a' Goto FoundA
```

```
FoundA:  
  Write 'x'
```

```
LoopA:  
  Move Right  
  If 'a' Goto LoopA
```

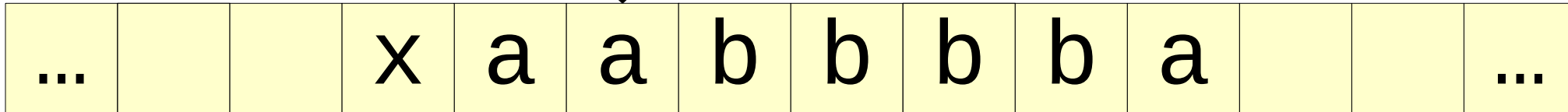
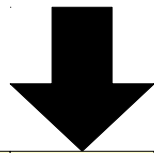

```
Start:  
  If 'a' Goto FoundA
```

```
FoundA:  
  Write 'x'
```

```
LoopA:  
  Move Right
```

```
  If 'a' Goto LoopA
```

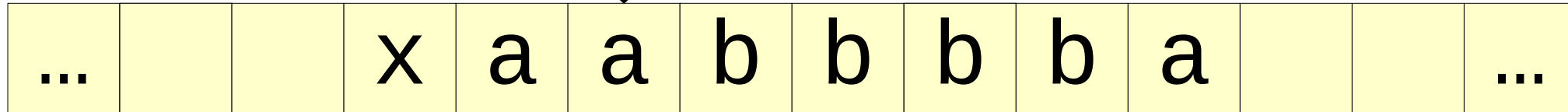
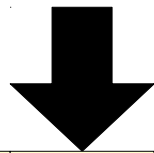

```
Start:  
  If 'a' Goto FoundA
```

```
FoundA:  
  Write 'x'
```

```
LoopA:  
  Move Right  
  If 'a' Goto LoopA
```

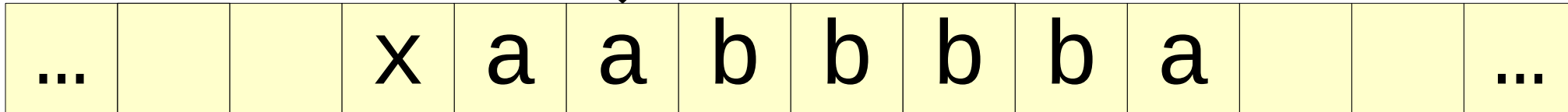
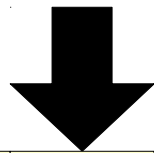

```
Start:  
  If 'a' Goto FoundA
```

```
FoundA:  
  Write 'x'
```

```
LoopA:  
  Move Right  
  If 'a' Goto LoopA
```

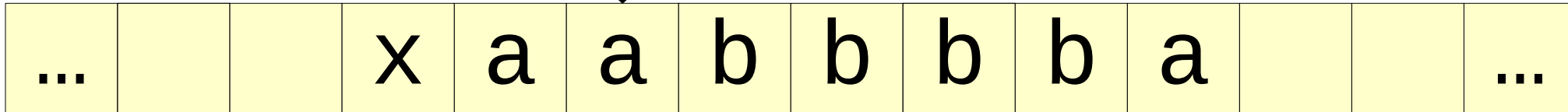
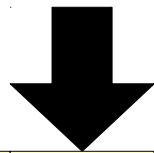

```
Start:  
  If 'a' Goto FoundA
```

```
FoundA:  
  Write 'x'
```

```
LoopA:  
  Move Right  
  If 'a' Goto LoopA
```

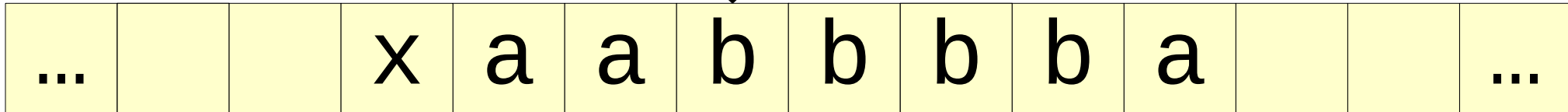
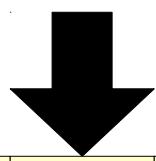

```
Start:  
  If 'a' Goto FoundA
```

```
FoundA:  
  Write 'x'
```

```
LoopA:  
  Move Right  
  If 'a' Goto LoopA
```

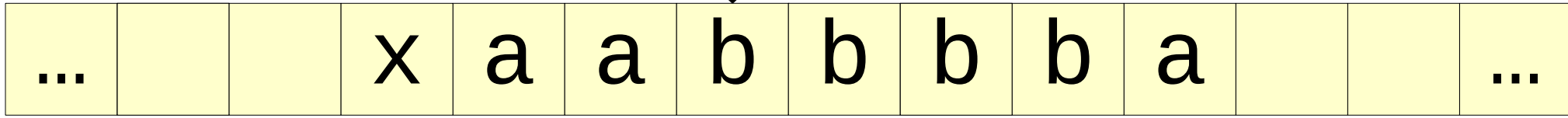
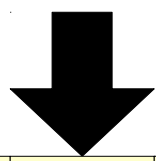

```
Start:  
  If 'a' Goto FoundA
```

```
FoundA:  
  Write 'x'
```

```
LoopA:  
  Move Right  
  If 'a' Goto LoopA
```

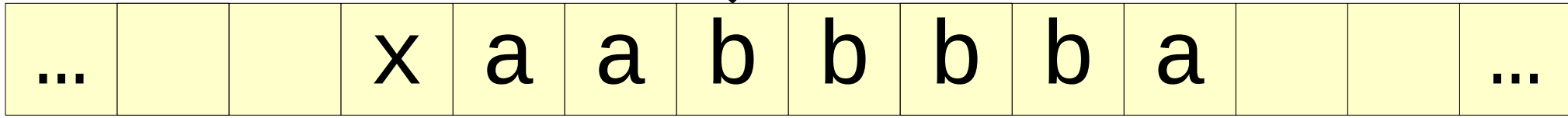
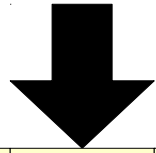

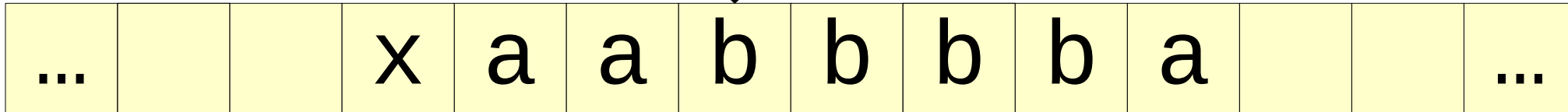
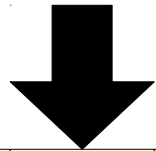

```
Start:  
  If 'a' Goto FoundA  
  
FoundA:  
  Write 'x'  
  
LoopA:  
  Move Right  
  If 'a' Goto LoopA  
  Write 'x'
```

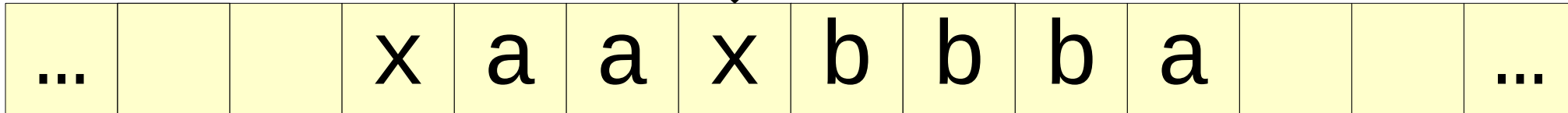
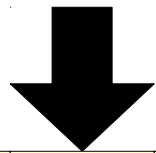

```
Start:  
  If 'a' Goto FoundA  
  
FoundA:  
  Write 'x'  
LoopA:  
  Move Right  
  If 'a' Goto LoopA  
Write 'x'
```

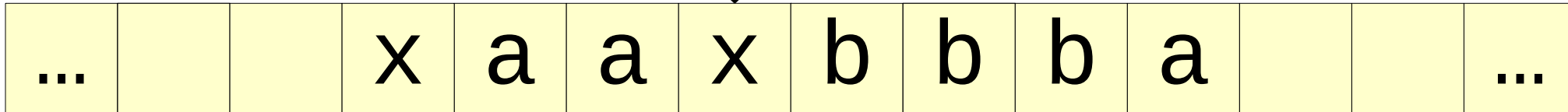
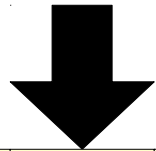

```
Start:  
  If 'a' Goto FoundA  
  
FoundA:  
  Write 'x'  
LoopA:  
  Move Right  
  If 'a' Goto LoopA  
  Write 'x'
```



```
Start:  
  If 'a' Goto FoundA
```

```
FoundA:  
  Write 'x'
```

```
LoopA:  
  Move Right  
  If 'a' Goto LoopA  
  Write 'x'  
  Goto GoHome
```

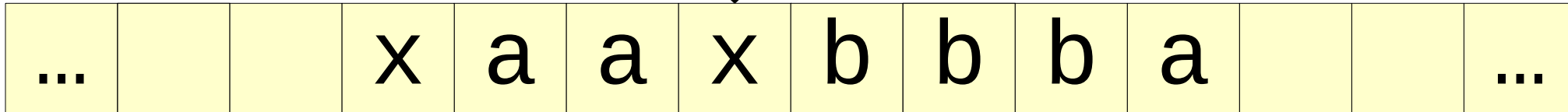
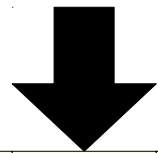

```
Start:  
  If 'a' Goto FoundA
```

```
FoundA:  
  Write 'x'
```

```
LoopA:  
  Move Right  
  If 'a' Goto LoopA  
  Write 'x'  
  Goto GoHome
```

```
GoHome:  
  Move Left  
  If Not Blank Goto GoHome  
  Move Right  
  Goto Start
```

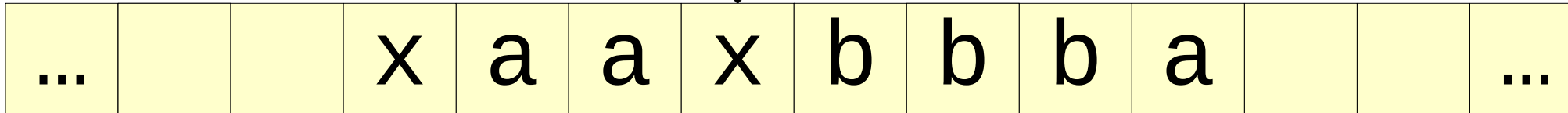
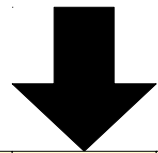

```
Start:  
  If 'a' Goto FoundA  
  
FoundA:  
  Write 'x'  
  
LoopA:  
  Move Right  
  If 'a' Goto LoopA  
  Write 'x'  
  Goto GoHome
```

```
GoHome:  
  Move Left  
  If Not Blank Goto GoHome  
  Move Right  
  Goto Start
```

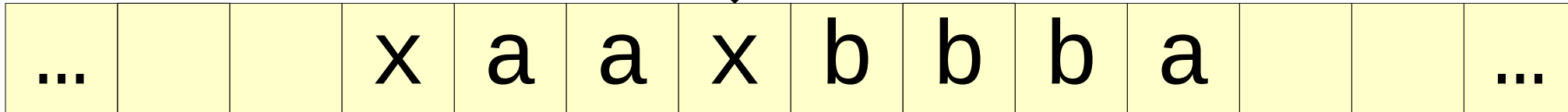
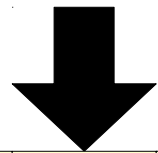

```
Start:  
  If 'a' Goto FoundA
```

```
FoundA:  
  Write 'x'
```

```
LoopA:  
  Move Right  
  If 'a' Goto LoopA  
  Write 'x'  
  Goto GoHome
```

```
GoHome:  
  Move Left  
  If Not Blank Goto GoHome  
  Move Right  
  Goto Start
```

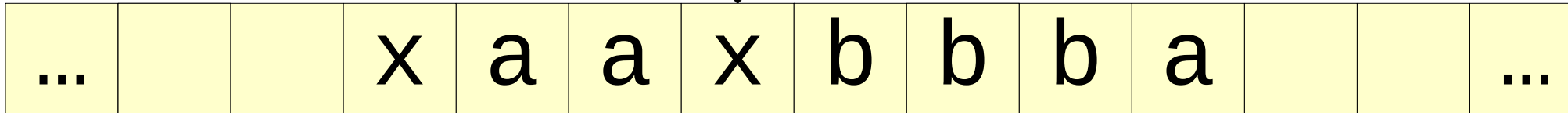
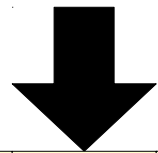

```
Start:  
  If 'a' Goto FoundA
```

```
FoundA:  
  Write 'x'
```

```
LoopA:  
  Move Right  
  If 'a' Goto LoopA  
  Write 'x'  
  Goto GoHome
```

```
GoHome:  
  Move Left  
  If Not Blank Goto GoHome  
  Move Right  
  Goto Start
```

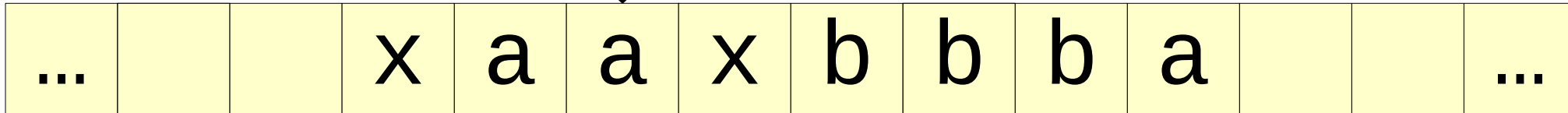
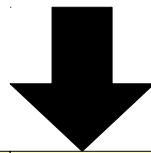

```
Start:  
  If 'a' Goto FoundA
```

```
FoundA:  
  Write 'x'
```

```
LoopA:  
  Move Right  
  If 'a' Goto LoopA  
  Write 'x'  
  Goto GoHome
```

```
GoHome:  
  Move Left  
  If Not Blank Goto GoHome  
  Move Right  
  Goto Start
```

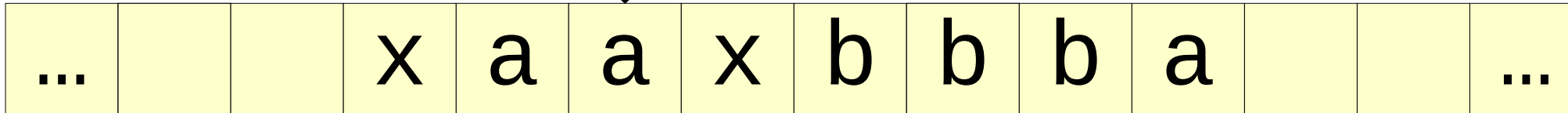
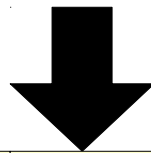

```
Start:
  If 'a' Goto FoundA
FoundA:
  Write 'x'
LoopA:
  Move Right
  If 'a' Goto LoopA
  Write 'x'
  Goto GoHome
```

```
GoHome:
  Move Left
  If Not Blank Goto GoHome
  Move Right
  Goto Start
```

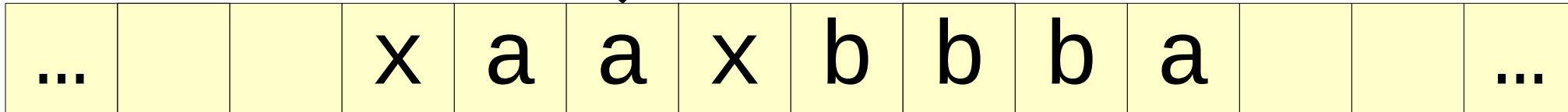
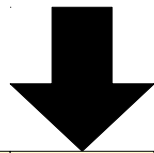

```
Start:  
  If 'a' Goto FoundA
```

```
FoundA:  
  Write 'x'
```

```
LoopA:  
  Move Right  
  If 'a' Goto LoopA  
  Write 'x'  
  Goto GoHome
```

```
GoHome:  
  Move Left  
  If Not Blank Goto GoHome  
  Move Right  
  Goto Start
```

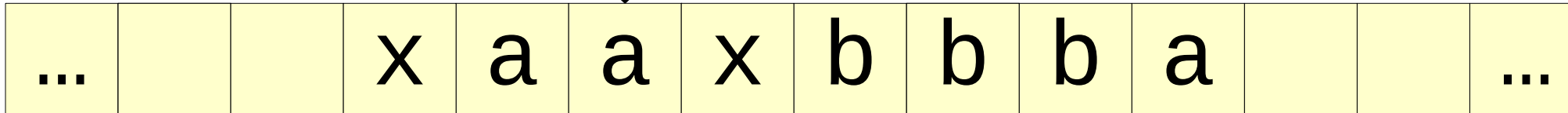
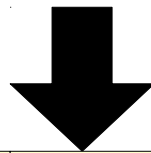

```
Start:  
  If 'a' Goto FoundA
```

```
FoundA:  
  Write 'x'
```

```
LoopA:  
  Move Right  
  If 'a' Goto LoopA  
  Write 'x'  
  Goto GoHome
```

```
GoHome:  
  Move Left  
  If Not Blank Goto GoHome  
  Move Right  
  Goto Start
```

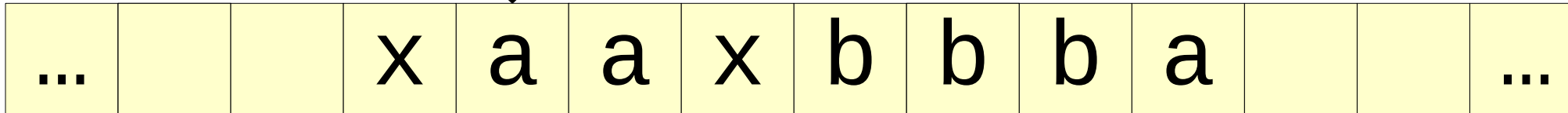
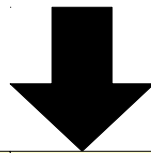

```
Start:  
  If 'a' Goto FoundA
```

```
FoundA:  
  Write 'x'
```

```
LoopA:  
  Move Right  
  If 'a' Goto LoopA  
  Write 'x'  
  Goto GoHome
```

```
GoHome:  
  Move Left  
  If Not Blank Goto GoHome  
  Move Right  
  Goto Start
```

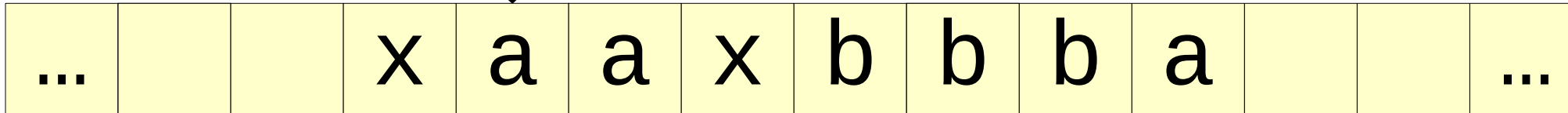
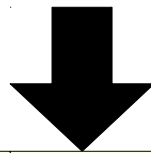

```
Start:  
  If 'a' Goto FoundA  
  
FoundA:  
  Write 'x'  
  
LoopA:  
  Move Right  
  If 'a' Goto LoopA  
  Write 'x'  
  Goto GoHome
```

```
GoHome:  
  Move Left  
  If Not Blank Goto GoHome  
  Move Right  
  Goto Start
```

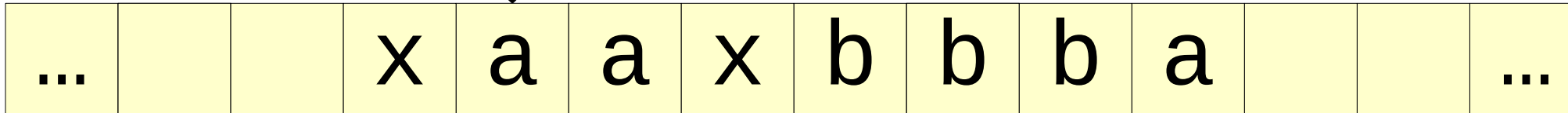
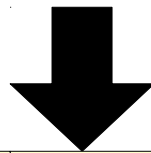

```
Start:  
  If 'a' Goto FoundA
```

```
FoundA:  
  Write 'x'
```

```
LoopA:  
  Move Right  
  If 'a' Goto LoopA  
  Write 'x'  
  Goto GoHome
```

```
GoHome:  
  Move Left  
  If Not Blank Goto GoHome  
  Move Right  
  Goto Start
```

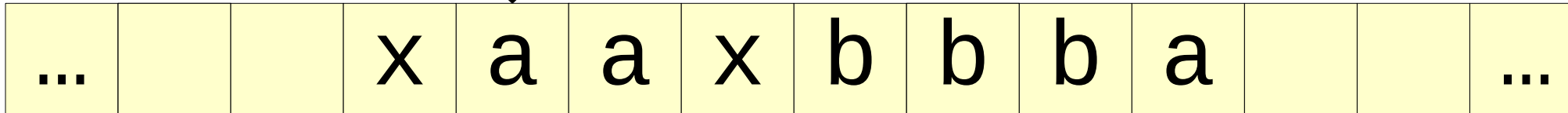
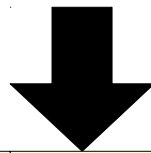

```
Start:  
  If 'a' Goto FoundA
```

```
FoundA:  
  Write 'x'
```

```
LoopA:  
  Move Right  
  If 'a' Goto LoopA  
  Write 'x'  
  Goto GoHome
```

```
GoHome:  
  Move Left  
  If Not Blank Goto GoHome  
  Move Right  
  Goto Start
```

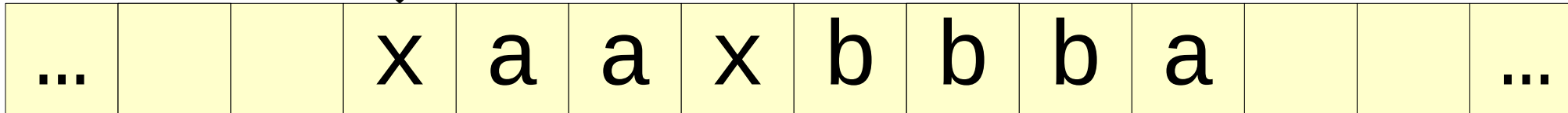
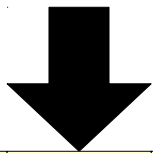

```
Start:  
  If 'a' Goto FoundA
```

```
FoundA:  
  Write 'x'
```

```
LoopA:  
  Move Right  
  If 'a' Goto LoopA  
  Write 'x'  
  Goto GoHome
```

```
GoHome:  
  Move Left  
  If Not Blank Goto GoHome  
  Move Right  
  Goto Start
```

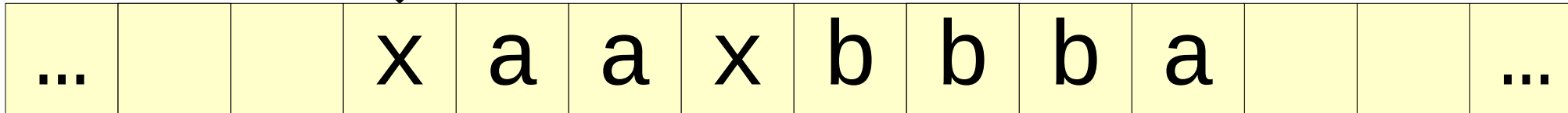
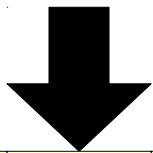

```
Start:  
  If 'a' Goto FoundA  
  
FoundA:  
  Write 'x'  
  
LoopA:  
  Move Right  
  If 'a' Goto LoopA  
  Write 'x'  
  Goto GoHome
```

```
GoHome:  
  Move Left  
  If Not Blank Goto GoHome  
  Move Right  
  Goto Start
```

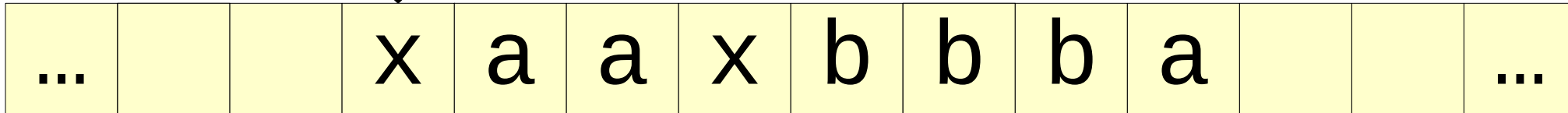
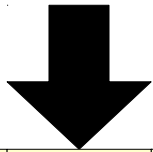

```
Start:  
  If 'a' Goto FoundA
```

```
FoundA:  
  Write 'x'
```

```
LoopA:  
  Move Right  
  If 'a' Goto LoopA  
  Write 'x'  
  Goto GoHome
```

```
GoHome:  
  Move Left  
  If Not Blank Goto GoHome  
  Move Right  
  Goto Start
```

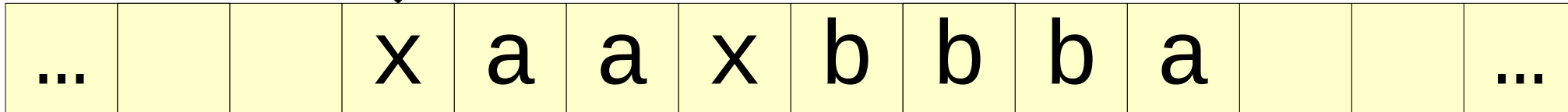
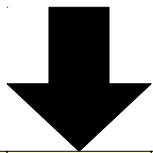

```
Start:  
  If 'a' Goto FoundA
```

```
FoundA:  
  Write 'x'
```

```
LoopA:  
  Move Right  
  If 'a' Goto LoopA  
  Write 'x'  
  Goto GoHome
```

```
GoHome:  
  Move Left  
  If Not Blank Goto GoHome  
  Move Right  
  Goto Start
```

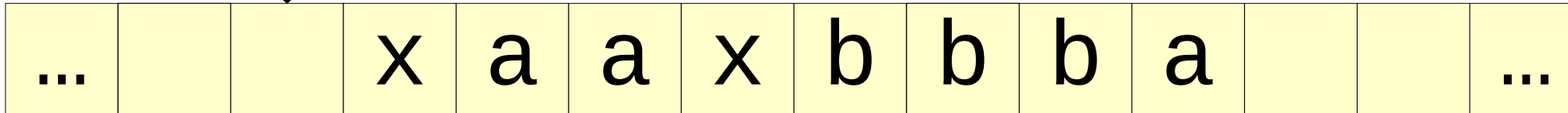
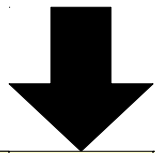

```
Start:  
  If 'a' Goto FoundA
```

```
FoundA:  
  Write 'x'
```

```
LoopA:  
  Move Right  
  If 'a' Goto LoopA  
  Write 'x'  
  Goto GoHome
```

```
GoHome:  
  Move Left  
  If Not Blank Goto GoHome  
  Move Right  
  Goto Start
```

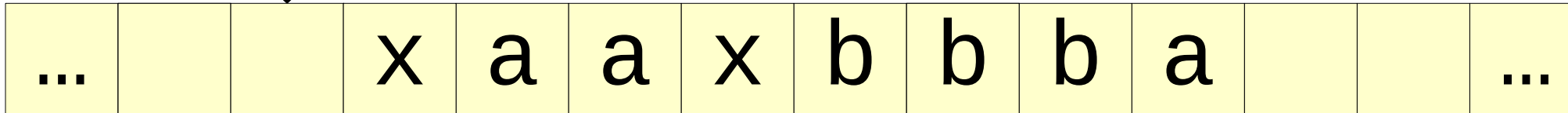
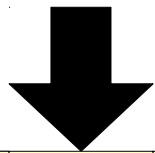

```
Start:  
  If 'a' Goto FoundA
```

```
FoundA:  
  Write 'x'
```

```
LoopA:  
  Move Right  
  If 'a' Goto LoopA  
  Write 'x'  
  Goto GoHome
```

```
GoHome:  
  Move Left  
  If Not Blank Goto GoHome  
  Move Right  
  Goto Start
```

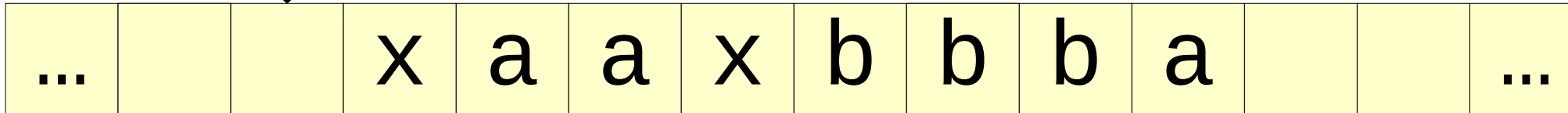
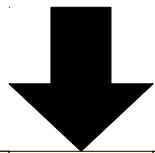

```
Start:  
  If 'a' Goto FoundA
```

```
FoundA:  
  Write 'x'
```

```
LoopA:  
  Move Right  
  If 'a' Goto LoopA  
  Write 'x'  
  Goto GoHome
```

```
GoHome:  
  Move Left  
  If Not Blank Goto GoHome  
  Move Right  
  Goto Start
```

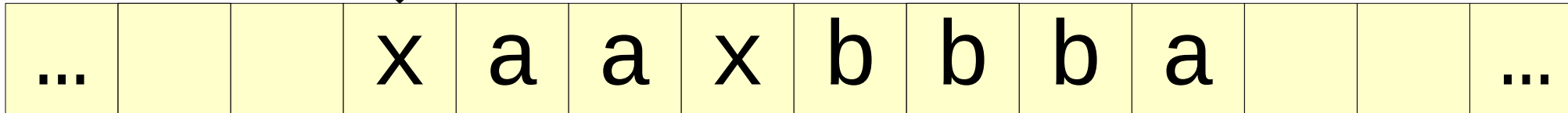
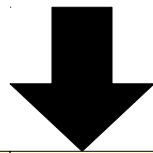

```
Start:  
  If 'a' Goto FoundA
```

```
FoundA:  
  Write 'x'
```

```
LoopA:  
  Move Right  
  If 'a' Goto LoopA  
  Write 'x'  
  Goto GoHome
```

```
GoHome:  
  Move Left  
  If Not Blank Goto GoHome  
  Move Right  
  Goto Start
```

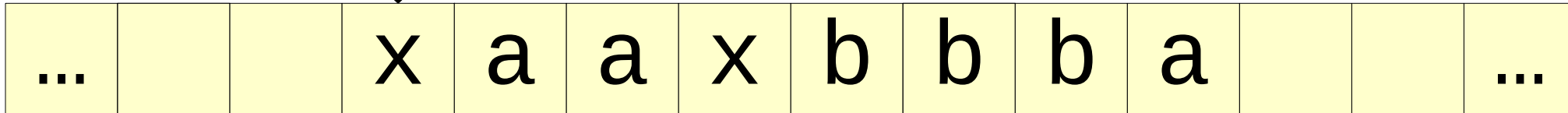
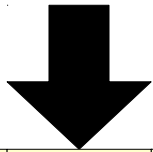

Start:

If 'a' Goto FoundA

FoundA:

Write 'x'

LoopA:

Move Right

If 'a' Goto LoopA

Write 'x'

Goto GoHome

GoHome:

Move Left

If Not Blank Goto GoHome

Move Right

Goto Start

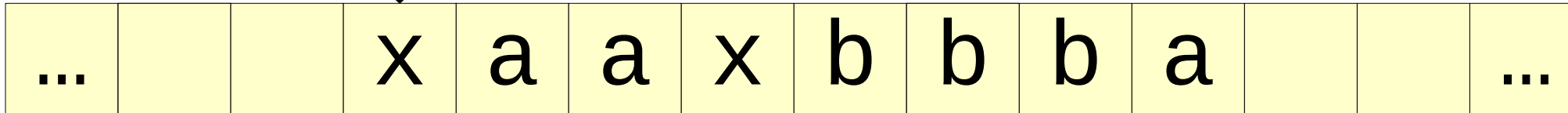
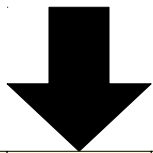

Start:

If 'a' Goto FoundA

FoundA:

Write 'x'

LoopA:

Move Right

If 'a' Goto LoopA

Write 'x'

Goto GoHome

GoHome:

Move Left

If Not Blank Goto GoHome

Move Right

Goto Start

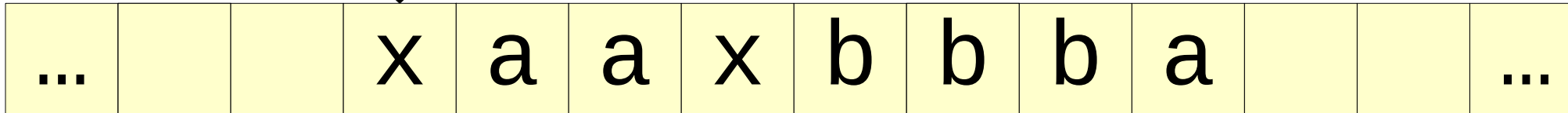
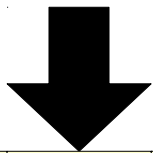

```
Start:  
  If 'a' Goto FoundA
```

```
GoHome:  
  Move Left  
  If Not Blank Goto GoHome  
  Move Right  
  Goto Start
```

```
FoundA:  
  Write 'x'  
LoopA:  
  Move Right  
  If 'a' Goto LoopA  
  Write 'x'  
  Goto GoHome
```

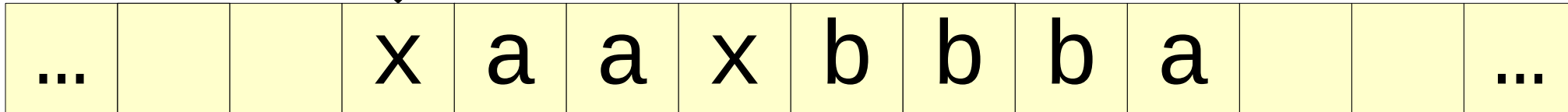
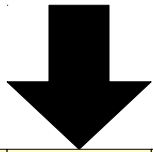

```
Start:  
  If 'a' Goto FoundA  
  Move Right
```

```
FoundA:  
  Write 'x'
```

```
LoopA:  
  Move Right  
  If 'a' Goto LoopA  
  Write 'x'  
  Goto GoHome
```

```
GoHome:  
  Move Left  
  If Not Blank Goto GoHome  
  Move Right  
  Goto Start
```

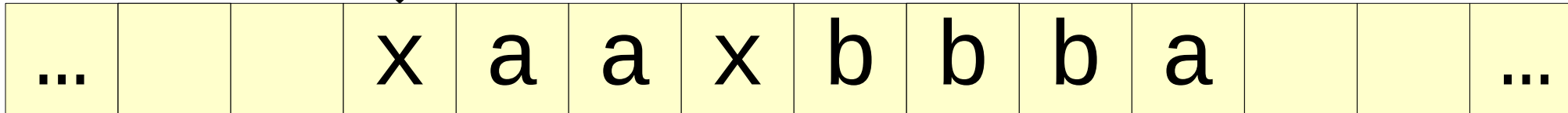
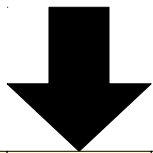

```
Start:  
  If 'a' Goto FoundA  
  Move Right
```

```
FoundA:  
  Write 'x'
```

```
LoopA:  
  Move Right  
  If 'a' Goto LoopA  
  Write 'x'  
  Goto GoHome
```

```
GoHome:  
  Move Left  
  If Not Blank Goto GoHome  
  Move Right  
  Goto Start
```

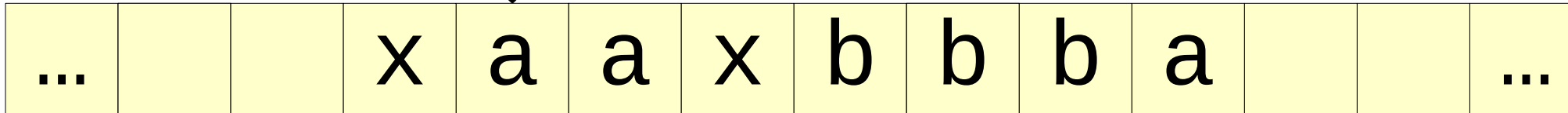
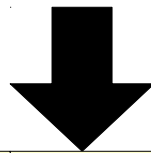

```
Start:  
  If 'a' Goto FoundA  
  Move Right
```

```
GoHome:  
  Move Left  
  If Not Blank Goto GoHome  
  Move Right  
  Goto Start
```

```
FoundA:  
  Write 'x'  
LoopA:  
  Move Right  
  If 'a' Goto LoopA  
  Write 'x'  
  Goto GoHome
```

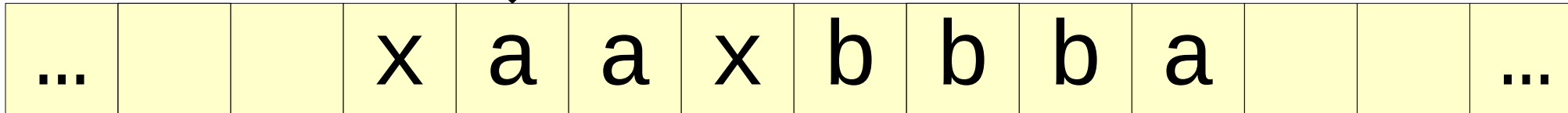
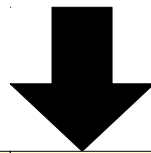

```
Start:  
  If 'a' Goto FoundA  
  Move Right  
  Goto Start
```

```
GoHome:  
  Move Left  
  If Not Blank Goto GoHome  
  Move Right  
  Goto Start
```

```
FoundA:  
  Write 'x'  
LoopA:  
  Move Right  
  If 'a' Goto LoopA  
  Write 'x'  
  Goto GoHome
```

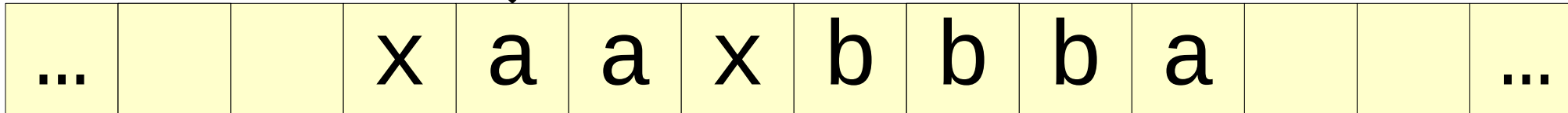
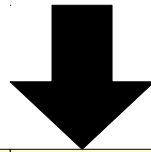

Start:

```
If 'a' Goto FoundA  
Move Right  
Goto Start
```

FoundA:

```
Write 'x'
```

LoopA:

```
Move Right  
If 'a' Goto LoopA  
Write 'x'  
Goto GoHome
```

GoHome:

```
Move Left  
If Not Blank Goto GoHome  
Move Right  
Goto Start
```

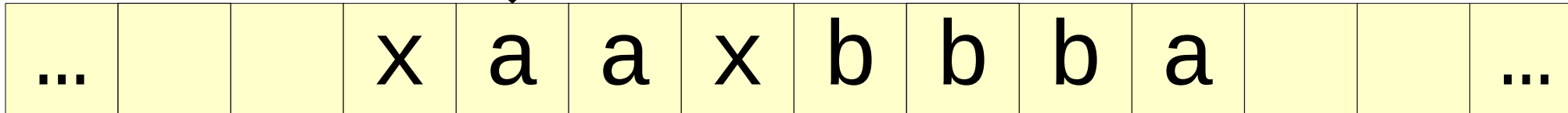
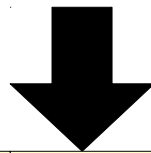

Start:

If 'a' Goto FoundA

Move Right

Goto Start

FoundA:

Write 'x'

LoopA:

Move Right

If 'a' Goto LoopA

Write 'x'

Goto GoHome

GoHome:

Move Left

If Not Blank Goto GoHome

Move Right

Goto Start

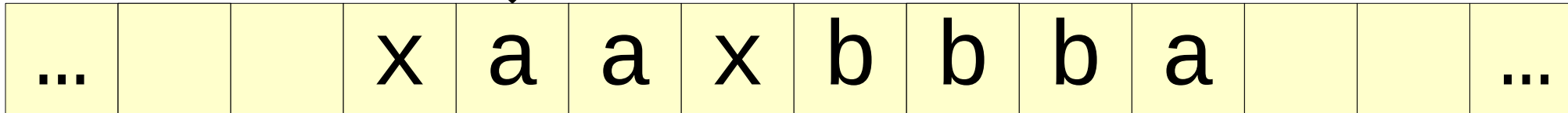
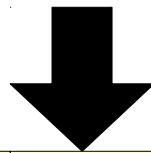

```
Start:  
  If 'a' Goto FoundA  
  Move Right  
  Goto Start
```

```
GoHome:  
  Move Left  
  If Not Blank Goto GoHome  
  Move Right  
  Goto Start
```

FoundA:

```
  Write 'x'  
LoopA:  
  Move Right  
  If 'a' Goto LoopA  
  Write 'x'  
  Goto GoHome
```

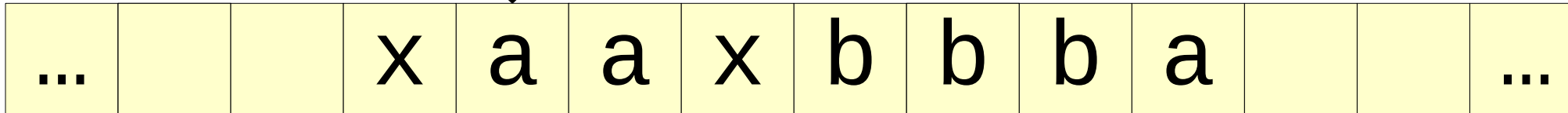
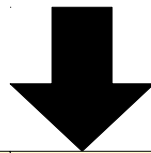

```
Start:  
  If 'a' Goto FoundA  
  Move Right  
  Goto Start
```

```
GoHome:  
  Move Left  
  If Not Blank Goto GoHome  
  Move Right  
  Goto Start
```

```
FoundA:
```

```
Write 'x'
```

```
LoopA:
```

```
Move Right
```

```
If 'a' Goto LoopA
```

```
Write 'x'
```

```
Goto GoHome
```

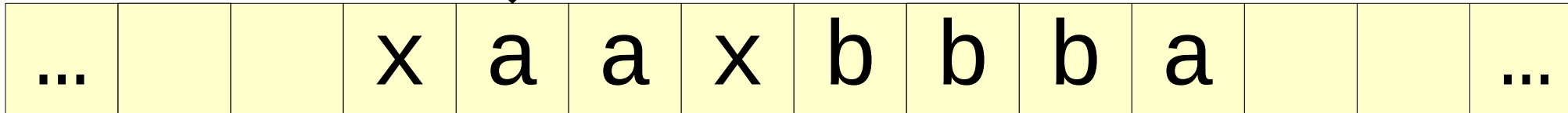
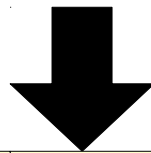

```
Start:  
  If 'a' Goto FoundA  
  Move Right  
  Goto Start
```

```
GoHome:  
  Move Left  
  If Not Blank Goto GoHome  
  Move Right  
  Goto Start
```

```
FoundA:
```

```
Write 'x'
```

```
LoopA:
```

```
Move Right
```

```
If 'a' Goto LoopA
```

```
Write 'x'
```

```
Goto GoHome
```

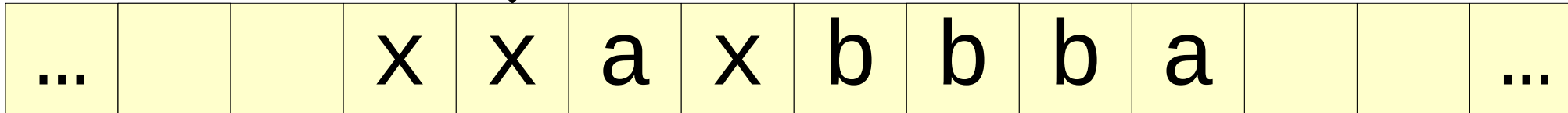
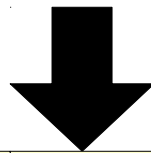

```
Start:  
  If 'a' Goto FoundA  
  Move Right  
  Goto Start
```

```
FoundA:  
  Write 'x'
```

```
LoopA:  
  Move Right  
  If 'a' Goto LoopA  
  Write 'x'  
  Goto GoHome
```

```
GoHome:  
  Move Left  
  If Not Blank Goto GoHome  
  Move Right  
  Goto Start
```

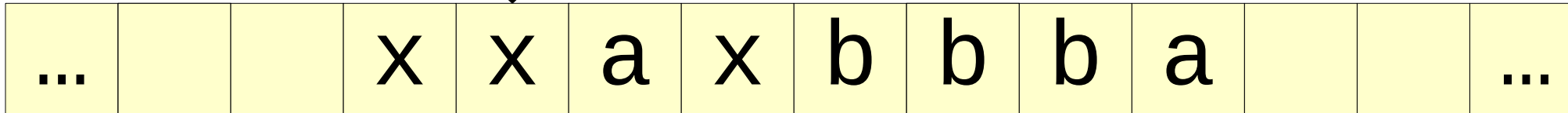
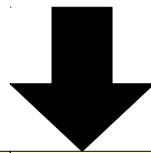

```
Start:  
  If 'a' Goto FoundA  
  Move Right  
  Goto Start
```

```
FoundA:  
  Write 'x'
```

```
LoopA:  
  Move Right  
  If 'a' Goto LoopA  
  Write 'x'  
  Goto GoHome
```

```
GoHome:  
  Move Left  
  If Not Blank Goto GoHome  
  Move Right  
  Goto Start
```

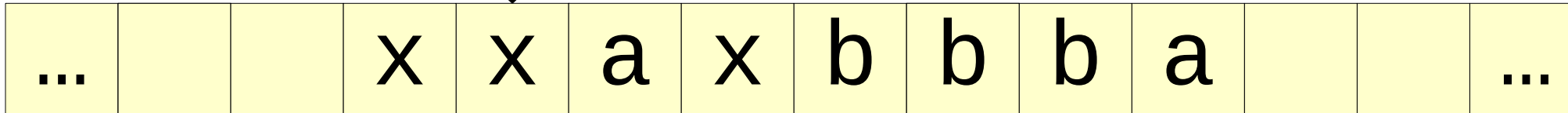
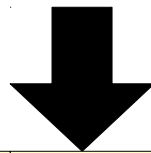

```
Start:  
  If 'a' Goto FoundA  
  Move Right  
  Goto Start
```

```
FoundA:  
  Write 'x'
```

```
LoopA:  
  Move Right  
  If 'a' Goto LoopA  
  Write 'x'  
  Goto GoHome
```

```
GoHome:  
  Move Left  
  If Not Blank Goto GoHome  
  Move Right  
  Goto Start
```

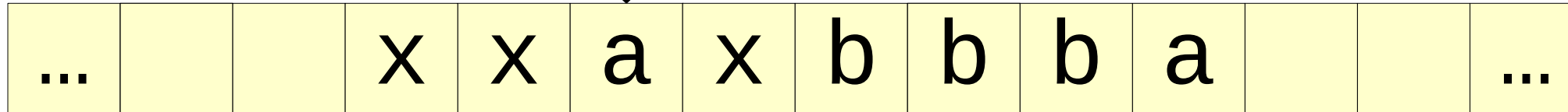
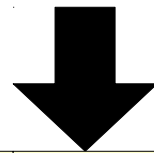

```
Start:  
  If 'a' Goto FoundA  
  Move Right  
  Goto Start
```

```
FoundA:  
  Write 'x'
```

```
LoopA:  
  Move Right  
  If 'a' Goto LoopA  
  Write 'x'  
  Goto GoHome
```

```
GoHome:  
  Move Left  
  If Not Blank Goto GoHome  
  Move Right  
  Goto Start
```

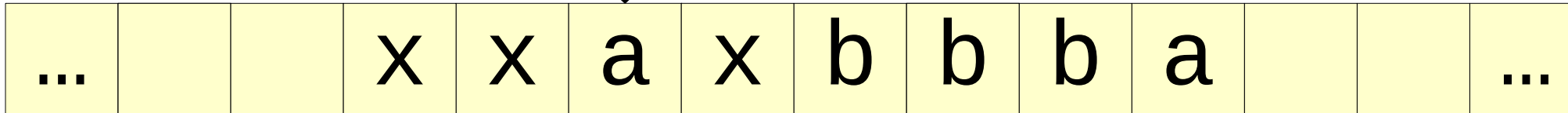
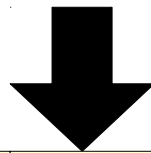

```
Start:  
  If 'a' Goto FoundA  
  Move Right  
  Goto Start
```

```
FoundA:  
  Write 'x'
```

```
LoopA:  
  Move Right  
  If 'a' Goto LoopA  
  Write 'x'  
  Goto GoHome
```

```
GoHome:  
  Move Left  
  If Not Blank Goto GoHome  
  Move Right  
  Goto Start
```

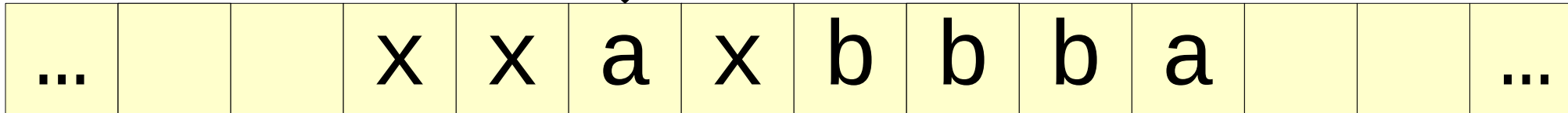
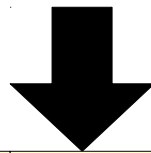

```
Start:  
  If 'a' Goto FoundA  
  Move Right  
  Goto Start
```

```
FoundA:  
  Write 'x'
```

```
LoopA:  
  Move Right  
  If 'a' Goto LoopA  
  Write 'x'  
  Goto GoHome
```

```
GoHome:  
  Move Left  
  If Not Blank Goto GoHome  
  Move Right  
  Goto Start
```

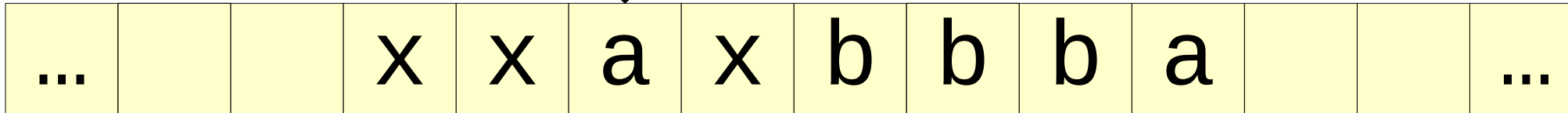
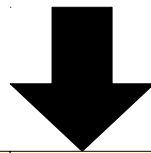

```
Start:  
  If 'a' Goto FoundA  
  Move Right  
  Goto Start
```

```
FoundA:  
  Write 'x'
```

```
LoopA:  
  Move Right  
  If 'a' Goto LoopA  
  Write 'x'  
  Goto GoHome
```

```
GoHome:  
  Move Left  
  If Not Blank Goto GoHome  
  Move Right  
  Goto Start
```

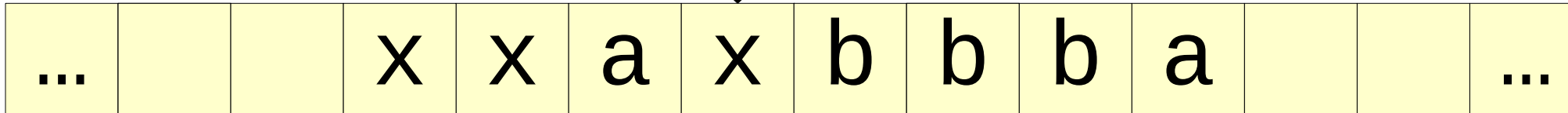
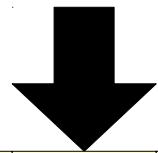

```
Start:  
  If 'a' Goto FoundA  
  Move Right  
  Goto Start
```

```
FoundA:  
  Write 'x'
```

```
LoopA:  
  Move Right  
  If 'a' Goto LoopA  
  Write 'x'  
  Goto GoHome
```

```
GoHome:  
  Move Left  
  If Not Blank Goto GoHome  
  Move Right  
  Goto Start
```

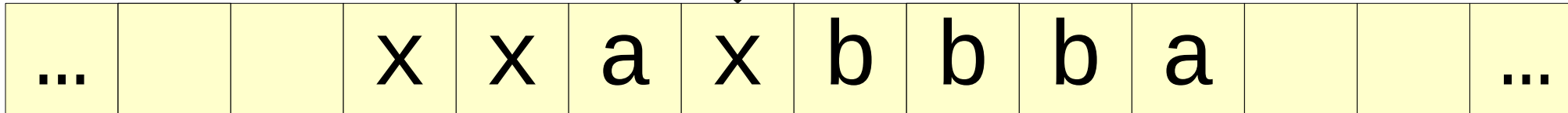
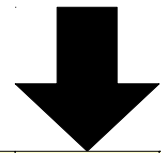

```
Start:  
  If 'a' Goto FoundA  
  Move Right  
  Goto Start
```

```
FoundA:  
  Write 'x'
```

```
LoopA:  
  Move Right  
  If 'a' Goto LoopA
```

```
  Write 'x'  
  Goto GoHome
```

```
GoHome:  
  Move Left  
  If Not Blank Goto GoHome  
  Move Right  
  Goto Start
```

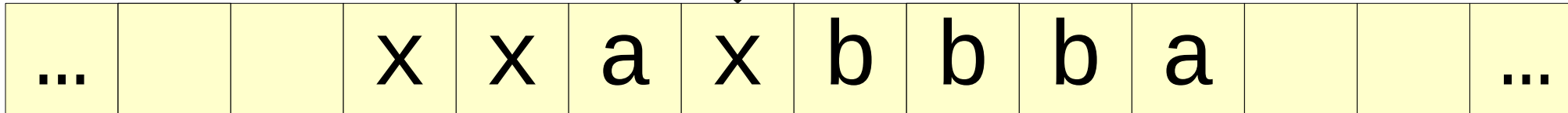
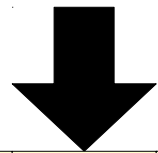

```
Start:  
  If 'a' Goto FoundA  
  Move Right  
  Goto Start
```

```
FoundA:  
  Write 'x'
```

```
LoopA:  
  Move Right  
  If 'a' Goto LoopA
```

```
Write 'x'  
Goto GoHome
```

```
GoHome:  
  Move Left  
  If Not Blank Goto GoHome  
  Move Right  
  Goto Start
```

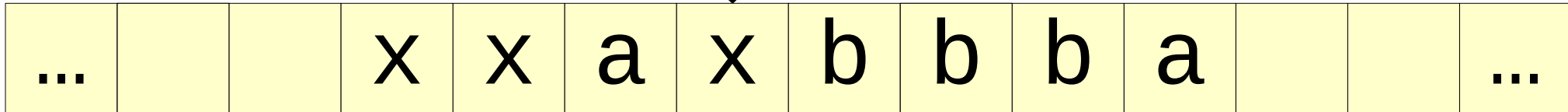
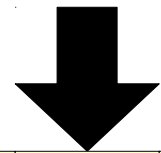

```
Start:  
  If 'a' Goto FoundA  
  Move Right  
  Goto Start
```

```
FoundA:  
  Write 'x'
```

```
LoopA:  
  Move Right  
  If 'a' Goto LoopA  
  If 'x' Goto LoopA  
  Write 'x'  
  Goto GoHome
```

```
GoHome:  
  Move Left  
  If Not Blank Goto GoHome  
  Move Right  
  Goto Start
```

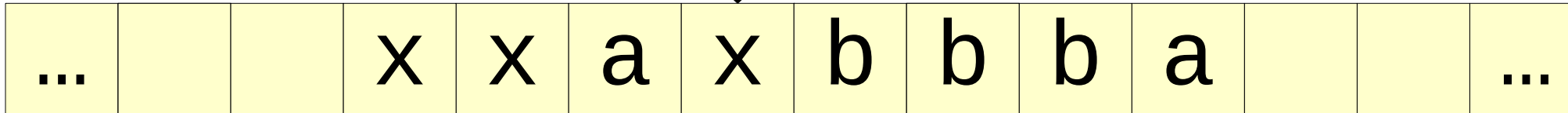
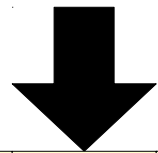

```
Start:  
  If 'a' Goto FoundA  
  Move Right  
  Goto Start
```

```
FoundA:  
  Write 'x'
```

```
LoopA:  
  Move Right  
  If 'a' Goto LoopA  
  If 'x' Goto LoopA  
  Write 'x'  
  Goto GoHome
```

```
GoHome:  
  Move Left  
  If Not Blank Goto GoHome  
  Move Right  
  Goto Start
```

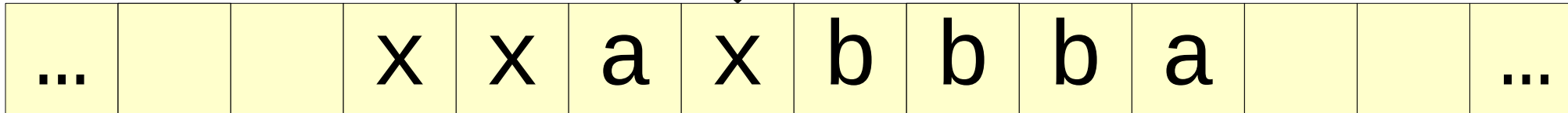
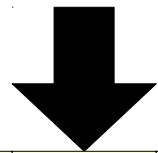

```
Start:  
  If 'a' Goto FoundA  
  Move Right  
  Goto Start
```

```
FoundA:  
  Write 'x'
```

```
LoopA:  
  Move Right  
  If 'a' Goto LoopA  
  If 'x' Goto LoopA  
  Write 'x'  
  Goto GoHome
```

```
GoHome:  
  Move Left  
  If Not Blank Goto GoHome  
  Move Right  
  Goto Start
```

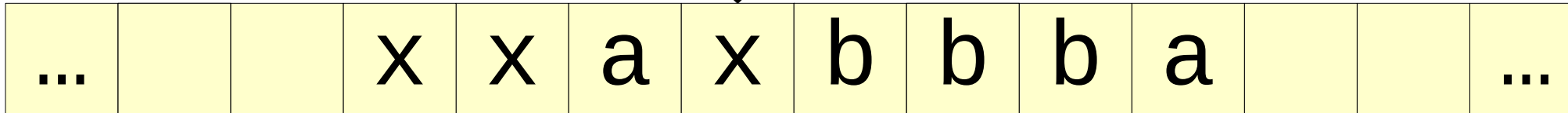
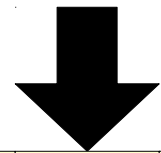

```
Start:  
  If 'a' Goto FoundA  
  Move Right  
  Goto Start
```

```
FoundA:  
  Write 'x'
```

```
LoopA:  
  Move Right  
  If 'a' Goto LoopA  
  If 'x' Goto LoopA  
  Write 'x'  
  Goto GoHome
```

```
GoHome:  
  Move Left  
  If Not Blank Goto GoHome  
  Move Right  
  Goto Start
```

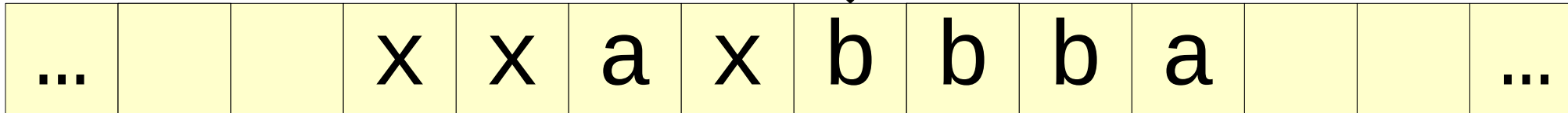
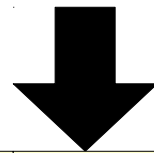

```
Start:  
  If 'a' Goto FoundA  
  Move Right  
  Goto Start
```

```
FoundA:  
  Write 'x'
```

```
LoopA:  
  Move Right  
  If 'a' Goto LoopA  
  If 'x' Goto LoopA  
  Write 'x'  
  Goto GoHome
```

```
GoHome:  
  Move Left  
  If Not Blank Goto GoHome  
  Move Right  
  Goto Start
```

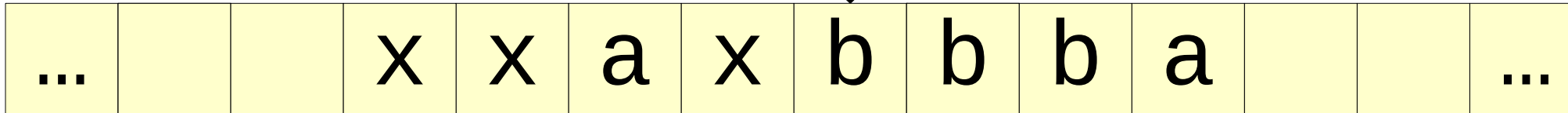
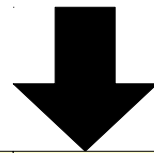

```
Start:  
  If 'a' Goto FoundA  
  Move Right  
  Goto Start
```

```
FoundA:  
  Write 'x'
```

```
LoopA:  
  Move Right  
  If 'a' Goto LoopA  
  If 'x' Goto LoopA  
  Write 'x'  
  Goto GoHome
```

```
GoHome:  
  Move Left  
  If Not Blank Goto GoHome  
  Move Right  
  Goto Start
```

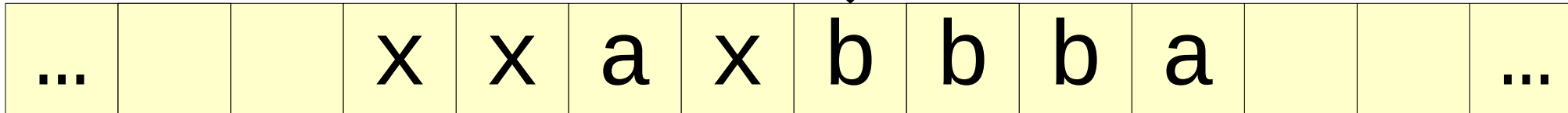
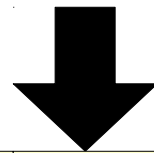

```
Start:  
  If 'a' Goto FoundA  
  Move Right  
  Goto Start
```

```
FoundA:  
  Write 'x'
```

```
LoopA:  
  Move Right  
  If 'a' Goto LoopA  
  If 'x' Goto LoopA  
  Write 'x'  
  Goto GoHome
```

```
GoHome:  
  Move Left  
  If Not Blank Goto GoHome  
  Move Right  
  Goto Start
```

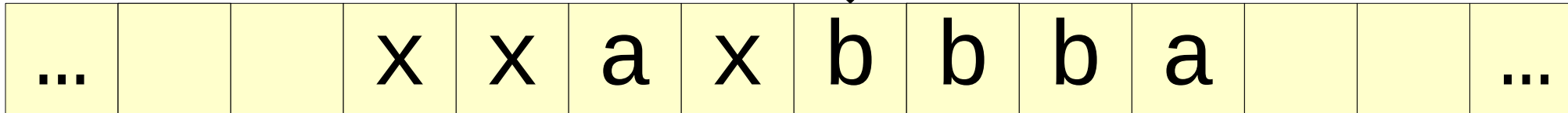
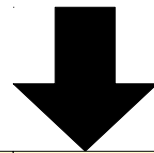

```
Start:  
  If 'a' Goto FoundA  
  Move Right  
  Goto Start
```

```
FoundA:  
  Write 'x'
```

```
LoopA:  
  Move Right  
  If 'a' Goto LoopA  
  If 'x' Goto LoopA  
  Write 'x'  
  Goto GoHome
```

```
GoHome:  
  Move Left  
  If Not Blank Goto GoHome  
  Move Right  
  Goto Start
```

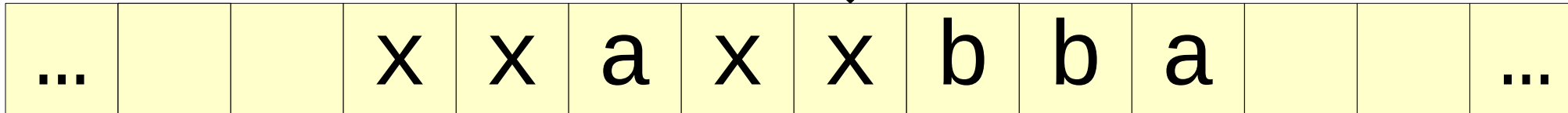
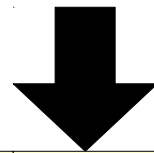

```
Start:  
  If 'a' Goto FoundA  
  Move Right  
  Goto Start
```

```
FoundA:  
  Write 'x'
```

```
LoopA:  
  Move Right  
  If 'a' Goto LoopA  
  If 'x' Goto LoopA  
  Write 'x'  
  Goto GoHome
```

```
GoHome:  
  Move Left  
  If Not Blank Goto GoHome  
  Move Right  
  Goto Start
```

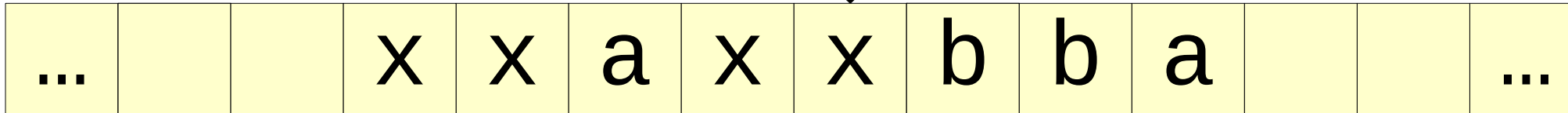
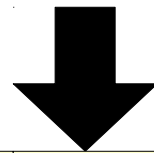

```
Start:  
  If 'a' Goto FoundA  
  Move Right  
  Goto Start
```

```
FoundA:  
  Write 'x'
```

```
LoopA:  
  Move Right  
  If 'a' Goto LoopA  
  If 'x' Goto LoopA  
  Write 'x'  
  Goto GoHome
```

```
GoHome:  
  Move Left  
  If Not Blank Goto GoHome  
  Move Right  
  Goto Start
```

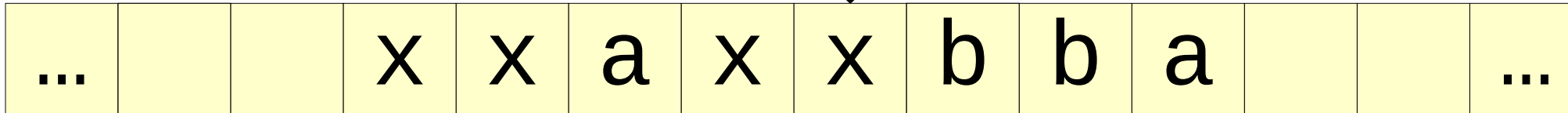
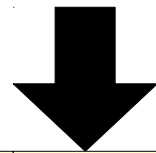

```
Start:  
  If 'a' Goto FoundA  
  Move Right  
  Goto Start
```

```
FoundA:  
  Write 'x'
```

```
LoopA:  
  Move Right  
  If 'a' Goto LoopA  
  If 'x' Goto LoopA  
  Write 'x'  
  Goto GoHome
```

```
GoHome:  
  Move Left  
  If Not Blank Goto GoHome  
  Move Right  
  Goto Start
```

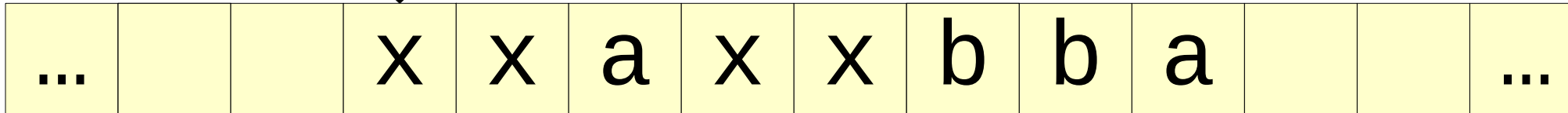
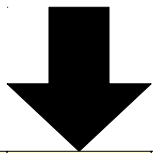

Start:

```
If 'a' Goto FoundA  
Move Right  
Goto Start
```

FoundA:

```
Write 'x'
```

LoopA:

```
Move Right  
If 'a' Goto LoopA  
If 'x' Goto LoopA  
Write 'x'  
Goto GoHome
```

GoHome:

```
Move Left  
If Not Blank Goto GoHome  
Move Right  
Goto Start
```

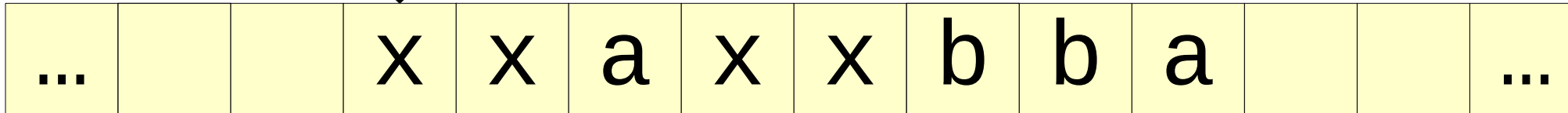
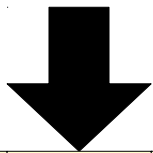

Start:

If 'a' Goto FoundA

Move Right

Goto Start

FoundA:

Write 'x'

LoopA:

Move Right

If 'a' Goto LoopA

If 'x' Goto LoopA

Write 'x'

Goto GoHome

GoHome:

Move Left

If Not Blank Goto GoHome

Move Right

Goto Start

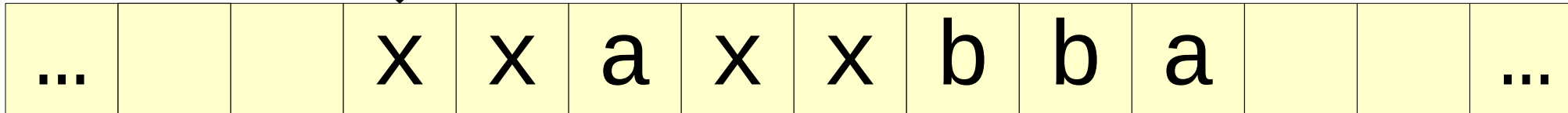
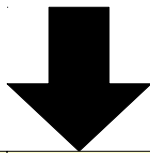

```
Start:  
  If 'a' Goto FoundA  
  Move Right  
  Goto Start
```

```
FoundA:  
  Write 'x'
```

```
LoopA:  
  Move Right  
  If 'a' Goto LoopA  
  If 'x' Goto LoopA  
  Write 'x'  
  Goto GoHome
```

```
GoHome:  
  Move Left  
  If Not Blank Goto GoHome  
  Move Right  
  Goto Start
```

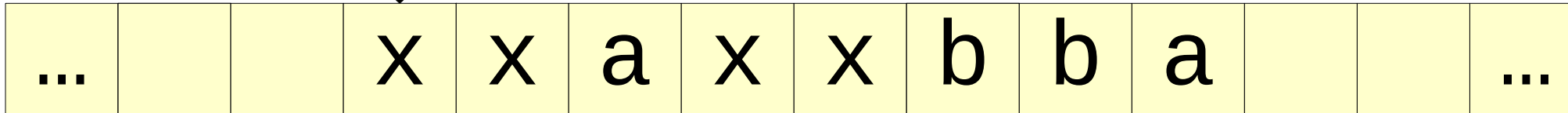
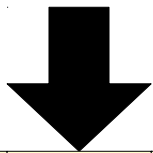

```
Start:  
  If 'a' Goto FoundA  
  Move Right  
  Goto Start
```

```
GoHome:  
  Move Left  
  If Not Blank Goto GoHome  
  Move Right  
  Goto Start
```

```
FoundA:  
  Write 'x'  
LoopA:  
  Move Right  
  If 'a' Goto LoopA  
  If 'x' Goto LoopA  
  Write 'x'  
  Goto GoHome
```

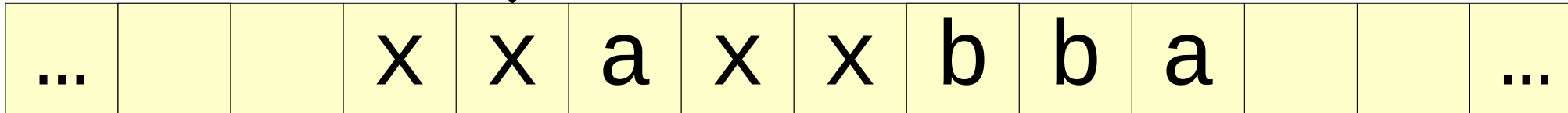
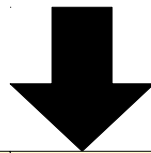

```
Start:  
  If 'a' Goto FoundA  
  Move Right  
  Goto Start
```

```
GoHome:  
  Move Left  
  If Not Blank Goto GoHome  
  Move Right  
  Goto Start
```

```
FoundA:  
  Write 'x'  
LoopA:  
  Move Right  
  If 'a' Goto LoopA  
  If 'x' Goto LoopA  
  Write 'x'  
  Goto GoHome
```

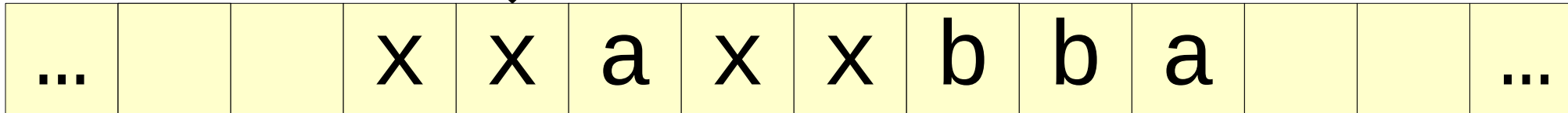
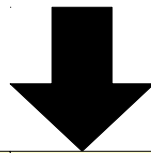

Start:

```
If 'a' Goto FoundA  
Move Right  
Goto Start
```

FoundA:

```
Write 'x'
```

LoopA:

```
Move Right
```

```
If 'a' Goto LoopA
```

```
If 'x' Goto LoopA
```

```
Write 'x'
```

```
Goto GoHome
```

GoHome:

```
Move Left
```

```
If Not Blank Goto GoHome
```

```
Move Right
```

```
Goto Start
```

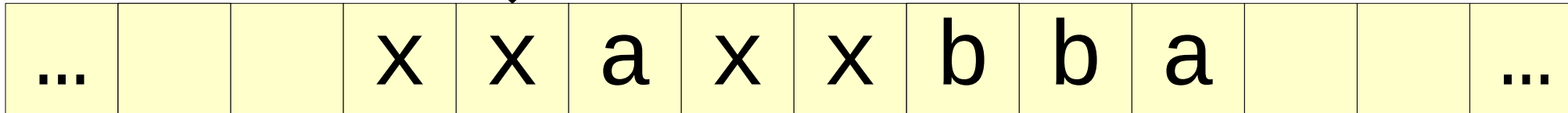
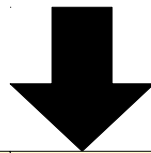

Start:

If 'a' Goto FoundA

Move Right

Goto Start

FoundA:

Write 'x'

LoopA:

Move Right

If 'a' Goto LoopA

If 'x' Goto LoopA

Write 'x'

Goto GoHome

GoHome:

Move Left

If Not Blank Goto GoHome

Move Right

Goto Start

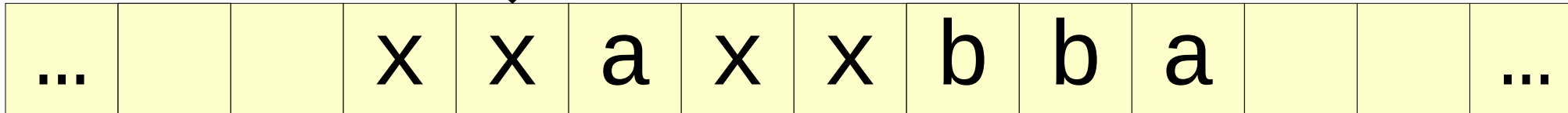
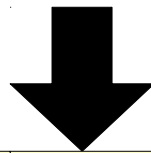

```
Start:  
  If 'a' Goto FoundA  
  Move Right  
  Goto Start
```

```
GoHome:  
  Move Left  
  If Not Blank Goto GoHome  
  Move Right  
  Goto Start
```

```
FoundA:  
  Write 'x'  
LoopA:  
  Move Right  
  If 'a' Goto LoopA  
  If 'x' Goto LoopA  
  Write 'x'  
  Goto GoHome
```

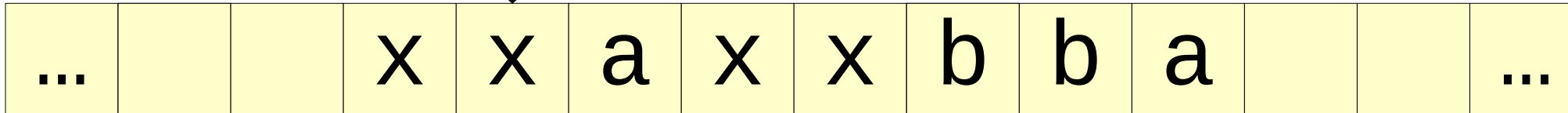
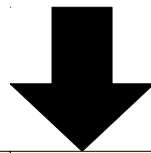

```
Start:  
  If 'a' Goto FoundA  
  Move Right  
  Goto Start
```

```
GoHome:  
  Move Left  
  If Not Blank Goto GoHome  
  Move Right  
  Goto Start
```

```
FoundA:  
  Write 'x'  
LoopA:  
  Move Right  
  If 'a' Goto LoopA  
  If 'x' Goto LoopA  
  Write 'x'  
  Goto GoHome
```

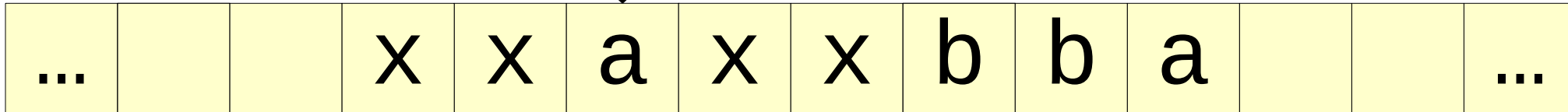
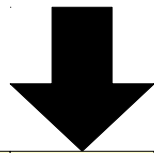

```
Start:  
  If 'a' Goto FoundA  
  Move Right  
  Goto Start
```

```
GoHome:  
  Move Left  
  If Not Blank Goto GoHome  
  Move Right  
  Goto Start
```

```
FoundA:  
  Write 'x'  
LoopA:  
  Move Right  
  If 'a' Goto LoopA  
  If 'x' Goto LoopA  
  Write 'x'  
  Goto GoHome
```

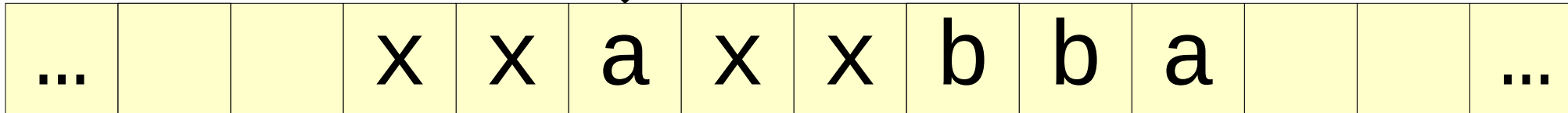
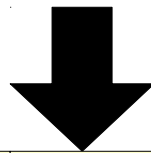

Start:

```
If 'a' Goto FoundA  
Move Right  
Goto Start
```

FoundA:

```
Write 'x'
```

LoopA:

```
Move Right  
If 'a' Goto LoopA  
If 'x' Goto LoopA  
Write 'x'  
Goto GoHome
```

GoHome:

```
Move Left  
If Not Blank Goto GoHome  
Move Right  
Goto Start
```

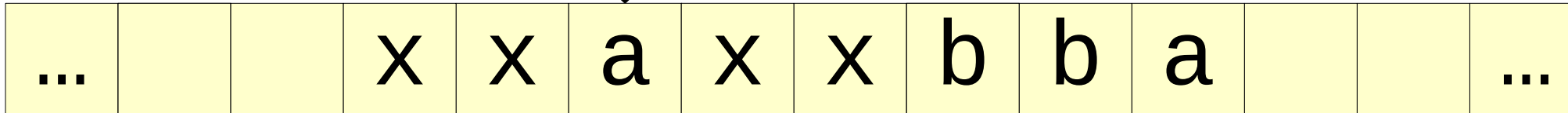
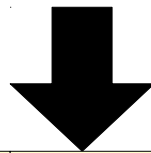

Start:

If 'a' Goto FoundA

Move Right

Goto Start

FoundA:

Write 'x'

LoopA:

Move Right

If 'a' Goto LoopA

If 'x' Goto LoopA

Write 'x'

Goto GoHome

GoHome:

Move Left

If Not Blank Goto GoHome

Move Right

Goto Start

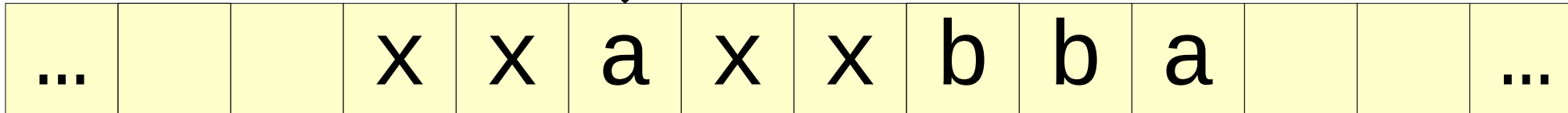
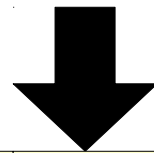

```
Start:  
  If 'a' Goto FoundA  
  Move Right  
  Goto Start
```

```
GoHome:  
  Move Left  
  If Not Blank Goto GoHome  
  Move Right  
  Goto Start
```

FoundA:

```
  Write 'x'  
LoopA:  
  Move Right  
  If 'a' Goto LoopA  
  If 'x' Goto LoopA  
  Write 'x'  
  Goto GoHome
```

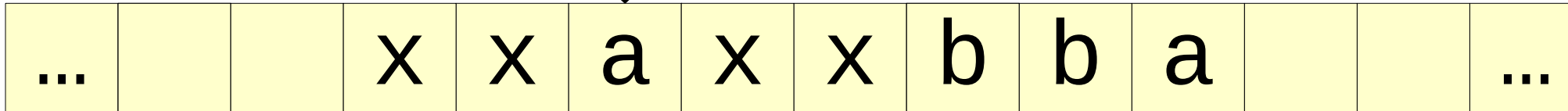
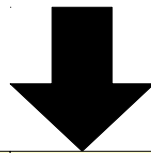

```
Start:  
  If 'a' Goto FoundA  
  Move Right  
  Goto Start
```

```
GoHome:  
  Move Left  
  If Not Blank Goto GoHome  
  Move Right  
  Goto Start
```

```
FoundA:
```

```
Write 'x'
```

```
LoopA:
```

```
  Move Right
```

```
  If 'a' Goto LoopA
```

```
  If 'x' Goto LoopA
```

```
  Write 'x'
```

```
  Goto GoHome
```

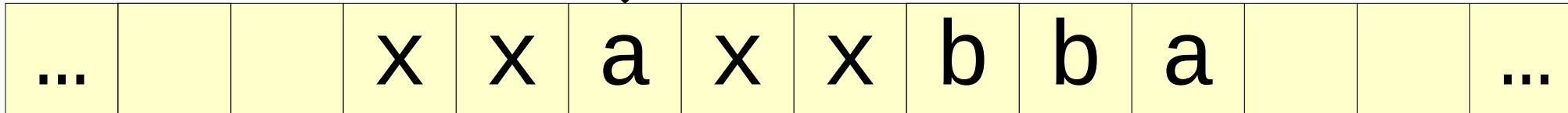
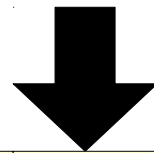

```
Start:  
  If 'a' Goto FoundA  
  Move Right  
  Goto Start
```

```
GoHome:  
  Move Left  
  If Not Blank Goto GoHome  
  Move Right  
  Goto Start
```

```
FoundA:
```

```
Write 'x'
```

```
LoopA:
```

```
  Move Right
```

```
  If 'a' Goto LoopA
```

```
  If 'x' Goto LoopA
```

```
  Write 'x'
```

```
  Goto GoHome
```

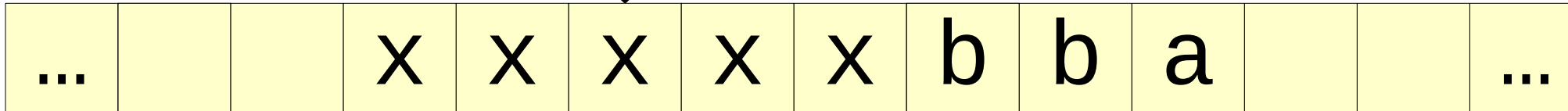
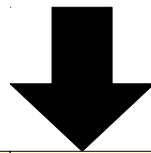

```
Start:  
  If 'a' Goto FoundA  
  Move Right  
  Goto Start
```

```
FoundA:  
  Write 'x'
```

```
LoopA:  
  Move Right  
  If 'a' Goto LoopA  
  If 'x' Goto LoopA  
  Write 'x'  
  Goto GoHome
```

```
GoHome:  
  Move Left  
  If Not Blank Goto GoHome  
  Move Right  
  Goto Start
```

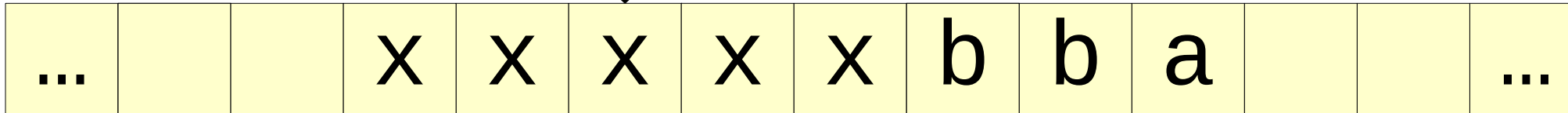
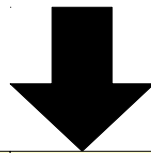

```
Start:  
  If 'a' Goto FoundA  
  Move Right  
  Goto Start
```

```
FoundA:  
  Write 'x'
```

```
LoopA:  
  Move Right  
  If 'a' Goto LoopA  
  If 'x' Goto LoopA  
  Write 'x'  
  Goto GoHome
```

```
GoHome:  
  Move Left  
  If Not Blank Goto GoHome  
  Move Right  
  Goto Start
```

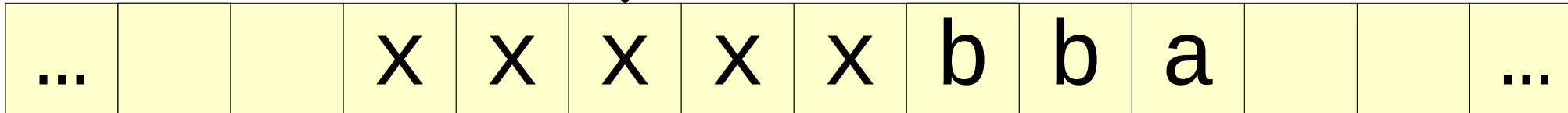
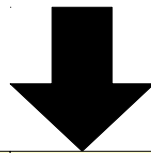

```
Start:  
  If 'a' Goto FoundA  
  Move Right  
  Goto Start
```

```
FoundA:  
  Write 'x'
```

```
LoopA:  
  Move Right  
  If 'a' Goto LoopA  
  If 'x' Goto LoopA  
  Write 'x'  
  Goto GoHome
```

```
GoHome:  
  Move Left  
  If Not Blank Goto GoHome  
  Move Right  
  Goto Start
```

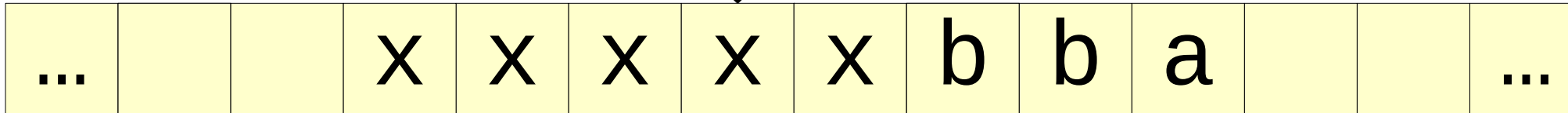
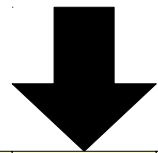

```
Start:  
  If 'a' Goto FoundA  
  Move Right  
  Goto Start
```

```
FoundA:  
  Write 'x'
```

```
LoopA:  
  Move Right  
  If 'a' Goto LoopA  
  If 'x' Goto LoopA  
  Write 'x'  
  Goto GoHome
```

```
GoHome:  
  Move Left  
  If Not Blank Goto GoHome  
  Move Right  
  Goto Start
```

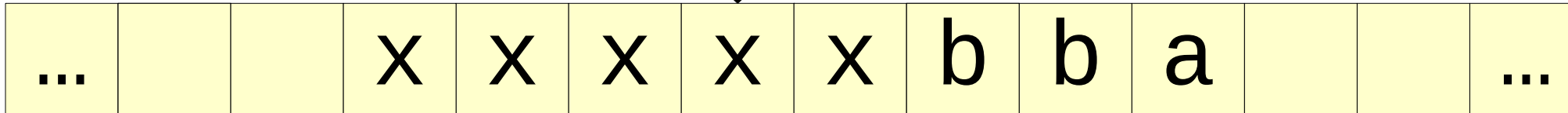
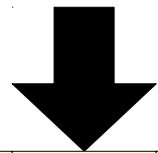

```
Start:  
  If 'a' Goto FoundA  
  Move Right  
  Goto Start
```

```
FoundA:  
  Write 'x'
```

```
LoopA:  
  Move Right  
  If 'a' Goto LoopA  
  If 'x' Goto LoopA  
  Write 'x'  
  Goto GoHome
```

```
GoHome:  
  Move Left  
  If Not Blank Goto GoHome  
  Move Right  
  Goto Start
```

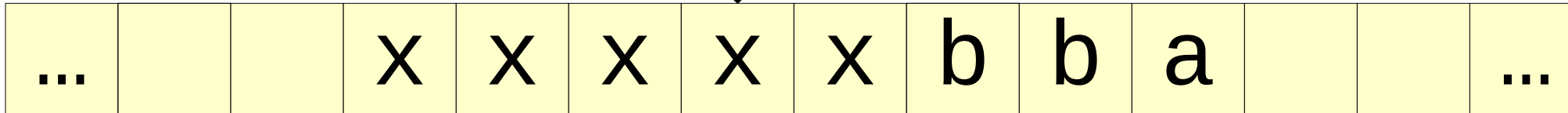
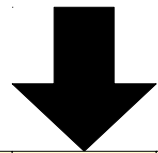

```
Start:  
  If 'a' Goto FoundA  
  Move Right  
  Goto Start
```

```
FoundA:  
  Write 'x'
```

```
LoopA:  
  Move Right  
  If 'a' Goto LoopA  
  If 'x' Goto LoopA  
  Write 'x'  
  Goto GoHome
```

```
GoHome:  
  Move Left  
  If Not Blank Goto GoHome  
  Move Right  
  Goto Start
```

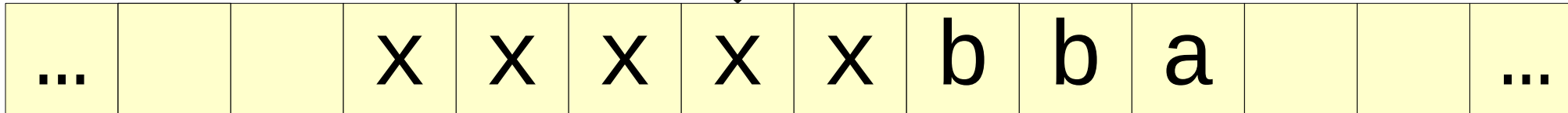
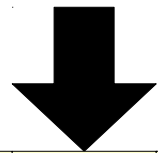

```
Start:  
  If 'a' Goto FoundA  
  Move Right  
  Goto Start
```

```
FoundA:  
  Write 'x'
```

```
LoopA:  
  Move Right  
  If 'a' Goto LoopA  
  If 'x' Goto LoopA  
  Write 'x'  
  Goto GoHome
```

```
GoHome:  
  Move Left  
  If Not Blank Goto GoHome  
  Move Right  
  Goto Start
```

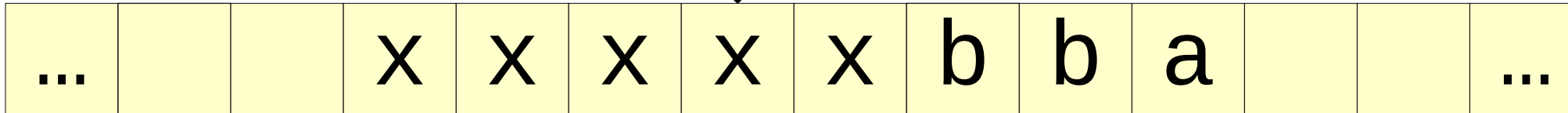
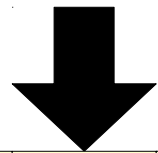

```
Start:  
  If 'a' Goto FoundA  
  Move Right  
  Goto Start
```

```
FoundA:  
  Write 'x'
```

```
LoopA:  
  Move Right  
  If 'a' Goto LoopA  
  If 'x' Goto LoopA  
  Write 'x'  
  Goto GoHome
```

```
GoHome:  
  Move Left  
  If Not Blank Goto GoHome  
  Move Right  
  Goto Start
```

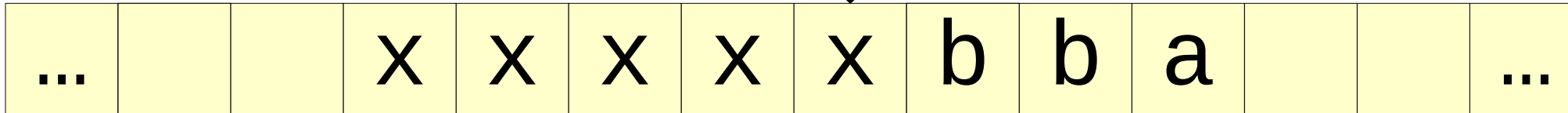
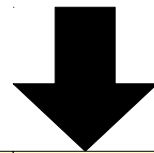

```
Start:  
  If 'a' Goto FoundA  
  Move Right  
  Goto Start
```

```
FoundA:  
  Write 'x'
```

```
LoopA:  
  Move Right  
  If 'a' Goto LoopA  
  If 'x' Goto LoopA  
  Write 'x'  
  Goto GoHome
```

```
GoHome:  
  Move Left  
  If Not Blank Goto GoHome  
  Move Right  
  Goto Start
```

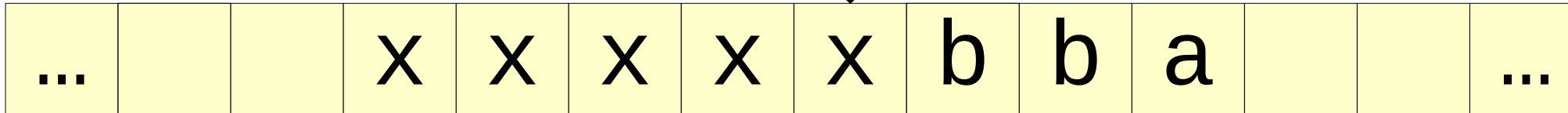
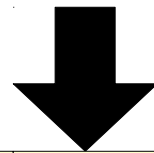

```
Start:  
  If 'a' Goto FoundA  
  Move Right  
  Goto Start
```

```
FoundA:  
  Write 'x'
```

```
LoopA:  
  Move Right  
  If 'a' Goto LoopA  
  If 'x' Goto LoopA  
  Write 'x'  
  Goto GoHome
```

```
GoHome:  
  Move Left  
  If Not Blank Goto GoHome  
  Move Right  
  Goto Start
```

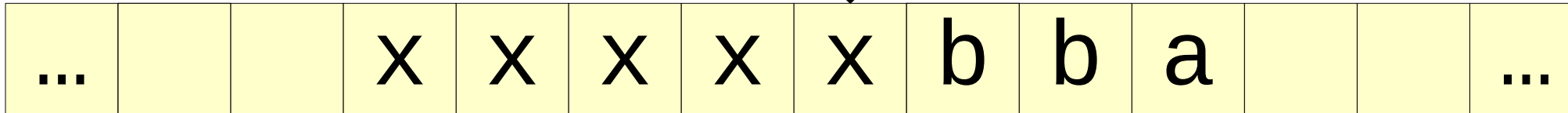
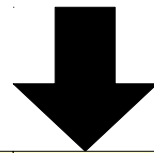

```
Start:  
  If 'a' Goto FoundA  
  Move Right  
  Goto Start
```

```
FoundA:  
  Write 'x'
```

```
LoopA:  
  Move Right  
  If 'a' Goto LoopA  
  If 'x' Goto LoopA  
  Write 'x'  
  Goto GoHome
```

```
GoHome:  
  Move Left  
  If Not Blank Goto GoHome  
  Move Right  
  Goto Start
```

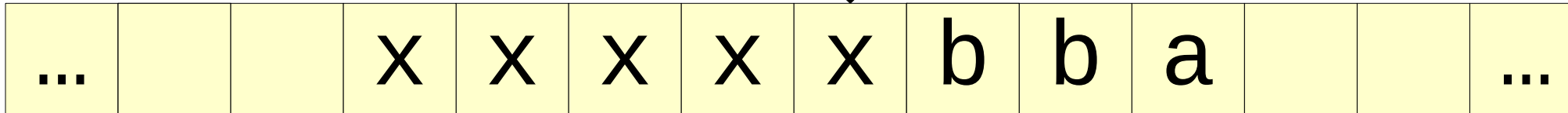
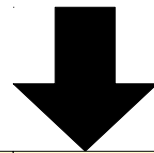

```
Start:  
  If 'a' Goto FoundA  
  Move Right  
  Goto Start
```

```
FoundA:  
  Write 'x'
```

```
LoopA:  
  Move Right  
  If 'a' Goto LoopA  
  If 'x' Goto LoopA  
  Write 'x'  
  Goto GoHome
```

```
GoHome:  
  Move Left  
  If Not Blank Goto GoHome  
  Move Right  
  Goto Start
```

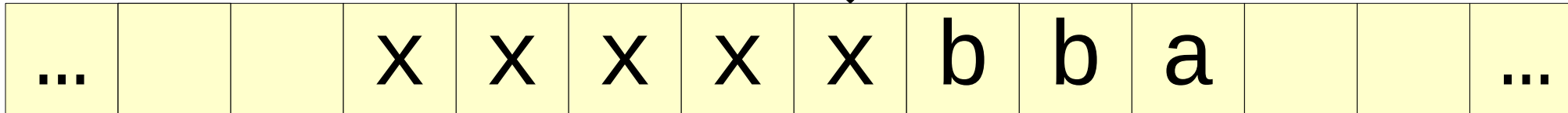
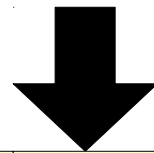

```
Start:  
  If 'a' Goto FoundA  
  Move Right  
  Goto Start
```

```
FoundA:  
  Write 'x'
```

```
LoopA:  
  Move Right  
  If 'a' Goto LoopA  
  If 'x' Goto LoopA  
  Write 'x'  
  Goto GoHome
```

```
GoHome:  
  Move Left  
  If Not Blank Goto GoHome  
  Move Right  
  Goto Start
```

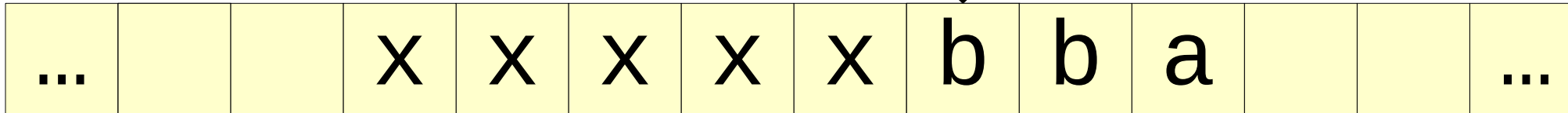
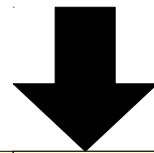

```
Start:  
  If 'a' Goto FoundA  
  Move Right  
  Goto Start
```

```
FoundA:  
  Write 'x'
```

```
LoopA:  
  Move Right  
  If 'a' Goto LoopA  
  If 'x' Goto LoopA  
  Write 'x'  
  Goto GoHome
```

```
GoHome:  
  Move Left  
  If Not Blank Goto GoHome  
  Move Right  
  Goto Start
```

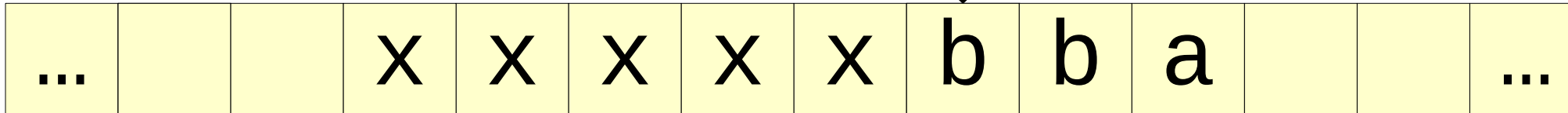
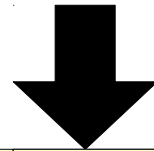

```
Start:  
  If 'a' Goto FoundA  
  Move Right  
  Goto Start
```

```
FoundA:  
  Write 'x'
```

```
LoopA:  
  Move Right  
  If 'a' Goto LoopA  
  If 'x' Goto LoopA  
  Write 'x'  
  Goto GoHome
```

```
GoHome:  
  Move Left  
  If Not Blank Goto GoHome  
  Move Right  
  Goto Start
```

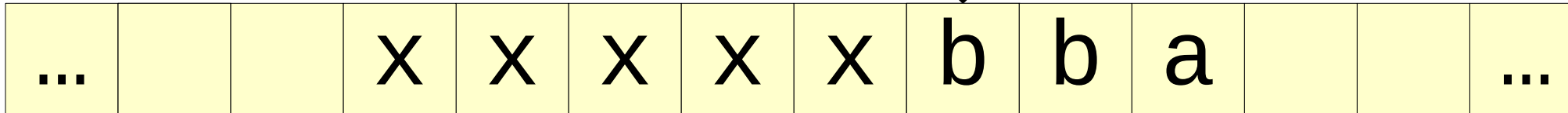
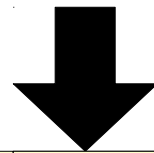

```
Start:  
  If 'a' Goto FoundA  
  Move Right  
  Goto Start
```

```
FoundA:  
  Write 'x'
```

```
LoopA:  
  Move Right  
  If 'a' Goto LoopA  
  If 'x' Goto LoopA  
  Write 'x'  
  Goto GoHome
```

```
GoHome:  
  Move Left  
  If Not Blank Goto GoHome  
  Move Right  
  Goto Start
```

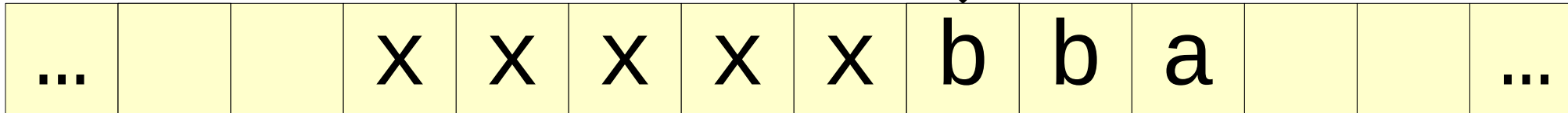
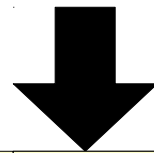

```
Start:  
  If 'a' Goto FoundA  
  Move Right  
  Goto Start
```

```
FoundA:  
  Write 'x'
```

```
LoopA:  
  Move Right  
  If 'a' Goto LoopA  
  If 'x' Goto LoopA  
  Write 'x'  
  Goto GoHome
```

```
GoHome:  
  Move Left  
  If Not Blank Goto GoHome  
  Move Right  
  Goto Start
```

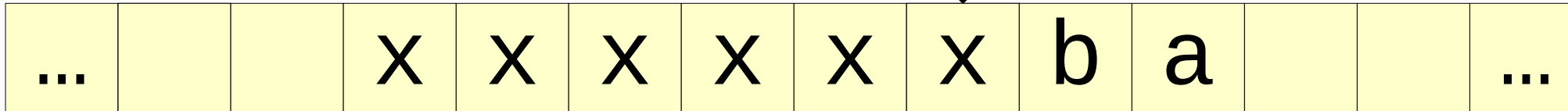
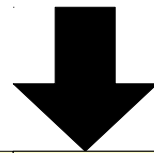

```
Start:  
  If 'a' Goto FoundA  
  Move Right  
  Goto Start
```

```
FoundA:  
  Write 'x'
```

```
LoopA:  
  Move Right  
  If 'a' Goto LoopA  
  If 'x' Goto LoopA  
  Write 'x'  
  Goto GoHome
```

```
GoHome:  
  Move Left  
  If Not Blank Goto GoHome  
  Move Right  
  Goto Start
```

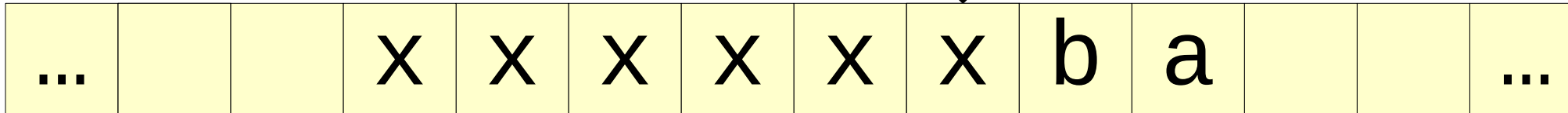
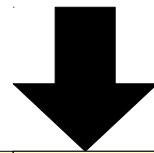

```
Start:  
  If 'a' Goto FoundA  
  Move Right  
  Goto Start
```

```
FoundA:  
  Write 'x'
```

```
LoopA:  
  Move Right  
  If 'a' Goto LoopA  
  If 'x' Goto LoopA  
  Write 'x'  
  Goto GoHome
```

```
GoHome:  
  Move Left  
  If Not Blank Goto GoHome  
  Move Right  
  Goto Start
```

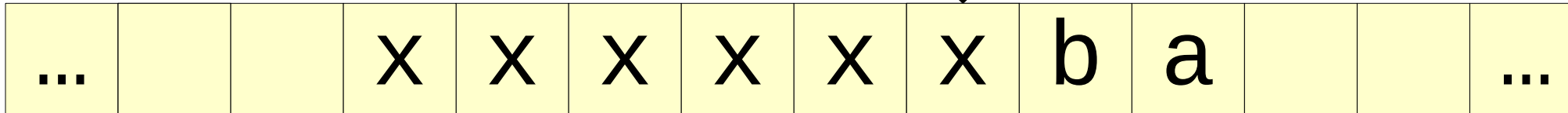
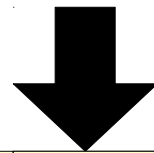

```
Start:  
  If 'a' Goto FoundA  
  Move Right  
  Goto Start
```

```
FoundA:  
  Write 'x'
```

```
LoopA:  
  Move Right  
  If 'a' Goto LoopA  
  If 'x' Goto LoopA  
  Write 'x'  
  Goto GoHome
```

```
GoHome:  
  Move Left  
  If Not Blank Goto GoHome  
  Move Right  
  Goto Start
```

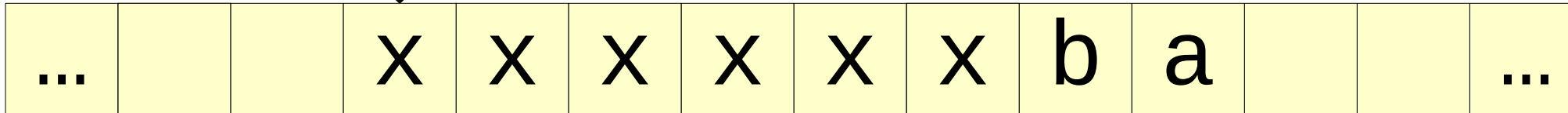
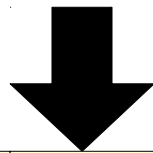

Start:

```
If 'a' Goto FoundA  
Move Right  
Goto Start
```

FoundA:

```
Write 'x'
```

LoopA:

```
Move Right  
If 'a' Goto LoopA  
If 'x' Goto LoopA  
Write 'x'  
Goto GoHome
```

GoHome:

```
Move Left  
If Not Blank Goto GoHome  
Move Right  
Goto Start
```

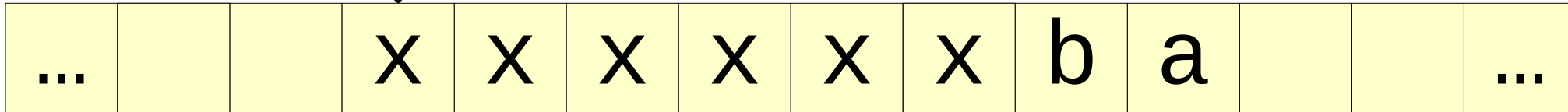
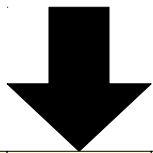

Start:

If 'a' Goto FoundA

Move Right

Goto Start

FoundA:

Write 'x'

LoopA:

Move Right

If 'a' Goto LoopA

If 'x' Goto LoopA

Write 'x'

Goto GoHome

GoHome:

Move Left

If Not Blank Goto GoHome

Move Right

Goto Start

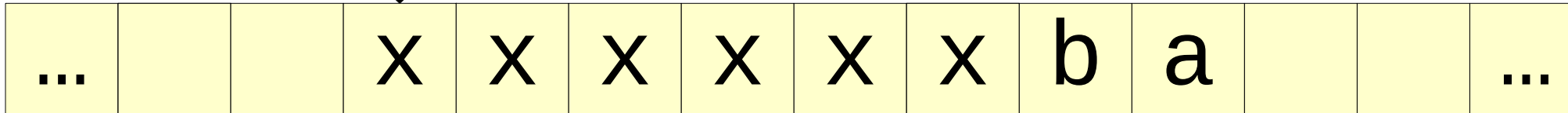
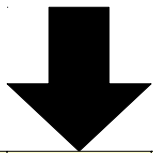

```
Start:  
  If 'a' Goto FoundA  
  Move Right  
  Goto Start
```

```
GoHome:  
  Move Left  
  If Not Blank Goto GoHome  
  Move Right  
  Goto Start
```

```
FoundA:  
  Write 'x'  
LoopA:  
  Move Right  
  If 'a' Goto LoopA  
  If 'x' Goto LoopA  
  Write 'x'  
  Goto GoHome
```

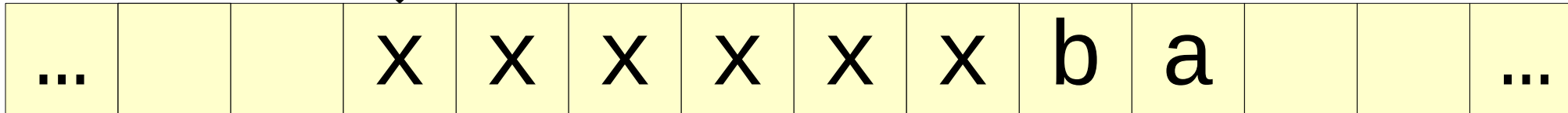
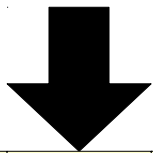

```
Start:  
  If 'a' Goto FoundA  
  Move Right  
  Goto Start
```

```
GoHome:  
  Move Left  
  If Not Blank Goto GoHome  
  Move Right  
  Goto Start
```

```
FoundA:  
  Write 'x'  
LoopA:  
  Move Right  
  If 'a' Goto LoopA  
  If 'x' Goto LoopA  
  Write 'x'  
  Goto GoHome
```

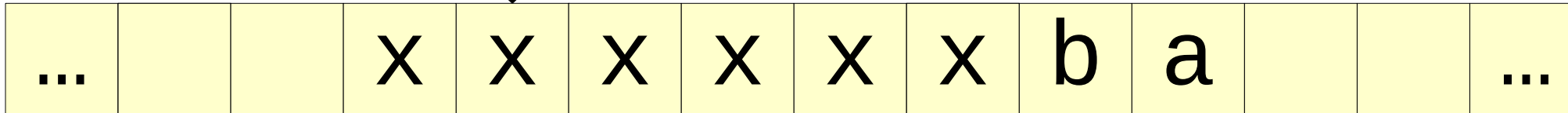
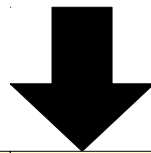

```
Start:  
  If 'a' Goto FoundA  
  Move Right  
  Goto Start
```

```
GoHome:  
  Move Left  
  If Not Blank Goto GoHome  
  Move Right  
  Goto Start
```

```
FoundA:  
  Write 'x'  
LoopA:  
  Move Right  
  If 'a' Goto LoopA  
  If 'x' Goto LoopA  
  Write 'x'  
  Goto GoHome
```

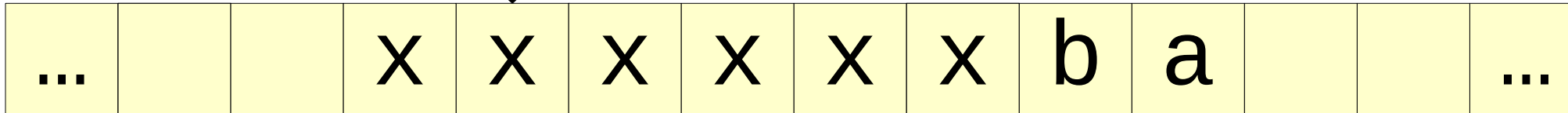
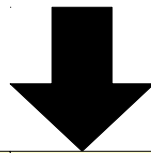

```
Start:  
  If 'a' Goto FoundA  
  Move Right  
  Goto Start
```

```
GoHome:  
  Move Left  
  If Not Blank Goto GoHome  
  Move Right  
  Goto Start
```

```
FoundA:  
  Write 'x'  
LoopA:  
  Move Right  
  If 'a' Goto LoopA  
  If 'x' Goto LoopA  
  Write 'x'  
  Goto GoHome
```

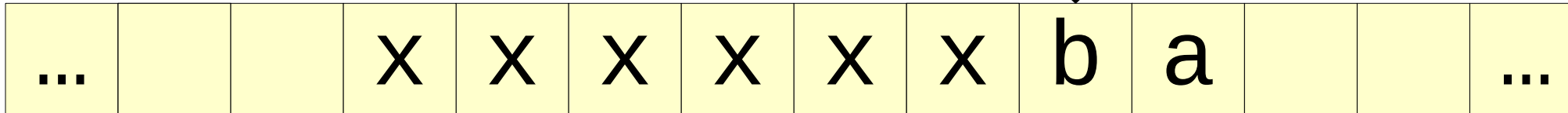
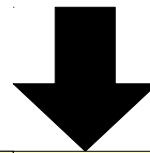

Start:

```
If 'a' Goto FoundA  
Move Right  
Goto Start
```

FoundA:

```
Write 'x'
```

LoopA:

```
Move Right
```

```
If 'a' Goto LoopA
```

```
If 'x' Goto LoopA
```

```
Write 'x'
```

```
Goto GoHome
```

GoHome:

```
Move Left
```

```
If Not Blank Goto GoHome
```

```
Move Right
```

```
Goto Start
```

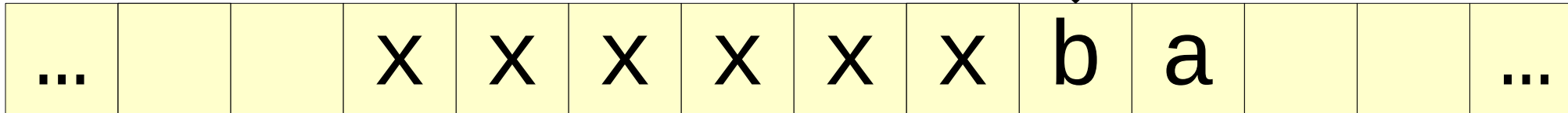
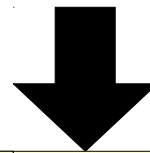

Start:

If 'a' Goto FoundA

Move Right

Goto Start

FoundA:

Write 'x'

LoopA:

Move Right

If 'a' Goto LoopA

If 'x' Goto LoopA

Write 'x'

Goto GoHome

GoHome:

Move Left

If Not Blank Goto GoHome

Move Right

Goto Start

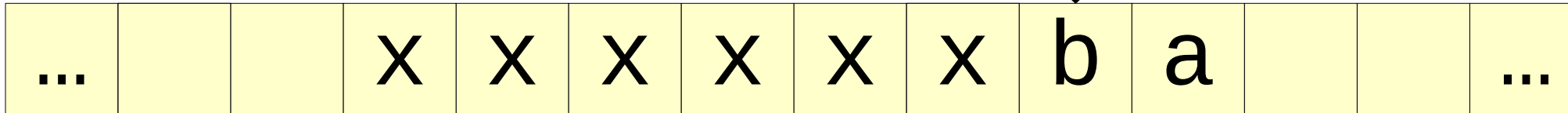
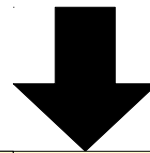

Start:

If 'a' Goto FoundA

Move Right
Goto Start

FoundA:

Write 'x'

LoopA:

Move Right

If 'a' Goto LoopA

If 'x' Goto LoopA

Write 'x'

Goto GoHome

GoHome:

Move Left

If Not Blank Goto GoHome

Move Right

Goto Start

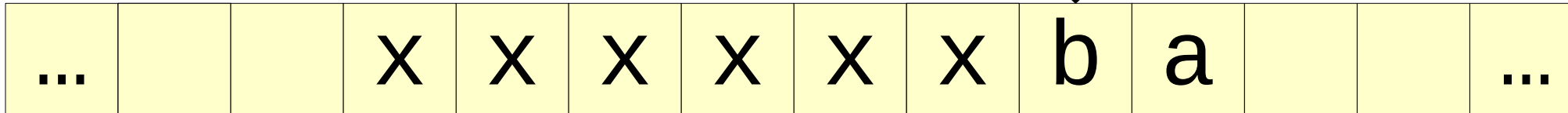
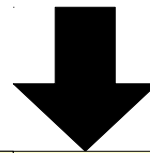

```
Start:  
  If 'a' Goto FoundA  
  Move Right  
  Goto Start
```

```
FoundA:  
  Write 'x'  
LoopA:  
  Move Right  
  If 'a' Goto LoopA  
  If 'x' Goto LoopA  
  Write 'x'  
  Goto GoHome
```

```
GoHome:  
  Move Left  
  If Not Blank Goto GoHome  
  Move Right  
  Goto Start
```

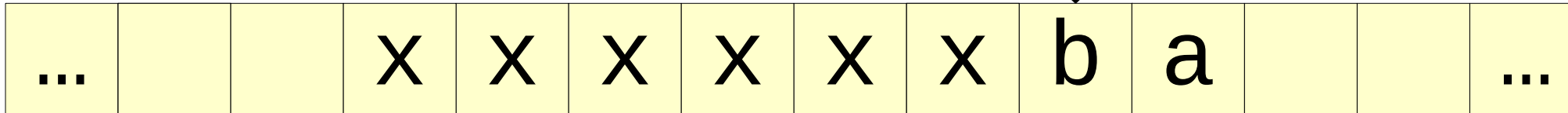
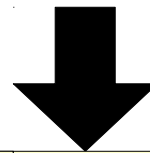

```
Start:  
  If 'a' Goto FoundA  
  If 'b' Goto FoundB  
  Move Right  
  Goto Start
```

```
GoHome:  
  Move Left  
  If Not Blank Goto GoHome  
  Move Right  
  Goto Start
```

```
FoundA:  
  Write 'x'  
LoopA:  
  Move Right  
  If 'a' Goto LoopA  
  If 'x' Goto LoopA  
  Write 'x'  
  Goto GoHome
```

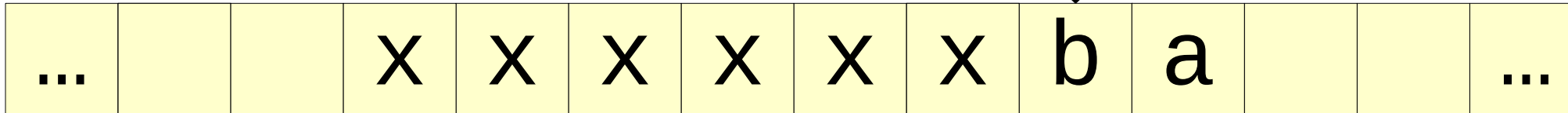
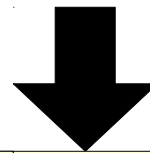

```
Start:  
  If 'a' Goto FoundA  
  If 'b' Goto FoundB  
  Move Right  
  Goto Start
```

```
FoundA:  
  Write 'x'  
LoopA:  
  Move Right  
  If 'a' Goto LoopA  
  If 'x' Goto LoopA  
  Write 'x'  
  Goto GoHome
```

```
GoHome:  
  Move Left  
  If Not Blank Goto GoHome  
  Move Right  
  Goto Start
```

```
FoundB:  
  Write 'x'  
LoopB:  
  Move Right  
  If 'b' Goto LoopB  
  If 'x' Goto LoopB  
  Write 'x'  
  Goto GoHome
```

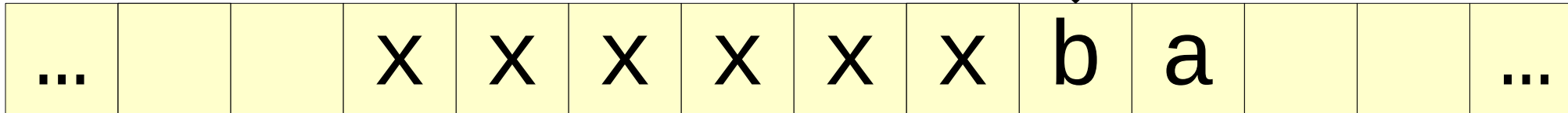
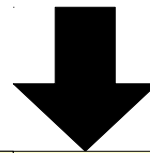

```
Start:
  If 'a' Goto FoundA
  If 'b' Goto FoundB
  Move Right
  Goto Start
```

```
FoundA:
  Write 'x'
LoopA:
  Move Right
  If 'a' Goto LoopA
  If 'x' Goto LoopA
  Write 'x'
  Goto GoHome
```

```
GoHome:
  Move Left
  If Not Blank Goto GoHome
  Move Right
  Goto Start
```

```
FoundB:
  Write 'x'
LoopB:
  Move Right
  If 'b' Goto LoopB
  If 'x' Goto LoopB
  Write 'x'
  Goto GoHome
```

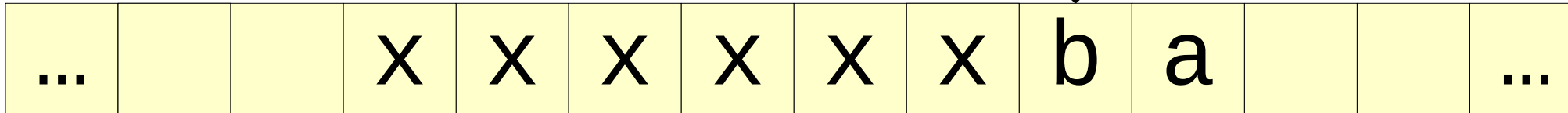
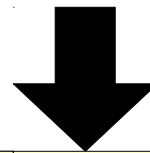

```
Start:
  If 'a' Goto FoundA
  If 'b' Goto FoundB
  Move Right
  Goto Start
```

```
FoundA:
  Write 'x'
LoopA:
  Move Right
  If 'a' Goto LoopA
  If 'x' Goto LoopA
  Write 'x'
  Goto GoHome
```

```
GoHome:
  Move Left
  If Not Blank Goto GoHome
  Move Right
  Goto Start
```

```
FoundB:
  Write 'x'
LoopB:
  Move Right
  If 'b' Goto LoopB
  If 'x' Goto LoopB
  Write 'x'
  Goto GoHome
```

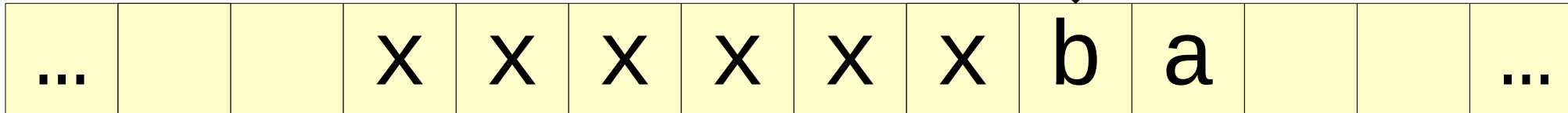
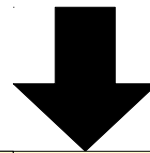

```
Start:
  If 'a' Goto FoundA
  If 'b' Goto FoundB
  Move Right
  Goto Start
```

```
FoundA:
  Write 'x'
LoopA:
  Move Right
  If 'a' Goto LoopA
  If 'x' Goto LoopA
  Write 'x'
  Goto GoHome
```

```
GoHome:
  Move Left
  If Not Blank Goto GoHome
  Move Right
  Goto Start
```

```
FoundB:
  Write 'x'
LoopB:
  Move Right
  If 'b' Goto LoopB
  If 'x' Goto LoopB
  Write 'x'
  Goto GoHome
```

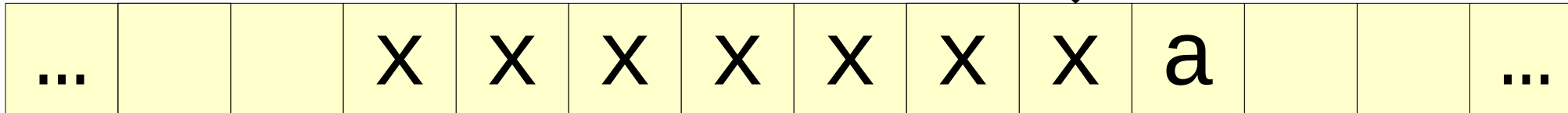
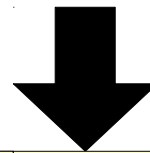

```
Start:
  If 'a' Goto FoundA
  If 'b' Goto FoundB
  Move Right
  Goto Start
```

```
FoundA:
  Write 'x'
LoopA:
  Move Right
  If 'a' Goto LoopA
  If 'x' Goto LoopA
  Write 'x'
  Goto GoHome
```

```
GoHome:
  Move Left
  If Not Blank Goto GoHome
  Move Right
  Goto Start
```

```
FoundB:
  Write 'x'
LoopB:
  Move Right
  If 'b' Goto LoopB
  If 'x' Goto LoopB
  Write 'x'
  Goto GoHome
```

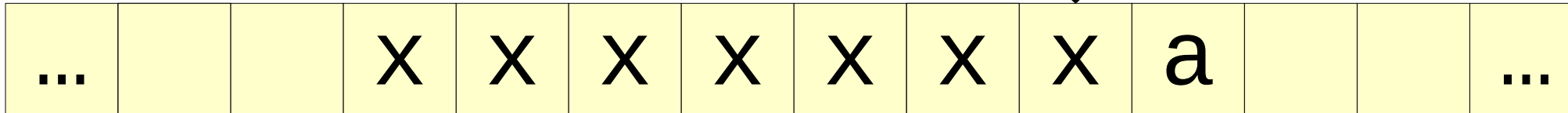
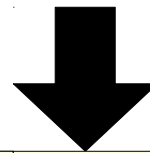

```
Start:
  If 'a' Goto FoundA
  If 'b' Goto FoundB
  Move Right
  Goto Start
```

```
FoundA:
  Write 'x'
LoopA:
  Move Right
  If 'a' Goto LoopA
  If 'x' Goto LoopA
  Write 'x'
  Goto GoHome
```

```
GoHome:
  Move Left
  If Not Blank Goto GoHome
  Move Right
  Goto Start
```

```
FoundB:
  Write 'x'
LoopB:
  Move Right
  If 'b' Goto LoopB
  If 'x' Goto LoopB
  Write 'x'
  Goto GoHome
```

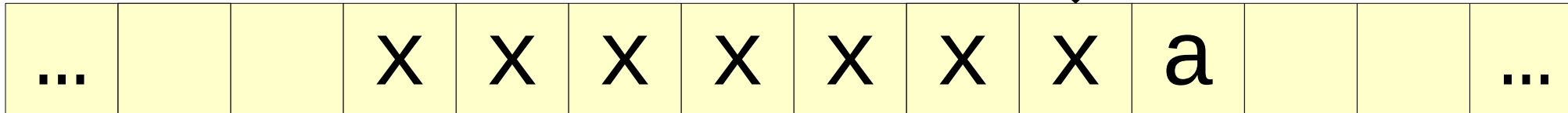
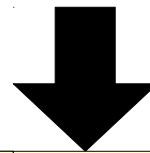

```
Start:
  If 'a' Goto FoundA
  If 'b' Goto FoundB
  Move Right
  Goto Start
```

```
FoundA:
  Write 'x'
LoopA:
  Move Right
  If 'a' Goto LoopA
  If 'x' Goto LoopA
  Write 'x'
  Goto GoHome
```

```
GoHome:
  Move Left
  If Not Blank Goto GoHome
  Move Right
  Goto Start
```

```
FoundB:
  Write 'x'
LoopB:
  Move Right
  If 'b' Goto LoopB
  If 'x' Goto LoopB
  Write 'x'
  Goto GoHome
```

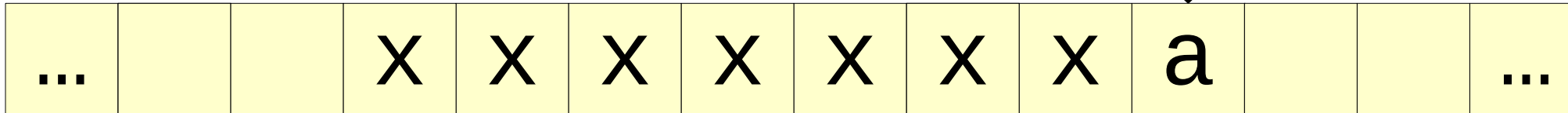
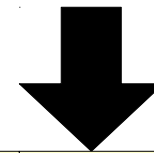

```
Start:
  If 'a' Goto FoundA
  If 'b' Goto FoundB
  Move Right
  Goto Start
```

```
FoundA:
  Write 'x'
LoopA:
  Move Right
  If 'a' Goto LoopA
  If 'x' Goto LoopA
  Write 'x'
  Goto GoHome
```

```
GoHome:
  Move Left
  If Not Blank Goto GoHome
  Move Right
  Goto Start
```

```
FoundB:
  Write 'x'
LoopB:
  Move Right
  If 'b' Goto LoopB
  If 'x' Goto LoopB
  Write 'x'
  Goto GoHome
```

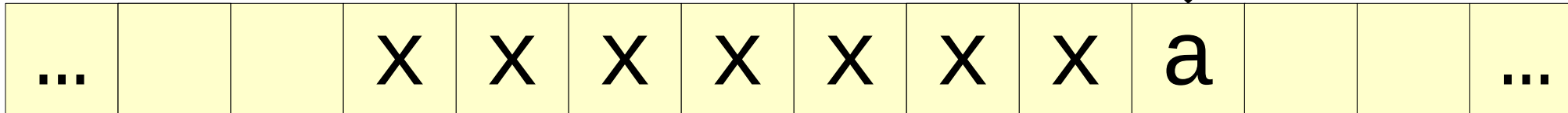
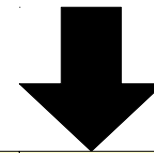

```
Start:
  If 'a' Goto FoundA
  If 'b' Goto FoundB
  Move Right
  Goto Start
```

```
FoundA:
  Write 'x'
LoopA:
  Move Right
  If 'a' Goto LoopA
  If 'x' Goto LoopA
  Write 'x'
  Goto GoHome
```

```
GoHome:
  Move Left
  If Not Blank Goto GoHome
  Move Right
  Goto Start
```

```
FoundB:
  Write 'x'
LoopB:
  Move Right
  If 'b' Goto LoopB
  If 'x' Goto LoopB
  Write 'x'
  Goto GoHome
```

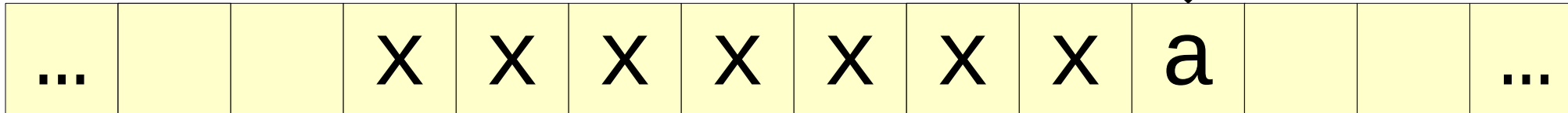
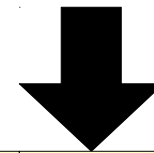

```
Start:  
  If 'a' Goto FoundA  
  If 'b' Goto FoundB  
  Move Right  
  Goto Start
```

```
FoundA:  
  Write 'x'  
LoopA:  
  Move Right  
  If 'a' Goto LoopA  
  If 'x' Goto LoopA  
  Write 'x'  
  Goto GoHome
```

```
GoHome:  
  Move Left  
  If Not Blank Goto GoHome  
  Move Right  
  Goto Start
```

```
FoundB:  
  Write 'x'  
LoopB:  
  Move Right  
  If 'b' Goto LoopB  
  If 'x' Goto LoopB  
  Write 'x'  
  Goto GoHome
```

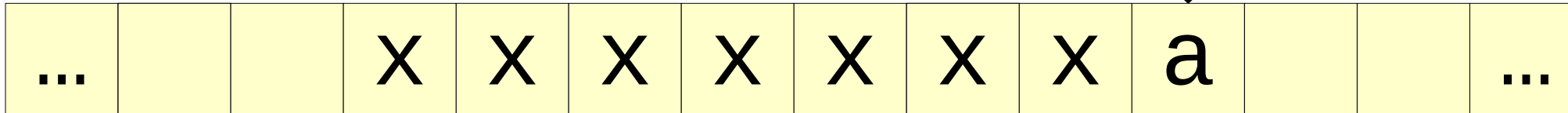
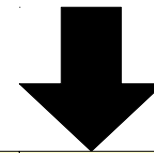



```
Start:
  If 'a' Goto FoundA
  If 'b' Goto FoundB
  Move Right
  Goto Start
```

```
FoundA:
  Write 'x'
LoopA:
  Move Right
  If 'a' Goto LoopA
  If 'x' Goto LoopA
  Write 'x'
  Goto GoHome
```

```
GoHome:
  Move Left
  If Not Blank Goto GoHome
  Move Right
  Goto Start
```

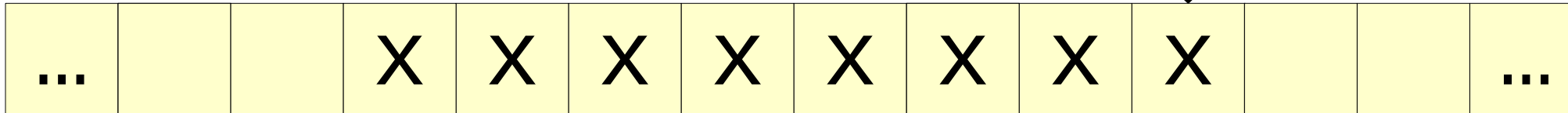
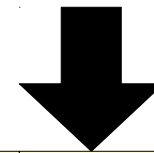
```
FoundB:
  Write 'x'
LoopB:
  Move Right
  If 'b' Goto LoopB
  If 'x' Goto LoopB
  Write 'x'
  Goto GoHome
```





```
Start:  
  If 'a' Goto FoundA  
  If 'b' Goto FoundB  
  Move Right  
  Goto Start
```

```
FoundA:  
  Write 'x'  
LoopA:  
  Move Right  
  If 'a' Goto LoopA  
  If 'x' Goto LoopA  
  Write 'x'  
  Goto GoHome
```

```
GoHome:  
  Move Left  
  If Not Blank Goto GoHome  
  Move Right  
  Goto Start
```

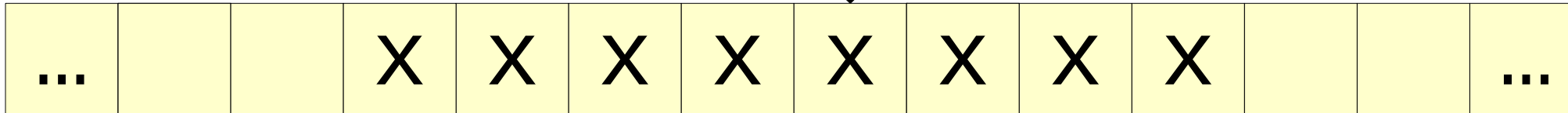
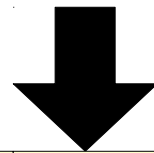
```
FoundB:  
  Write 'x'  
LoopB:  
  Move Right  
  If 'b' Goto LoopB  
  If 'x' Goto LoopB  
  Write 'x'  
  Goto GoHome
```



```
Start:
  If 'a' Goto FoundA
  If 'b' Goto FoundB
  If Blank Return True
  Move Right
  Goto Start
```

```
FoundA:
  Write 'x'
LoopA:
  Move Right
  If 'a' Goto LoopA
  If 'x' Goto LoopA
  Write 'x'
  Goto GoHome
```

```
GoHome:
  Move Left
  If Not Blank Goto GoHome
  Move Right
  Goto Start
```

```
FoundB:
  Write 'x'
LoopB:
  Move Right
  If 'b' Goto LoopB
  If 'x' Goto LoopB
  Write 'x'
  Goto GoHome
```



Another Idea

- We just built a TM for the language

$\{ w \in \{ \mathbf{a}, \mathbf{b} \}^* \mid w \text{ has the same number of } \mathbf{a}'\text{s and } \mathbf{b}'\text{s} \}$.

- An observation: this would be a *lot* easier to test for if all the **a**'s came before all the **b**'s.
 - In fact, that would turn this into checking if the string has the form $\mathbf{a}^n \mathbf{b}^n$, which we already know how to do!
- **Idea:** Could we sort the characters of our input string?

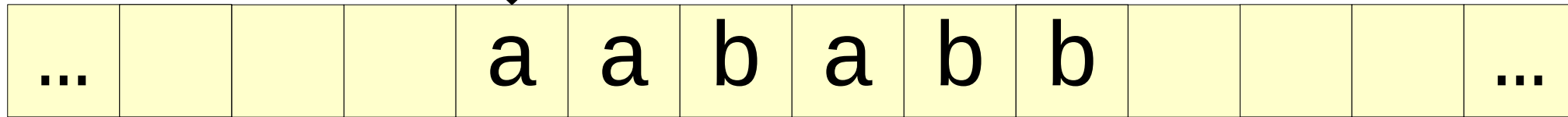
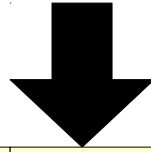
The Idea



The Idea

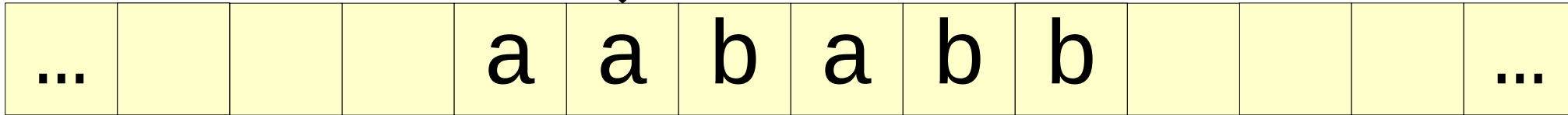
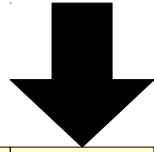

The Idea

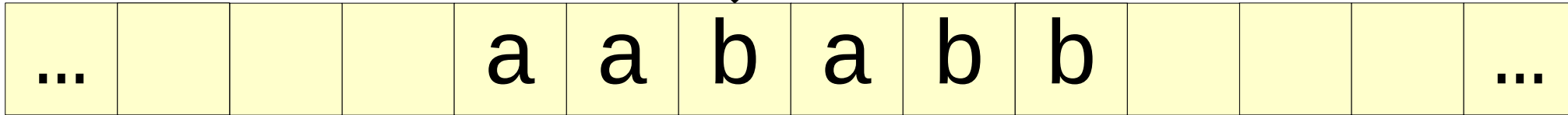
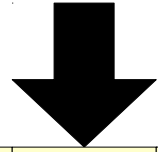

The Idea

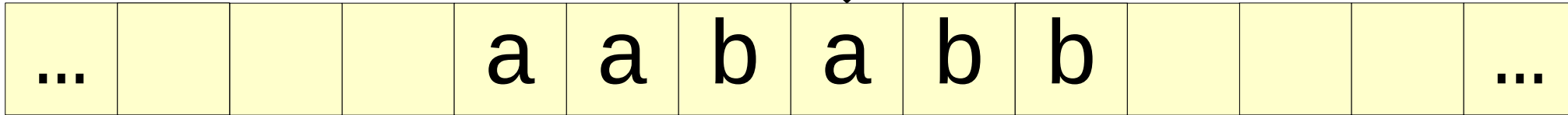
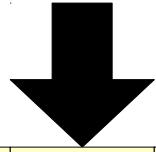

The Idea

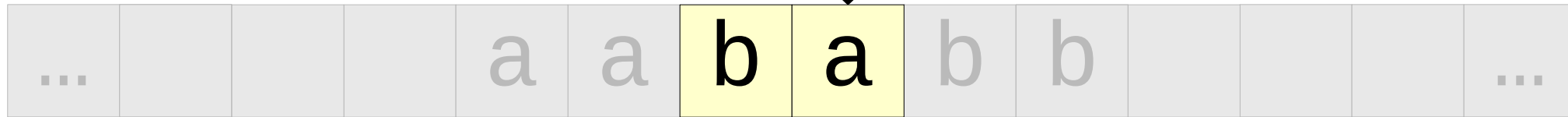
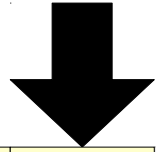

The Idea

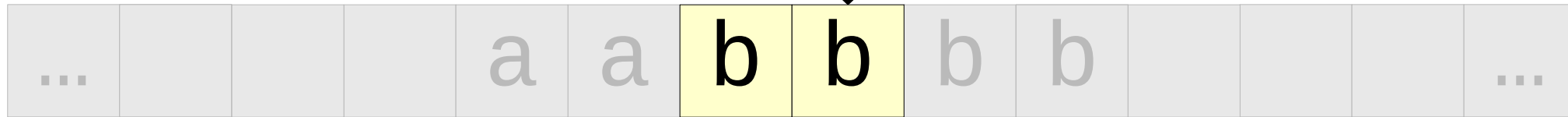
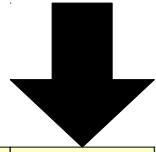

The Idea

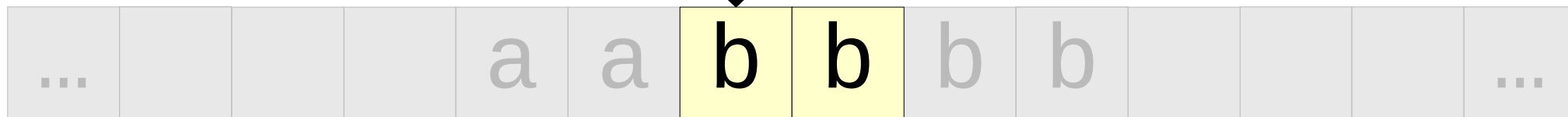
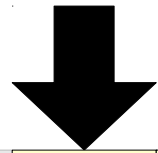

The Idea

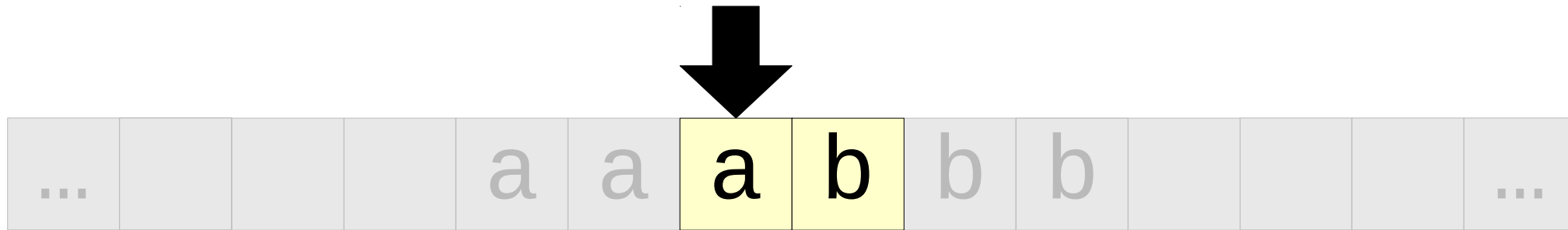

The Idea

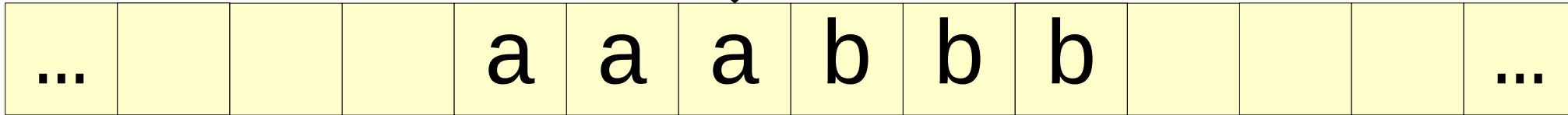
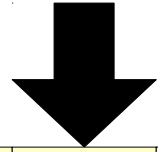

Key Idea: Abstraction

(in the form of Helper Functions)

- Once we have a Turing Machine that does one task, we can use it much like a helper function call for more complex Turing Machines
- This idea will prove key to the power and versatility of TMs.
- We will explore this idea more in coming days!

Next Time

- ***The Church-Turing Thesis***
 - How powerful are Turing machines?
- ***Decidability and Recognizability***
 - Two notions of “solving a problem.”